

**Model RT4-LP**  
**Loop Powered Indicator**  
**Operation and Instruction Manual**



---

## Table of Contents

---

<b>Introduction</b> . . . . .	<b>3</b>
<b>Mechanical Installation</b> . . . . .	<b>4</b>
<b>Electrical Installation</b> . . . . .	<b>5</b>
<b>Explanation of Functions</b> . . . . .	<b>6</b>
Set up functions. . . . .	7
Calibration functions . . . . .	8
Returning to the normal measure Mode . . . . .	9
<b>Function Table</b> . . . . .	<b>10</b>
<b>Examples and Trouble Shooting</b> . . . . .	<b>11</b>
Examples . . . . .	11
Trouble shooting . . . . .	12
<b>Specifications</b> . . . . .	<b>13</b>
<b>Guarantee and Service</b> . . . . .	<b>14</b>

---

# 1 Introduction

---

This manual contains information on the operation of the RT4-LP Intelligent Digital Loop Powered Indicator. Features of the RT4-LP are as follows:

- 2 Wire, 4-20mA or 10-50mA Loop Powered (programmable selection).
- Full 4 digit, High Contrast 12.7mm LCD Display  
or 4.5 digit, High Contrast 10.2mm LCD Display
- Display Is Fully Scaleable To Read In Process Units
- All Scaling And Set Up Is Via Push Buttons
- On Display “prompts” Help To Make Setup Simple
- Can Be Calibrated Without Tools Or Test Equipment
- Inbuilt Square Root Extractor
- Programmable Digital Filter To Reduce Susceptibility to Noise
- Remote Input To Perform Functions Such As Maximum, Minimum, Peak, Display Hold

Unless otherwise specified at the time of order, your RT4 has been factory set to a standard configuration (see “Function Table” for default settings). Like all other RT4 series instruments the configuration and calibration is easily changed by the user.

The RT4 series instruments are designed for high reliability in industrial applications. The IP65 rated enclosure makes the instrument suitable for use in many different environments. The high contrast LCD provides good visibility.

## 2 Mechanical Installation

### Mechanical Installation

The RT4 is designed to be wall mounted via four screws, obtain screws to suit the surface on which the RT4 is to be mounted, the holes in the case through which the screws must pass have a 4.4mm diameter. To gain access to the screw holes the instruments front cover must be removed. Mounting details are as show below.

When choosing a location for mounting the instrument try to avoid areas close to heavy electrical interference such as welders, fluorescent lights, heavy motors etc.

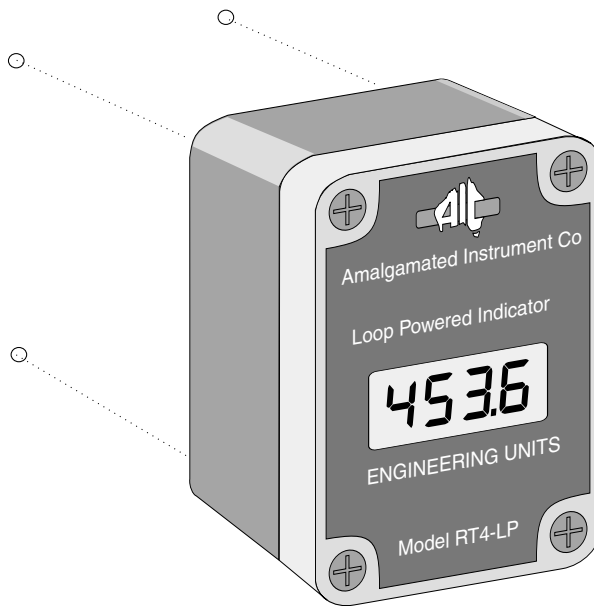
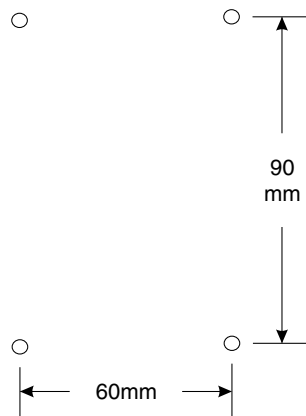

### 3 Electrical Installation

#### Electrical Installation

Electrical connections to the RT4-LP are made via connectors at the rear of the main circuit board as shown below. Connectors are screw type which accept wires up to 2.5mm<sup>2</sup>. Cable entry is via housing mounted cable glands.

The instrument is 4-20mA loop powered with 3V nominal voltage drop.

Wherever possible site the instrument away from areas of heavy electrical noise, use screened cable grounded at the RT4 end and do not run the cable near high voltage cables.

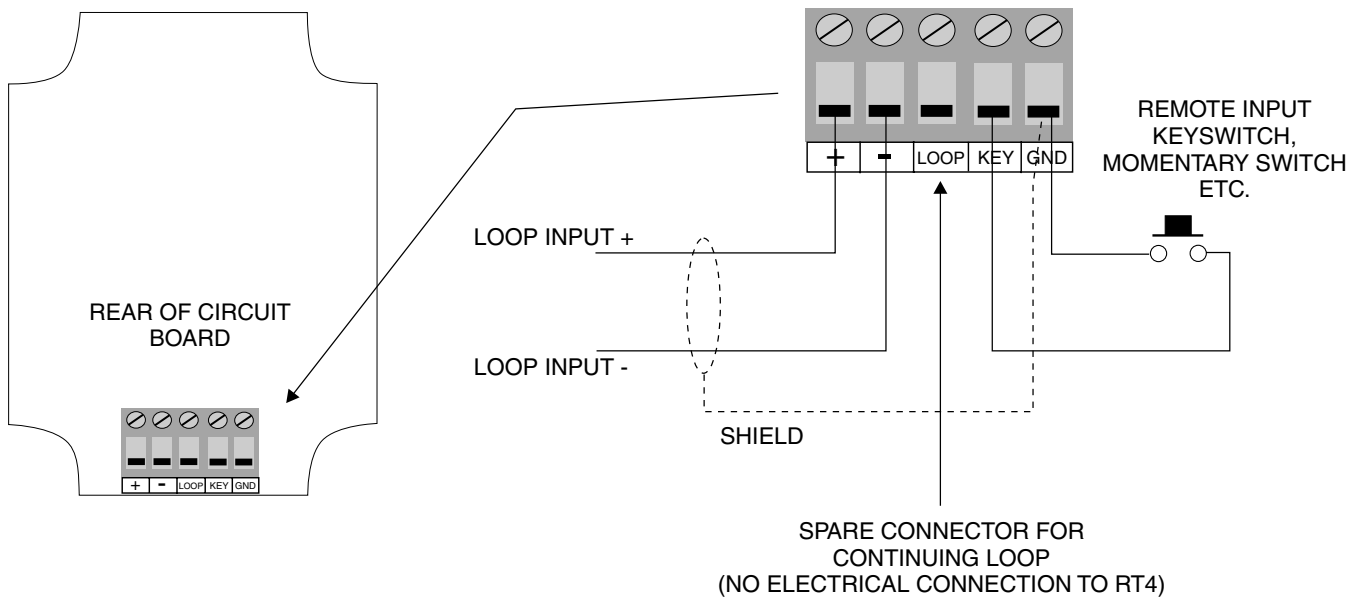

## 4 Explanation of Functions

The RT4-LP setup and calibration functions are configured through a push button sequence. Two levels of access are provided for setting up and calibrating:

**FUNC** mode (simple push button sequence) allows access to commonly set up functions,

**CAL** mode (power up sequence plus push button sequence) allows access to all functions including calibration parameters.

To alter setup or calibration functions first remove the instruments front cover by loosening the four screws located at the front corner. The three push buttons located on the circuit board just below the display are used to alter settings. Once you have entered either **CAL** or **FUNC** mode you step through the functions, by pressing and releasing the **F** push button, until the required function is reached. Changes to functions are made by pressing the **▲** or **▼** push button when the required function is reached.

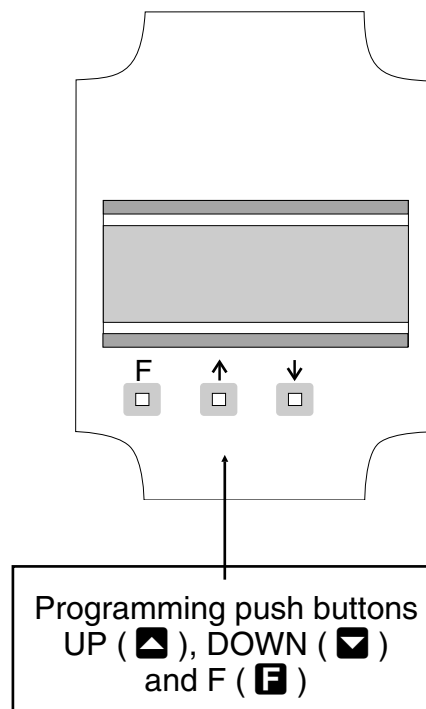

### Entering **CAL** Mode

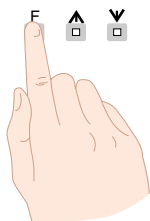

1. Remove power from the instrument. Hold in the **F** button and reapply power. The display will indicate **CAL** as part of the "wake up messages" when the **CAL** message is seen you can release the button.

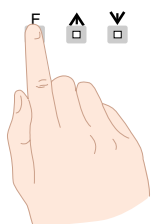

2. When the "wake up" messages have finished and the display has settled down to its normal reading press, then release the **F** button.

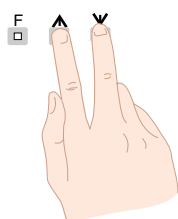

3. Within 2 seconds of releasing the **F** button press, then release the **▲** and **▼** buttons together. The display will now indicate **FUNC** followed by the first function.

Note: If step 1 above has been completed then the instrument will remain in this **CAL** mode state until power is removed. i.e. there is no need to repeat step 1 when accessing function unless power has been removed.

### Entering **FUNC** Mode

No special power up procedure is required to enter **FUNC** mode.

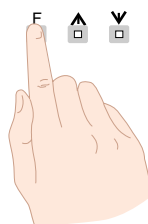

1. When the "wake up" messages have finished and the display has settled down to its normal reading press, then release the **F** button.

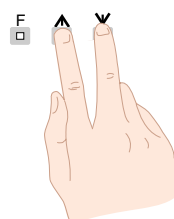

2. Within 2 seconds of releasing the **F** button press, then release the **▲** and **▼** buttons together. The display will now indicate **FUNC** followed by the first function.

## 4.1 Set up functions.

The set up functions shown below are accessible via **FUNC** mode entry.

### **d r n d** (display rounding)

Displays and sets the display rounding value. This value may be set to 0 - 5000 displayed units. Display rounding is useful for reducing the instrument resolution without loss of accuracy, in applications where it is undesirable to display to a fine tolerance. (example if set to **10** the instrument will display in multiples of 10).

### **d C P t** (decimal point selection)

Displays and sets the decimal point. By pressing the **▲** or **▼** push buttons the decimal point position may be set. The display will indicate as follows: **0** (no decimal point), **0. 1** (1 decimal place), **0.002** (2 decimal places), **0.003** (3 decimal places).

### **F L t r** (digital filter)

Displays and sets the digital filter value. Digital filtering is used for reducing susceptibility to short term interference. The digital filter range is selectable from 0 to 8, where **0** = none and **8** = most filtering. A typical value for the digital filter would be 3.

### **S P F n** (special function)

Displays and sets the special function. To operate the special function there must be a remote input contact closure between the "KEY" and "GND" connectors at the rear of the circuit board. See Chapter 3 "Electrical Installation" for diagrams. The special functions available are:

#### **n o n e** (no special function)

When this function is selected the remote input will have no effect.

#### **P H L d** (peak hold)

With peak hold selected the display will show the peak input reading starting from the time the remote input was closed. Opening the remote input will cause the display to revert to normal reading. A latching switch would normally be used as the remote input if peak hold is being monitored for any length of time.

#### **d H L d** (display hold)

The display hold special function will cause the display to hold its current display when the remote input is closed. The display will be held for as long as the switch remains closed. Opening the remote input will cause the display to revert to normal reading.

#### **M** (peak memory value)

The peak memory function will cause the display to show the peak reading which has occurred since the instrument was last switched on or was last reset (to reset the memory hold the remote input closed for 1 to 2 seconds). A momentary operation of the remote input will cause the peak memory function to operate **M** will flash every few seconds followed by the peak value in memory. The display will revert to normal reading after approximately 20 seconds.

#### **L V** (valley memory value)

The valley memory function will cause the display to show the lowest reading which has occurred since the instrument was last switched on or was last reset (to reset the memory hold the remote input closed for 1 to 2 seconds). A momentary operation of the remote input will cause the valley memory function to operate **L V** will flash every few seconds followed by the lowest value in memory. The display will revert to normal reading after approximately 20 seconds.

### **S q r t** (square root)

The square root function may be turned on or off (displayed as **ON** or **OFF**). When set to **OFF** the calibrated input will be displayed in its normal linear fashion. When set to **ON** the display will show the input as the square root of the percentage of the full scale value. For example if 4mA (0% of the input) is scaled to read **0** and 20mA (100% of the input) is scaled to read **1000** then with the square root function set to **ON** the display will indicate as follows.

At 20mA (100%) the display will be **1000** i.e.  $\sqrt{1} \times 1000$ .

At 16mA (75%) the display will be **866** i.e.  $\sqrt{0.75} \times 1000$ .

At 12mA (50%) the display will be **707** i.e.  $\sqrt{0.50} \times 1000$  and so on.

## 4.2 Calibration functions

The set up functions shown below are accessible via **CAL** mode entry only.

### **CAL 1 & CAL 2** (calibration using 2 points, see also **OFFSE** and **SCALE** functions)

Displays and sets the two independent calibration points. In this method of calibration two known inputs will be required (**CAL 1** and **CAL 2**) from a transmitter or current generator. The display values for these two inputs must be known and entered (**SCALE 1** and **SCALE 2**). These two inputs must not be close together. Ideally they should be 4mA and 20mA. The two calibration points can be entered at different times i.e. it is not necessary to enter both points in one operation.

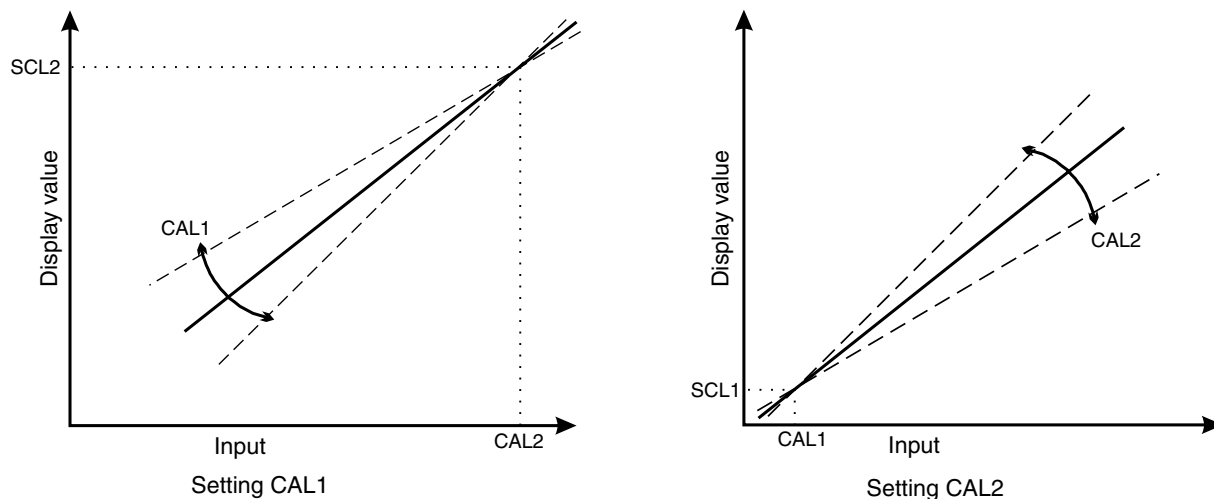

The calibration procedure is as follows:

1. Apply a known input current to the instrument e.g. 4mA
2. Enter via **CAL** mode and step through the functions until the display shows **CAL 1**.
3. Press, then release, the **▲** and **▼** pushbuttons simultaneously. The display will now indicate the "live" input value and **CAL 1** will flash momentarily every few seconds. When the display indication is showing a steady reading (do not worry about the actual reading at this stage) press, then release the **■** button.
4. The display will now indicate **SCALE 1** (scale 1) followed by the previous scale value for this input. Use the **▲** or **▼** push button to alter this value, if required i.e. alter this to show the required reading for this input.
5. Press, then release, the **■** push button to accept the new value. The display will indicate **CAL End** followed by **CAL 2**.
6. If you do not wish to enter the second calibration point at this stage then press **■** to step onto the next function (**OFFSE**).

If you wish to proceed with the second calibration point then apply the second known input current e.g. 20mA.

7. Press, then release, the **▲** and **▼** pushbuttons simultaneously. The display will now indicate the "live" input value and **CAL 2** will flash momentarily every few seconds. When the display indication is showing a steady reading (do not worry about the actual reading at this stage) press, then release the **■** button.
8. The display will now indicate **SCALE 2** (scale 2) followed by the previous scale value for this input. Use the **▲** or **▼** push button to alter this value, if required i.e. alter this to show the required reading for this second input.
9. Press, then release, the **■** push button to accept the new value. The display will indicate **CAL End**, indicating that calibration is complete and the instrument will return to normal measure mode.

### OFFSE (offset calibration)

Allows the instrument calibration to be offset by a single point value. This value is added or subtracted equally across the range of the instrument. To gain access to the **OFFSE** function press, then release, the **▲** and **▼** push buttons simultaneously. The display will then indicate the existing reading. Press and release the **■** push button, the display will indicate **SCALE** followed by the scale value in memory. Use the **▲** or **▼** push button to enter the required offset. For example if the display was indicating **55.0** for a given input and it is known that this reading should be **60.0** at that input then use the **▲** or **▼** push button to change the **SCALE** value to **60.0**.

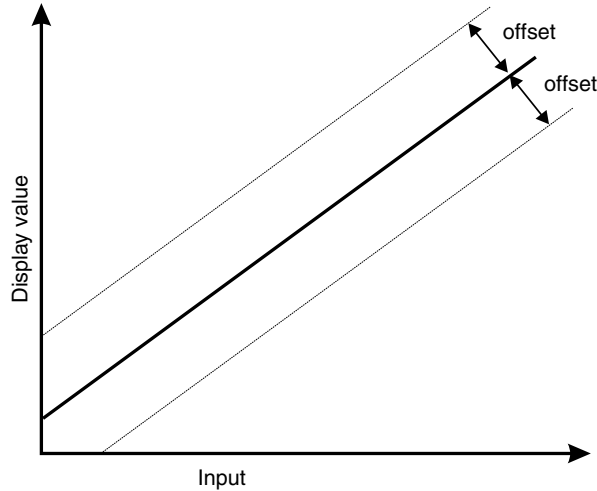

### SCALE (input scaling by keying in 4-20mA (or 10-50mA) values)

The instrument may be scaled without using test equipment or live input signals via this function. When the **SCALE** function is reached press, then release, the **▲** and **▼** push buttons together. The message **En4** (or **En10**) (this means enter the value to be displayed for a 4mA (or 10mA) input) will then be displayed followed by the 4mA (or 10mA) value currently stored. Use the **▲** or **▼** push button to change this value if required. Press and release the **■** push button. The message **En20** (or **En50**) (this means enter the value to be displayed for a 20mA (or 50mA) input) will then be displayed followed by the 20mA (or 50mA) value currently stored. Use the **▲** or **▼** push button to change this value if required. Press and release the **■** push button again to accept these changes, the display will indicate **CAL End** followed by **FUNC End** and will then return to normal measure mode.

### UNCAL (uncalibration)

Used to set the instrument back to the factory calibration values. This function should only be used when calibration problems exist, and it is necessary to clear the calibration memory. To perform an uncalibration press, then release the **▲** and **▼** push buttons simultaneously when the display is indicating **UNCAL**. The message **CAL CLR** will be shown to indicate that uncalibration is complete.

### INP (select input range)

This function allows the selection of either 4-20mA or 10-50mA inputs. Select **4-20** for 4-20mA or **10.50** for 10-50mA.

## 4.3 Returning to the normal measure Mode

Important; when the calibration is complete, it is advisable to return the instrument to the normal mode (where calibration functions cannot be tampered with). To return to the normal mode - turn off the instrument power by removing the loop connection - wait a few seconds and the restore power.

## 5 Function Table

Initial display	Meaning of display	Next display	Default setting	Record Your Settings
<i>drnd</i>	Display rounding	Value in memory	<b>1</b>	
<i>dCPE</i>	Decimal point places	<b>0, 0.1, 0.02 or 0.003</b>	<b>0</b>	
<i>FLtr</i>	Digital filter	<b>0 to 8</b>	<b>3</b>	
<i>SPFN</i>	Special function	<b>NONE PHLd dHLd H, Lo</b>	<b>NONE</b>	
<i>SqRt</i>	Square root extractor	<b>on or OFF</b>	<b>OFF</b>	
<i>CAL1</i>	First calibration point	n/a	n/a	
<i>CAL2</i>	Second calibration point	n/a	n/a	
<i>OFFst</i>	Calibration offset	Value in memory	n/a	
<i>SCLE</i>	Scale (calibration by entering in display values for 4 and 20mA)	n/a	n/a	
<i>UCAL</i>	Uncalibration	n/a	n/a	
<i>INPE</i>	Input range 4-20mA or 10-50mA	<b>4-20 or 10.50</b>	<b>4-20</b>	

Functions shown shaded are accessible only when in the power up (Calibration) mode, see “Calibration” chapter

---

## 6 Examples and Trouble Shooting

---

This first section of this chapter gives examples of setting up the RT4-LP, the second section is concerned with dealing with problems which may be encountered.

### 6.1 Examples

#### Example 1 - Changing the digital filter setting.

The digital filter setting is set at five, this is to be altered to two.

1. Enter the function mode as described in the "Explanation of Functions" chapter. The display will indicate **FUNC** followed by **drnd** (the first function).
2. Step through the functions, by pressing and releasing **F** until the display shows **FLtr**.
3. When **FLtr** is reached after 1 second or so the display will indicate **5** (the digital filter setting currently selected). Use the **▼** push button to alter this to **2**.
4. Press, then release, **F** to accept the change to the setting and continue pressing and releasing **F** until the display returns to normal measure mode.

#### Example 2 - Two point calibration.

The current calibration has display values of **0.0** for a 4mA input and **100.0** for a 20mA input, this is to be altered so that a 4mA input will give a display of **20** and a 20mA input will give a display value of **1000**. Note that the decimal point position will also need to be changed.

1. Enter via **CAL** mode as described in the "Explanation of Functions" chapter. The display will indicate **FUNC** followed by **drnd** (the first function).
2. Step through the functions, by pressing and releasing **F** until the display shows **dCPL**.
3. The decimal point function will now indicate **0.1** (1 decimal point place), change this to **0** by using the **▼** push button.
4. Step through the functions, by pressing and releasing **F** until the display shows **CAL 1**.
5. Apply 4mA to the input.
6. Enter the **CAL 1** function by pressing, then releasing, the **▲** and **▼** push buttons simultaneously.
7. The display will now indicate the "live" reading i.e. the scaled value for 4mA. When this reading is steady press, then release **F**.
8. The display will indicate **SCALE 1** (first scale value) followed by the old scale value, change this to **20** using the **▲** push button.
9. Press, then release **F**. The display will show **CAL End** followed by **CAL 2**.
10. Apply 20mA to the input.
11. Enter the **CAL 2** function by pressing, then releasing, the **▲** and **▼** push buttons simultaneously.
12. The display will now indicate the "live" reading i.e. the scaled value for 4mA. When this reading is steady press, then release **F**.
13. The display will indicate **SCALE 2** (first scale value) followed by the old scale value, change this to **1000** using the **▲** push button.
14. Press, then release **F**. The display will indicate **CAL End** and the display will return to its normal measure mode.

#### Example 3 - calibration by entering the 4 and 20mA display values.

The **SCALE** function allows simple scaling by entering the values to be displayed at 4 and 20mA. This allows scaling without live inputs or test equipment. The instrument is currently set up to display **0.0** at 4mA and **100.0** at 20mA, this is to be altered to display **0.0** at 4mA and **500.0** at 20mA.

1. Enter via **CAL** mode as described in the "Explanation of Functions" chapter. The display will indicate **FUNC** followed by **drnd** (the first function).
2. Step through the functions, by pressing and releasing **F** until the display shows **SCALE**.
3. Enter the **SCALE** function by pressing, then releasing, the **▲** and **▼** push buttons simultaneously.
4. The display will indicate **En4** (enter the value to be displayed for a 4mA input) followed by the old setting (**0.0**), there is no need to alter this so step through by pressing and releasing **F**.
5. The display will indicate **En20** (enter the value to be displayed for a 20mA input) followed by the old setting (**100.0**). Use the **▲** pushbutton to change this reading to **500.0**.
6. Press, then release **F**. The display will indicate **CAL End** and the display will return to its normal measure mode.

## 6.2 Trouble shooting

The RT4-LP is a 2 wire, 4-20mA or 10-50mA loop powered indicator, the instrument requires power from the loop to operate. The voltage drop across the loop input terminals is 3V nominal at 20mA and 3.5V at 50mA.

The following examples show possible operation problems which may occur with suggested remedies.

**1. No display indication** - Check that the instrument is connected correctly to the loop, if the wires are crossed the instrument will not power up. Check that the loop has sufficient voltage, other instruments in the loop will cause voltage drops and eventually there will not be sufficient voltage to drive the loop.

**2. display indication** - The four bars indicate that the input current is overrange i.e. it is much greater than 20mA, check the loop current using an ammeter.

-**or**- display indication - These characters indicate that the display has gone over its maximum display value e.g. has gone beyond 9999, 999.9 etc. This could be due to the input going above its expected maximum value e.g. if the display has been scaled to read 9999 at 10mA then any input above 10mA will cause a -**or**- display. Check the input current. If you are using the full 4-20mA input and the display is indicating -**or**- then, having checked that the input is not actually going above 20mA, you will need to recalibrate the instrument.

**3. Display reading changes in steps e.g. multiples of 20** - Check the display rounding function, this can be set to cause the display to change in steps.

**4. Display reading fluctuates with a steady input** - The usual cause of this is electrical noise picked up on the input cable. Try increasing the digital filter function setting to minimise the noise problem. The use of screened input cable, earthed at the RT4 end only will minimise the amount of noise picked up. For high levels of electrical noise it may be necessary to ensure that the screened cable is run as far away from any possible from any sources of electrical noise and that the instrument itself is sited away from noise sources. Typical high noise sources include fluorescent lights, electric welders and electric motors.

---

## 7 Specifications

---

### Technical Specifications

Input:	4-20mA (10-50mA also available to order)
Current Range	3.5 to 50mA measurable
Loop voltage drop:	3V nominal
Input protection:	150mA either direction
Display range:	-1999 to 9999 full 4 digit -19999 to 19999 4.5 digit
Accuracy:	0.025% of full scale when calibrated
Sample Rate:	4 per sec (approx)
A/D Converter:	Dual slope integration
Microprocessor:	MC68705C8 CMOS
Ambient Temperature:	-10 to 50°C
Humidity:	5 to 95% non condensing
Display:	LCD 4 digit 12.7mm or LCD 4.5 digit 10.2mm
Power Supply:	Loop powered (4-20mA)
Physical Characteristics	
Case Size:	110mm (h) x 80mm (w) x 68mm (d)
Connections:	Loop Input - Two screw terminals (max 1.5mm wire) Keypress - Screw terminal (max 1.5mm wire) Loop - Screw terminal (max 1.5mm wire) Ground - Screw terminal (max 1.5mm wire)
Mounting Holes:	90mm (h) x 60mm (w)
Weight:	300 gms unpacked

---

## 8 Guarantee and Service

---

The product supplied with this manual is guaranteed against faulty workmanship for a period of 2 years from the date of dispatch.

Our obligation assumed under this guarantee is limited to the replacement of parts which, by our examination, are proved to be defective and have not been misused, carelessly handled, defaced or damaged due to incorrect installation. This guarantee is VOID where the unit has been opened, tampered with or if repairs have been made or attempted by anyone except an authorised representative of the manufacturing company.

Products for attention under guarantee (unless otherwise agreed) **must be returned to the manufacturer freight paid** and, if accepted for free repair, will be returned to the customers address in Australia free of charge.

When returning the product for service or repair a full description of the fault and the mode of operation used when the product failed must be given.

In any event the manufacturer has no other obligation or liability beyond replacement or repair of this product.

Modifications may be made to any existing or future models of the unit as it may deem necessary without incurring any obligation to incorporate such modifications in units previously sold or to which this guarantee may relate.

This document is the property of  
the instrument manufacturer  
and may not be reproduced in whole or part without  
the written consent of the manufacturer.

This product is designed and manufactured in Australia.