

Model RM4-WT
DIN Rail Mount Display/Controller
Operation and Instruction Manual

AMALGAMATED INSTRUMENT CO PTY LTD

ACN: 001 589 439

*Unit 5, 28 Leighton Place Hornsby
NSW 2077 Australia*

*Telephone: +61 2 9476 2244
Facsimile: +61 2 9476 2902*

*e-mail: sales@aicpl.com.au
Internet: www.aicpl.com.au*

Table of Contents

1	Introduction	3
2	Mechanical installation	4
3	Electrical installation	5
4	Function tables - summary of setup functions	9
5	Explanation of functions	13
6	Calibration	35
7	Batching operation	40
8	Specifications	42
9	Guarantee and service	44

1 Introduction

1.1 General description

This manual contains information for the installation and operation of the RM4-WT Load Cell Monitor. Model RM4-WT is a high precision load cell/strain gauge monitor which may be configured to accept an input from any conventional 4 wire strain gauge bridge of 85Ω or higher. Sample rate is programmable in steps from 5 to 100 samples per second. The instrument has range settings of 0.5mV/V to 100mV/V selectable in steps.

The RM4-WT has various calibration method options. It may be calibrated by applying known weights to the load cell or by entering the mV/V value for the load cell or via a single offset value or via a “remote input” live calibration. Excitation voltages of 5 volt and 10 volt are selectable by PCB links.

The RM4 is suitable for measuring weight, pressure, force, torque and similar variables. Calibration, setpoint and other set up functions are easily achieved using the keypad to access the appropriate functions. Two standard inbuilt relays provide alarm/control functions. Various combinations of one or two optional extra relays, analog (4-20mA, 0-1V or 0-10V) retransmission or serial (RS232, RS485 or RS422) communications may also be provided as an option.

Unless otherwise specified at the time of order, your RM4 has been factory set to a standard configuration. Like all other RM4 series instruments the configuration and calibration is easily changed by the user. Initial changes may require dismantling the instrument to alter PCB links, other changes are made by push button functions.

Full electrical isolation between power supply, input and retransmission output is provided by the RM4, thereby eliminating grounding and common voltage problems. This isolation feature makes the RM4 ideal for interfacing to computers, PLCs and other data acquisition devices.

The RM4 series of DIN Rail Process Modules are designed for high reliability in industrial applications. The 5 digit LED display provides good visibility, even in areas with high ambient light levels. A feature of the RM4-WT is the programmable display brightness function, this allows the unit to be operated with low display brightness to reduce the instrument power consumption and to improve readability in darker areas. To reduce power consumption in normal use the display can be programmed to automatically dim or blank after a set time.

1.2 Output options

- One or two extra relays, rated 0.5A at 30VAC or 30VDC
- Analog retransmission configurable for 4–20mA, 0–1V or 0–10V. Configurable for retransmission or PI control. 12 or 16 bit versions available
- RS232, RS485 or RS422 (factory configured) serial communications (ASCII or Modbus RTU)
- Isolated and regulated transmitter supply. Selectable 12VDC (50mA max.) or 24VDC (25mA max.)
- Switched non isolated 24VDC output (25mA max.) or open collector output (25VDC max., 250mA max.), factory configured.

2 Mechanical installation

The RM4 is designed for DIN rail, horizontal mounting. The instrument clips on to 35mm DIN standard rails (EN50022). Cut the DIN rail to length and install where required. To install the RM4 simply clip onto the rail as shown below. To remove the RM4 lever the lower arm downwards using a broad bladed screwdriver to pull the clip away from the DIN rail.

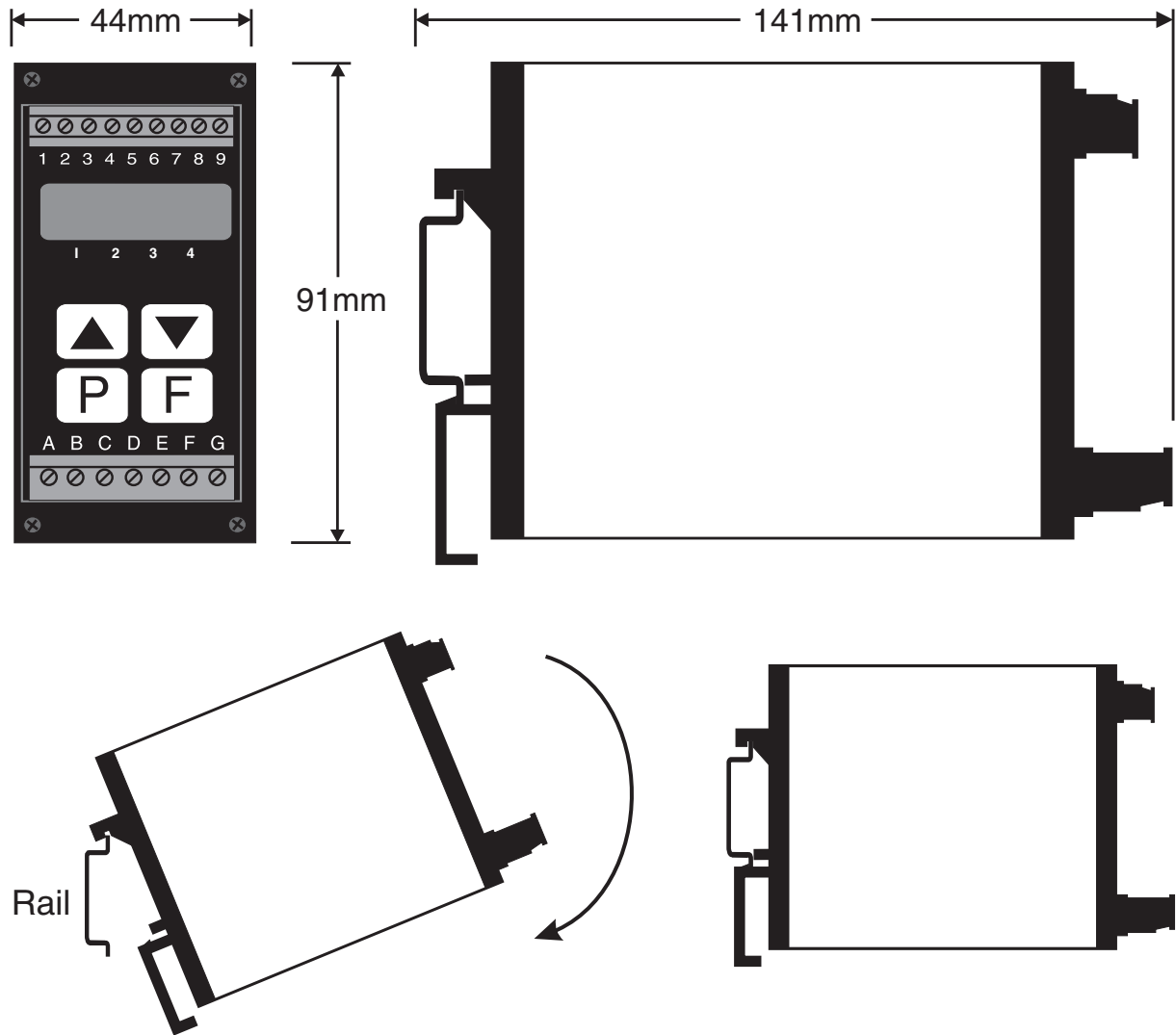

3 Electrical installation

The RM4 Meter is designed for continuous operation and no power switch is fitted to the unit. It is recommended that an external switch and fuse be provided to allow the unit to be removed for servicing. The terminal blocks allow for wires of up to 2.5mm² to be fitted for power supply and relays 1 and 2 or 1.5mm² for input connections and optional outputs. Connect the wires to the appropriate terminals as indicated below.

Refer to connection diagrams provided in this manual to confirm proper selection of voltage, polarity and input type before applying power to the instrument. When power is applied the instrument will cycle through a display sequence, indicating the software version and other status information, this indicates that the instrument is functioning. Acknowledgement of correct operation may be obtained by applying an appropriate input to the instrument and observing the resultant reading.

Note that the power supply type is factory configured. Check power supply type before connecting. Relay outputs are voltage free contacts.

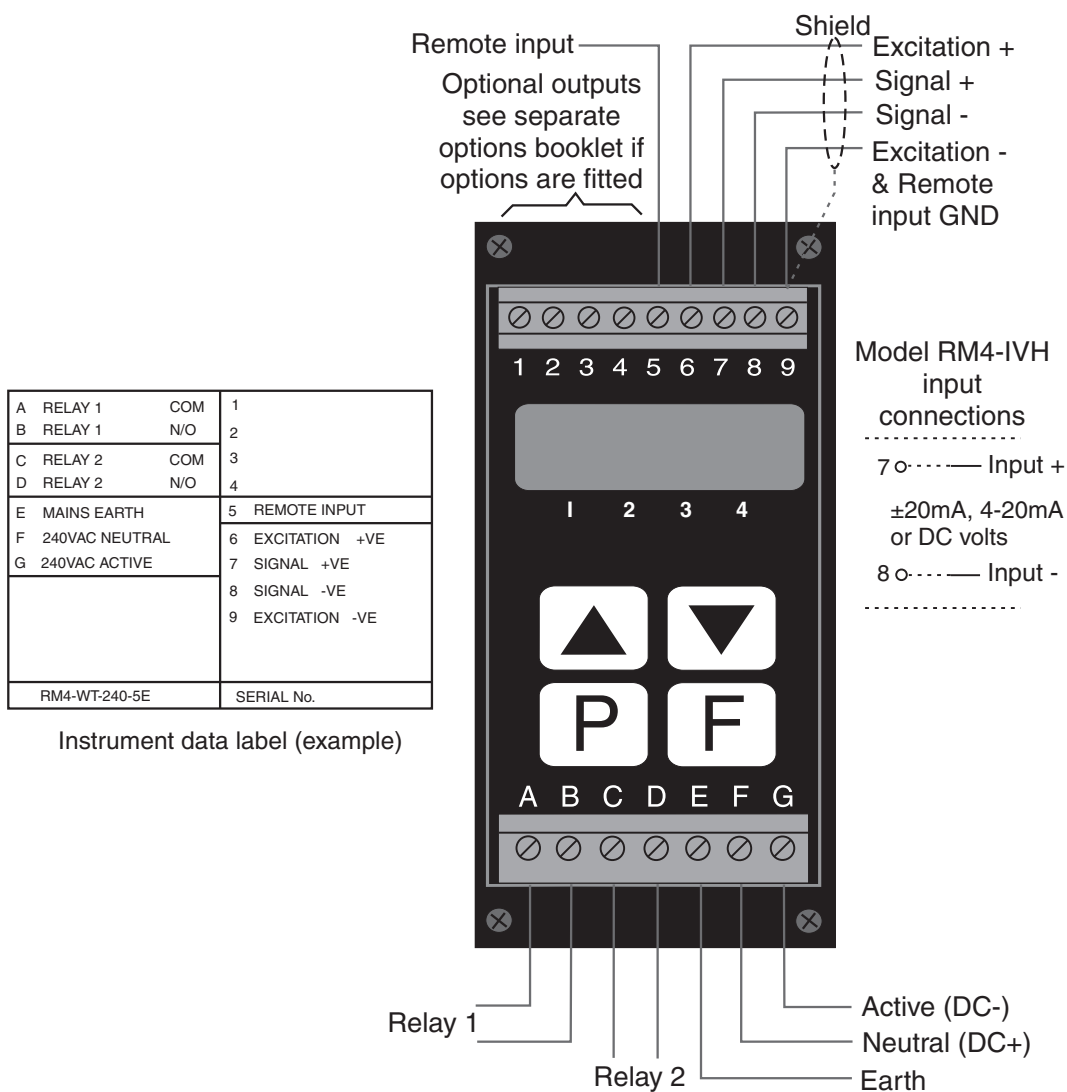

3.1 Load cell connection using internal excitation.

When connecting load cells in parallel (or using a low resistance bridge) the input resistance of the load cell combination must not be lower than 85Ω irrespective unless external excitation is used. See section 3.4 for details of link settings for excitation voltage selection and external excitation.

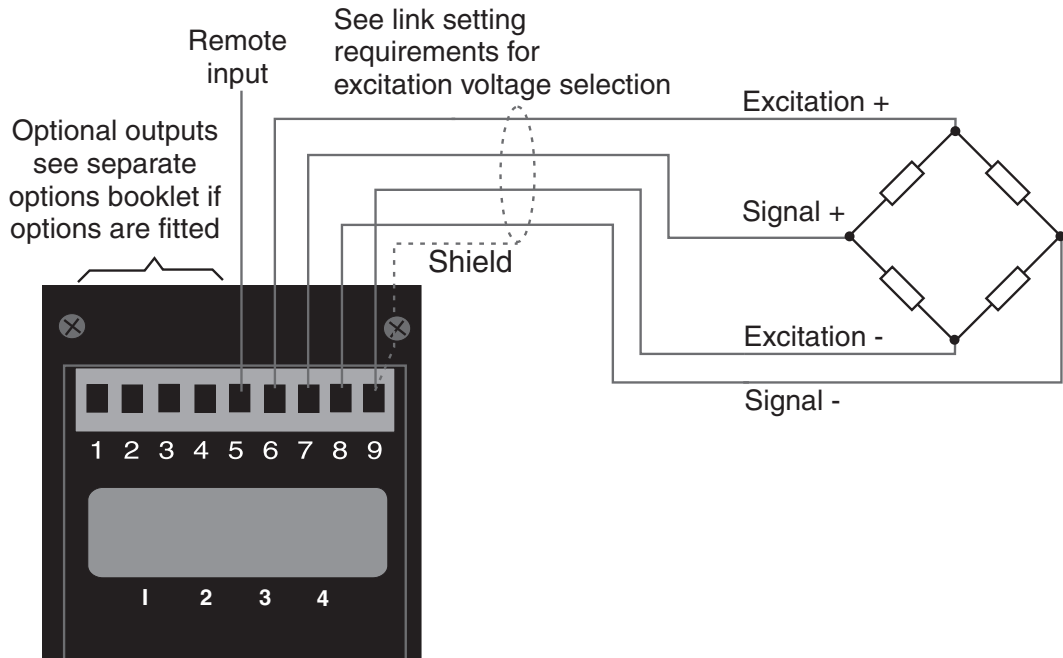

3.2 Load cell connection using external excitation

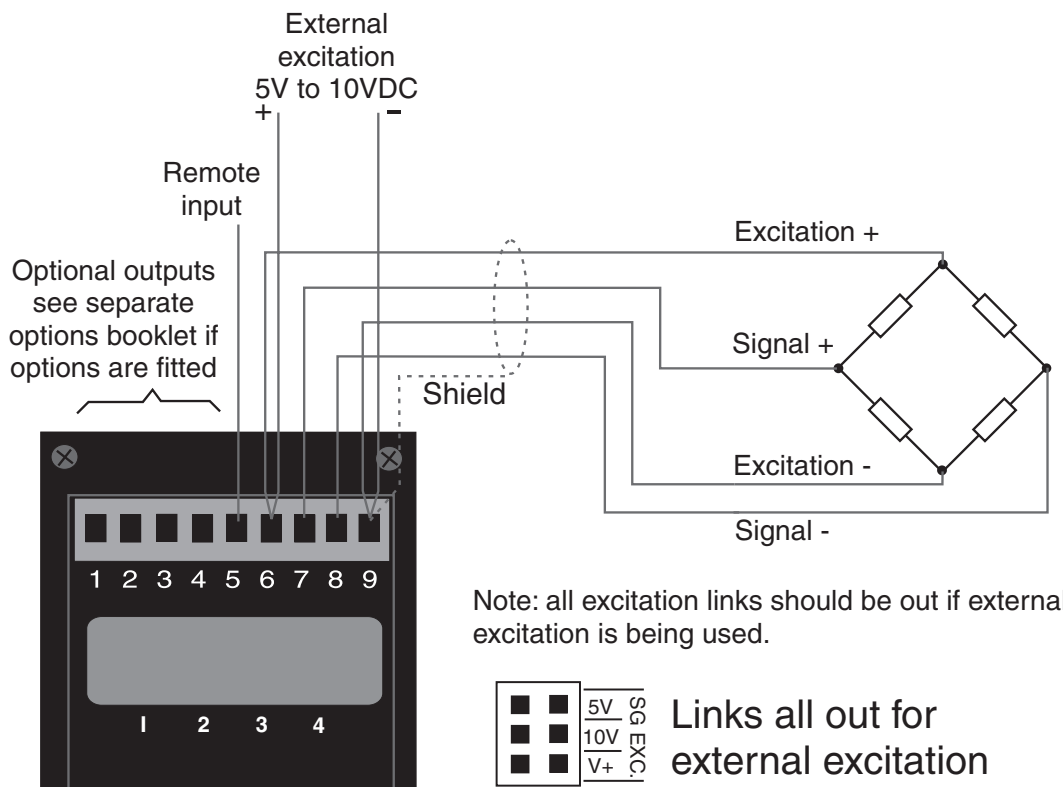

3.3 Remote input connections

The selected remote input function can be operated via an external contact closure via a switch, relay or open collector transistor switch. A momentary action is required for functions such as **LRFE** and **ZER0**, a latching switch or normally closed momentary switch may be required for functions such as peak hold (**P.HLD**).

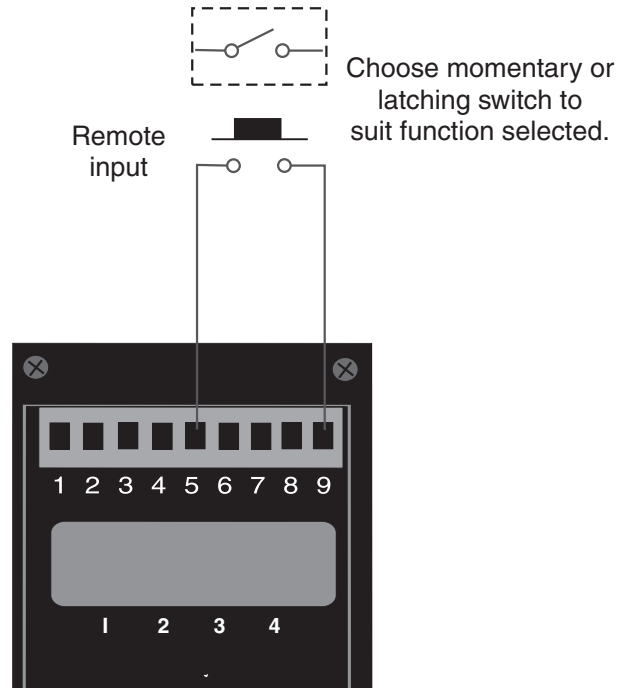

3.4 Configuring the input board

Remove the circuit board from the case following the instructions below. Link settings for the main input board are as shown below. For optional output link settings consult the separate “RM4 DIN Rail Meter Optional Output Addendum” booklet. The minimum resistance of any load cell or combination of load cells connected to the input is 85Ω unless external excitation is used. This applies to both 5V and 10V excitation.

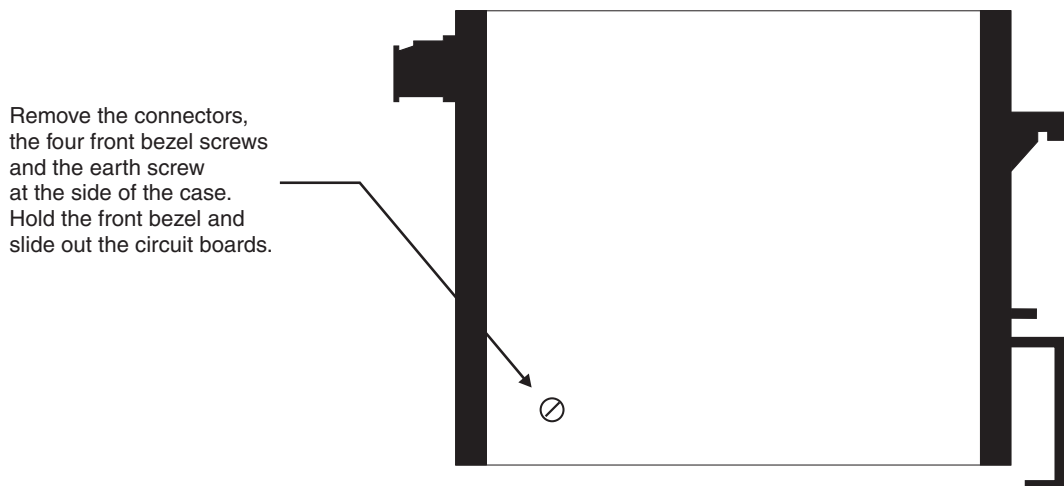

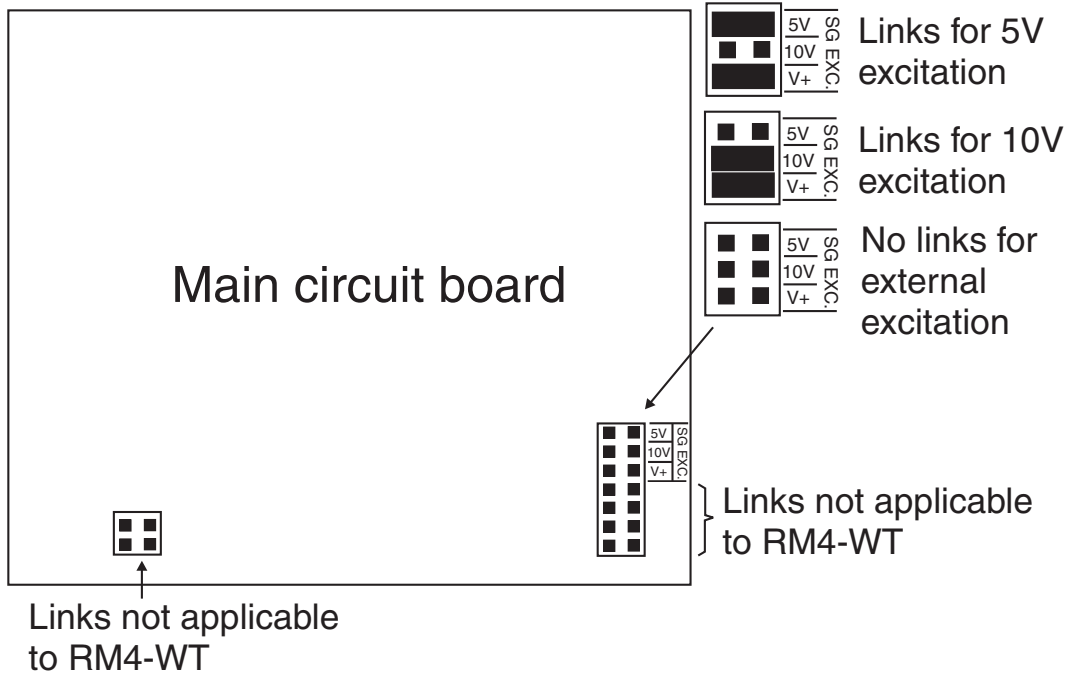

4 Function tables - summary of setup functions

Note: the order in which the functions appear on the display may not be exactly as shown below. The availability and order of functions is determined by choice of function settings and options fitted.

Functions in this first table are available in **FUNC** or **CAL** mode

Display	Function	Range	Default	Your record	Ref/Page
RxLo	Low setpoint value for designated alarm relay <i>x</i>	Any display value or OFF	OFF	See 4.1	5.1 / 15
RxH.	High setpoint value for designated alarm relay <i>x</i>	Any display value or OFF	OFF	See 4.1	5.2 / 15
RxHY	Hysteresis value for the designated alarm relay <i>x</i> .	0 to 9999	10	See 4.1	5.3 / 16
Rxtt	Trip time delay for the designated alarm relay <i>x</i> .	0 to 9999	0	See 4.1	5.4 / 17
Rxrt	Reset time delay for the designated alarm relay <i>x</i> .	0 to 9999	0	See 4.1	5.5 / 17
Rxn.o or Rxn.c	Alarm relay <i>x</i> action to normally open (de-energised) or normally closed (energised)	Rxn.o or Rxn.c	Rxn.o	See 4.1	5.6 / 17
RxSP or Rxt i etc.	Relay operation independent setpoint or trailing setpoint (*Optional)	RxSP or Rxt i etc.	RxSP	See 4.1	5.7 / 18
brgt	Display brightness level	1 to 15	15		5.8 / 18
dull	Display remote brightness switching	0 to 15	1		5.9 / 18
d.off SECS	Auto display dimming timer	0 to 9999	0		5.10 / 19
Rx FREE	Alarm relay “free fall” or “in flight” value	Any display value	0	See 4.1	5.11 / 19
FEC-	Analog output option low display value (*Optional)	Any display value	0		5.12 / 19
FEC+	Analog output option high display value (*Optional)	Any display value	1000		5.13 / 20
P.SET	Preset value	Any display value	0		5.14 / 20
CL.no	Calibration number selection	CAL. 1 or CAL. 2	CAL. 1		5.15 / 21

(*Optional)—this function will only be accessible if the relevant option is fitted

Functions in this second table are available only in **CAL** mode or if **ACCS** is set to **ALL**

Display	Function	Range	Default	Your record	Ref/Page
drnd	Display rounding	1 to 5000	1		5.16 / 21
dCPt	Decimal point	0, 0.1 etc.	0		5.17 / 22
FLtr	Digital filter	0 to 8	2		5.18 / 22
rEc ctri	Analog output PI control (*Optional)	on or OFF	OFF		5.19 / 22
FRtE	Sample rate in samples/sec.	5, 10, 15, 20, 30, 40, 50, 60, 80 or 100	10		5.20 / 23
FRGE	mV/V input range	0.5, 1.0, 2.5, 5.0, 10, 25, 50 or 100	2.5		5.21 / 23
FINP	Remote input (external input) one function	NONE, P.HLd, d.HLd.H, Lo.H, Lo, tRGE, ZER0, SP.Ac, No.Ac, CAL.S .P.SET, I.CAL, btch, CAL, or dULL	NONE		5.22 / 23
Pbut	P button function	NONE.H, Lo.H, Lo, tRGE, ZER0, CAL.S.P.SET or btch	NONE		5.23 / 25
ACCS	Access mode	OFF, EASY, NONE or ALL	OFF		5.24 / 25
SPAC	Setpoint access mode (*Optional)	A1, A1-2 etc.	A1		5.25 / 25
Lin PtS	Lineariser points, allows up to 5 calibration points	2, 3, 4 or 5	2		5.26 / 26
FREE ACCS	Easy access for alarm relay free fall	on or OFF	OFF		5.27 / 26
CAL1	First live calibration point	Any display value	n/a		5.28 / 26
CAL2	Second live calibration point	Any display value	n/a		5.29 / 26

(*Optional)—this function will only be accessible if the relevant option is fitted

CAL3	Third live calibration point	Any display value	n/a		5.30 / 27
CAL4	Fourth live calibration point	Any display value	n/a		5.31 / 27
CAL5	Fifth live calibration point	Any display value	n/a		5.32 / 27
ECAL	mV/V entry scaling method	- 19.999 to 32.000	1.000		5.33 / 27
CAL OFFSt	Calibration offset	Any display value	n/a		5.34 / 27
SEt ZER0	Sets zero calibration point	Any display value	n/a		5.35 / 28
ZER0 RANGE	Zero range limit	Any display value or OFF	OFF		5.36 / 28
CAL ZER0 RANGE	Zero reference point for ZER0 RANGE operation	n/a	n/a		5.37 / 28
Aut0 ZER0	Auto zero range	0 to 100	0		5.38 / 28
A.Z. cnt	Auto zero sample count	10 to 100	10		5.39 / 28
Al.R2 etc.	Alarm relay operation mode	L, uE, tARtE, btch, P.HLd, d.HLd, H, Lo or di SP	L, uE	See 4.1	5.40 / 29
r-EC	Analog operation mode (*Optional)	L, uE, tARtE, btch, P.HLd, d.HLd, H, Lo or di SP	L, uE		5.41 / 30
Lo di SP	Low overrange visual warning limit value	Any display value or OFF	OFF		5.42 / 31
Hi GH di SP	High overrange visual warning limit value	Any display value or OFF	OFF		5.43 / 31
di SP	Display visual warning flashing mode	FLSH or -or-	FLSH		5.44 / 31
bAUD RATE	Baud rate for serial communications (*Optional)	300.600. 1200.2400. 4800.9600. 19.2 or 38.4	9600		5.45 / 32
Prty	Parity for serial communications (*Optional)	NONE.EVEN or odd	NONE		5.46 / 32

(*Optional)—this function will only be accessible if the relevant option is fitted

O.Put	Output for serial communications (*Optional)	di SP.Cont. POLL or ̄.buS	Cont		5.47 / 32
Addr	Instrument address for serial communications (*Optional)	0 to 31	0		5.48 / 33

(*Optional)—this function will only be accessible if the relevant option is fitted

4.1 Relay table

Record your relay settings in the table below

Display	Relay 1	Relay 2	Relay 3	Relay 4	Relay 5	Relay 6	Relay 7
RxLo							
RxH,							
RxHY							
Rxtt							
Rxrt							
Rxn.o or Rxn.c							
RxSP or Rxt i etc.	n/a						
Rx FREE							
R1, R2 etc.							

5 Explanation of functions

The RM4 setup and calibration functions are configured through a push button sequence. The push buttons located at the front of the instrument are used to alter settings. Two basic access modes are available:

FUNC mode (simple push button sequence) allows access to commonly set up functions such as alarm setpoints.

CAL mode (power up sequence plus push button sequence) allows access to all functions including calibration parameters.

Once **CAL** or **FUNC** mode has been entered you can step through the functions, by pressing and releasing the **F** push button, until the required function is reached. Changes to functions are made by pressing the or push button (in some cases both simultaneously) when the required function is reached. See the flow chart example on the following page.

Entering **CAL** Mode



1. Remove power from the instrument. Hold in the **F** button and reapply power. The display will indicate **CAL** as part of the "wake up messages" when the **CAL** message is seen you can release the button.



2. When the "wake up" messages have finished and the display has settled down to its normal reading press, then release the **F** button.



3. Within 2 seconds of releasing the **F** button press, then release the **▲** and **▼** buttons together. The display will now indicate **FUNC** followed by the first function.

Note: If step 1 above has been completed then the instrument will remain in this **CAL** mode state until power is removed. i.e. there is no need to repeat step 1 when accessing function unless power has been removed.

Entering **FUNC** Mode

No special power up procedure is required to enter **FUNC** mode.

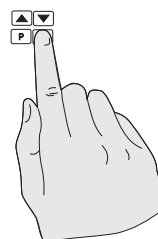

1. When the "wake up" messages have finished and the display has settled down to its normal reading press, then release the **F** button.



2. Within 2 seconds of releasing the **F** button press, then release the **▲** and **▼** buttons together. The display will now indicate **FUNC** followed by the first function.

Example: Entering **FUNC** mode to change alarm 1 high function **ALH** from **OFF** to **100**

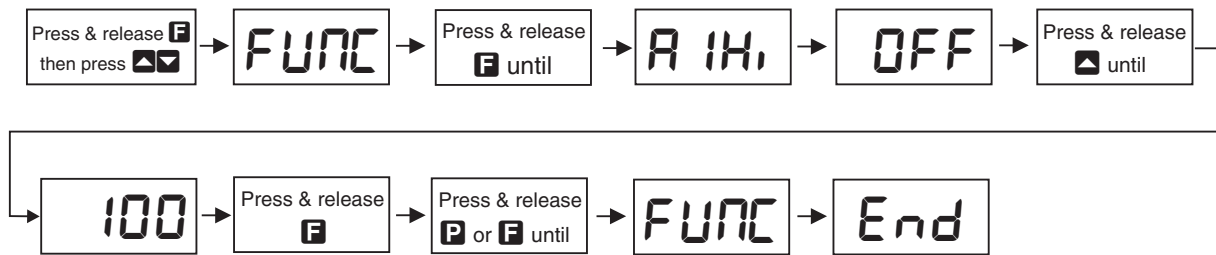

Example: Entering **CAL** mode to change decimal point function **dCPLt** from **0** to **0.02**

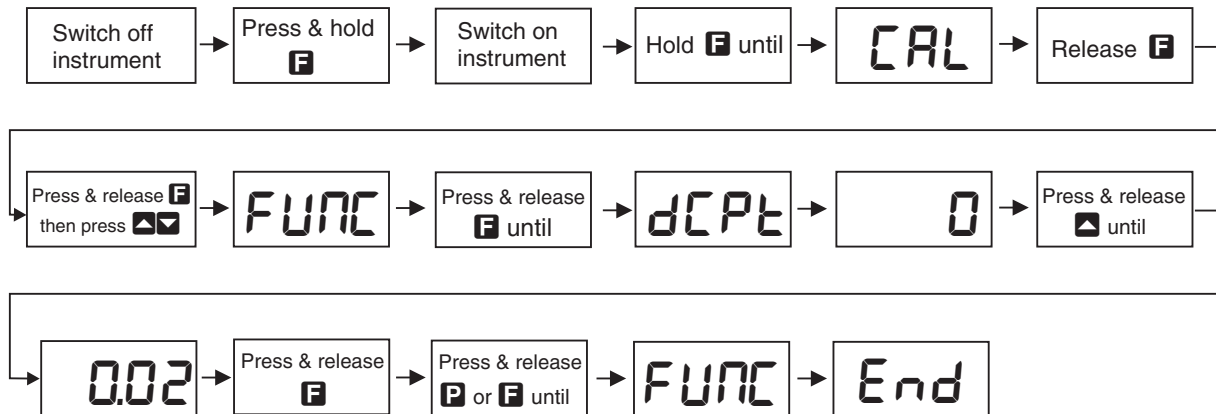

Easy alarm relay adjustment access facility

The display has an easy alarm access facility which allows access to the alarm setpoints simply by pressing the **F** button at the front of the instrument. The first setpoint will then appear and changes to this setpoint may be made to this setpoint via the **▲** or **▼** buttons. Press the **F** button to accept any changes or to move on to the next setpoint. Note: this easy access also functions in the same manner for the PI control setpoint (relay and/or analog PI output) if PI control is available. The instrument must be set in the manner described below to allow the easy access facility to work:

1. A remote input function such as **FNIP** function must be set to **SPAC** or the **ACCS** function must be set to **EASY**.
2. At least one alarm must have a setpoint, nothing will happen if all the alarm setpoints are set to **OFF**.
3. The **SPAC** function must be set to allow access to the relays required e.g. if set to **A1-2** then the easy access will work only with alarm relays 1 and 2 even if more relays are fitted.
4. The instrument must be in normal measure mode i.e. if the instrument is powered up so that it is in **CAL** mode then the easy access will not function. If in doubt remove power from the instrument, wait for a few seconds then apply power again.
5. If the easy access facility is used then the only way to view or alter any other function settings is to power up via **CAL** mode i.e. there is no entry to **FUNC** mode functions unless the instrument is powered up in **CAL** mode.

Explanation of Functions

5.1 Alarm relay low setpoint

Display: $RxLo$
Range: Any display value or **OFF**
Default Value: **OFF**

Displays and sets the low setpoint value for the designated alarm relay x . Note x will be replaced by the relay number when displayed e.g. $R1Lo$ for relay 1. Use this low setpoint function if a relay operation is required when the display value becomes equal to or less than the low setpoint value. To set a low alarm value go to the $RxLo$ function and use the \blacktriangle or \blacktriangledown push buttons to set the value required then press **F** to accept this value. The low alarm setpoint may be disabled by pressing the \blacktriangle and \blacktriangledown push buttons simultaneously. When the alarm is disabled the display will indicate **OFF**. If the relay is allocated both a low and high setpoint then the relay will activate when the value displayed moves outside the band set by the low and high setpoints. The value at which the relay will reset is controlled by the $RxHy$ function.

Example:

If $R1Lo$ is set to **10** then relay 1 will activate when the display value is 10 or less.

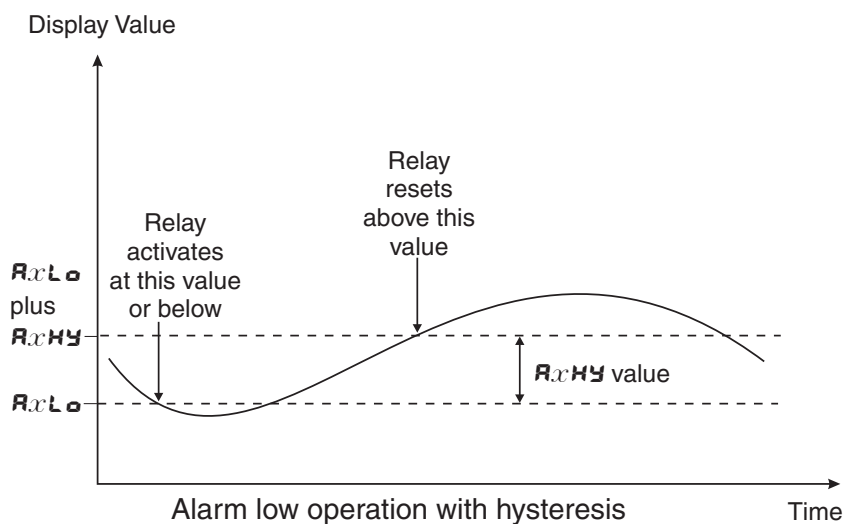

5.2 Alarm relay high setpoint

Display: RxH
Range: Any display value or **OFF**
Default Value: **OFF**

Displays and sets the high setpoint value for the designated alarm relay x . Note x will be replaced by the relay number when displayed e.g. $R1H$ for relay 1. Use this high setpoint function if a relay operation is required when the display value becomes equal to or more than the low setpoint value. To set a high alarm value go to the RxH function and use the \blacktriangle or \blacktriangledown push buttons to set the value required then press **F** to accept this value. The high alarm setpoint may be disabled by pressing the \blacktriangle and \blacktriangledown push buttons simultaneously. When the alarm is disabled the display

will indicate **OFF**. If the relay is allocated both a low and high setpoint then the relay will activate when the value displayed moves outside the band set by the low and high setpoints. The value at which the relay will reset is controlled by the **RxHY** function.

Example:

If **R1H** is set to **100** then relay 1 will activate when the display value is **100** or higher.

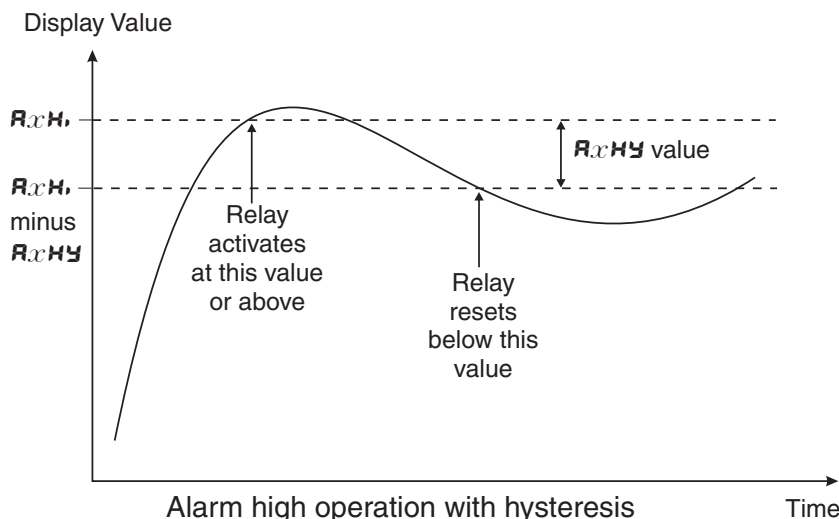

5.3 Alarm relay hysteresis (deadband)

Display: **RxHY**
Range: **0 to 9999**
Default Value: **10**

Displays and sets the alarm relay hysteresis limit for the designated relay *x*. Note *x* will be replaced by the relay number when displayed e.g. **R1HY** for relay 1. To set a relay hysteresis value go to the **RxHY** function and use the **▲** or **▼** push buttons to set the value required then press **F** to accept this value. The hysteresis value is common to both high and low setpoint values. The hysteresis value may be used to prevent too frequent operation of the relay when the measured value is rising and falling around setpoint value. e.g. if **R1HY** is set to zero the alarm will activate when the display value reaches the alarm setpoint (for high alarm) and will reset when the display value falls below the setpoint, this can result in repeated on/off switching of the relay at around the setpoint value.

The hysteresis setting operates as follows: In the high alarm mode, once the alarm is activated the input must fall below the setpoint value minus the hysteresis value to reset the alarm. e.g. if **R1H** is to **50.0** and **R1HY** is set to **3.0** then the setpoint output relay will activate once the display value goes to **50.0** or above and will reset when the display value goes below **47.0** i.e. at **46.9** or below. In the low alarm mode, once the alarm is activated the input must rise above the setpoint value plus the hysteresis value to reset the alarm. e.g. if **R1Lo** is to **20.0** and **R1HY** is set to **10.0** then the alarm output relay will activate when the display value falls to **20.0** or below and will reset when the display value goes above **30.0** i.e. at **30.1** or above. The hysteresis units are expressed in displayed engineering units.

Example: If **R1H** is set to **100** and **R1HY** is set to **10** then relay 1 will activate when the display value is **100** or higher and will reset at a display value of **89** or lower.

5.4 Alarm relay trip time

Display: **Ax.t.t**
Range: **0** to **9999**
Default Value: **0**

Displays and sets the alarm trip time in seconds. The trip time is common for both alarm high and low setpoint values. The trip time provides a time delay before the alarm relay will activate when an alarm condition is present. The alarm condition must be present continuously for the whole trip time period before the alarm will activate. If the input moves out of alarm condition during this period the timer will reset and the full time delay will be restored. This trip time delay is useful for preventing an alarm trip due to short non critical deviations from setpoint. The trip time is selectable over **0** to **9999** seconds. To set a trip time value go to the **Ax.t.t** function and use the **▲** or **▼** push buttons to set the value required then press **F** to accept this value.

Example: If **A 1.t.t** is set to **5** seconds then the display must indicate an alarm value for a full 5 seconds before relay 1 will activate.

5.5 Alarm relay reset time

Display: **Ax.r.t**
Range: **0** to **9999**
Default Value: **0**

Displays and sets the alarm reset delay time in seconds. The reset time is common for both alarm high and low setpoint values. With the alarm condition is removed the alarm relay will stay in its alarm condition for the time selected as the reset time. If the input moves back into alarm condition during this period the timer will reset and the full time delay will be restored. The reset time is selectable over **0** to **9999** seconds. To set a reset time value go to the **Ax.r.t** function and use the **▲** or **▼** push buttons to set the value required then press **F** to accept this value.

Example: If **A 1.r.t** is set to **10** seconds then the resetting of alarm relay 1 will be delayed by 10 seconds.

5.6 Alarm relay normally open/closed

Display: **Ax.n.o** or **Ax.n.c**
Range: **Ax.n.o** or **Ax.n.c**
Default Value: **Ax.n.o**

Displays and sets the setpoint alarm relay *x* action to normally open (de-energised) or normally closed (energised), when no alarm condition is present. Since the relay will always open when power is removed a normally closed alarm is often used to provide a power failure alarm indication. To set the alarm relay for normally open or closed go to the **Ax.n.o** or **Ax.n.c** function and use the **▲** or **▼** push buttons to set the required operation then press **F** to accept this selection. **Example:** If set to **A 1.n.o** alarm relay 1 will be open circuit when the display is outside alarm condition and will be closed (short circuit across terminals) when the display is in alarm condition.

5.7 Alarm relay setpoint or trailing operation

Display: **$AxSP$** or **$Ax\pm i$** etc.

Range: **$AxSP$** or **$Ax\pm i$** etc.

Default Value: **$AxSP$**

Relay operation independent setpoint or trailing setpoint, this function will not be seen unless extra optional relays are fitted. Each alarm, except relay 1, may be programmed to operate with an independent setpoint value or may be linked to operate at a fixed difference to another relay setpoint, known as trailing operation. The operation is as follows:

Alarm 1 (**A1**) is always independent. Alarm 2 (**A2**) may be independent or may be linked to Alarm 1. Alarm 3 (**A3**) may be independent or may be linked to Alarm 1 or Alarm 2. Alarm 4 (**A4**) may be independent or may be linked to Alarm 1, Alarm 2 or Alarm 3. The operation of each alarm is selectable by selecting, for example, (Alarm 4) **A4.SP** = Alarm 4 normal setpoint or **A4.±1** = Alarm 4 trailing Alarm 1 or **A4.±2** = Alarm 4 trailing Alarm 2 or **A4.±3** = Alarm 4 trailing Alarm 3. For trailing set points the setpoint value is entered as the difference from the setpoint being trailed. If the trailing setpoint is to operate ahead of the prime setpoint then the value is entered as a positive number and if operating behind the prime setpoint then the value is entered as a negative number.

Example: With Alarm 2 set to trail alarm 1, if **A1H** is set to **1000** and **A2H** is set to **50** then Alarm 1 will activate at **1000** and alarm 2 will activate at **1050** (i.e. 1000 + 50). If Alarm 2 had been set at **-50** then alarm 2 would activate at **950** (i.e. 1000 - 50).

5.8 Display brightness

Display: **br9t**

Range: **1** to **15**

Default Value: **15**

Displays and sets the digital display brightness. The display brightness is selectable from **1** to **15**, where **1** = lowest intensity and **15** = highest intensity. This function is useful for improving the display readability in dark areas or to reduce the power consumption of the instrument. See also the **dull** function. To set brightness level go to the **br9t** function and use the **▲** or **▼** push buttons to set the value required then press **▣** to accept this value.

5.9 Display remote brightness switching

Display: **dull**

Range: **0** to **15**

Default Value: **1**

Displays and sets the level for remote input brightness switching, see **r.inp** function. When a remote input is set to **dull** the remote input can be used to switch between the display brightness level set by the **br9t** function 5.8 and the display brightness set by the **dull** function. The display dull level is selectable from **0** to **15**, where **0** = lowest intensity and **15** = highest intensity. This function is useful in reducing glare when the display needs to be viewed in both light and

dark ambient light levels. To set dull level go to the **dULL** function and use the ▲ or ▼ push buttons to set the value required then press **F** to accept this value. The **d.oFF SECS** function (automatic display blanking or dulling) will also cause the **dULL** function to appear if the **d.oFF SECS** function is enabled i.e. set to any value other than **0**.

Example:

With **dULL** set to **4** and **brgt** set to **15** and the **FNOP** function set to **dULL** the display brightness will change from the **15** level to **4** when a switch connected to the remote input terminals is activated.

5.10 Auto display dimming timer

Display: **d.oFF SECS**

Range: **0** to **9999**

Default Value: **0**

This function allows a time to be set after which the display brightness (set by the **brgt** function) will automatically be set to the level set at the **dULL** function. The auto dimming feature can be used to reduce power consumption. The function can be set to any value between **0** and **9999** seconds. A setting of **0** disables the auto dimming. The display brightness can be restored by pressing any of the instruments front push buttons. The display brightness will also be restored whilst one or more alarm relays is activated.

5.11 Alarm relay free fall

Display: **Rx FFE**

Range: Any display value

Default Value: **0**

Free fall alarm value - the alarm free fall value is used to provide an offset to the alarm operation. This value can be set anywhere within the measuring range of the instrument and will operate in engineering units e.g. kilograms, tonnes etc. In most applications this function will be used to force the alarm to operate at a given measured quantity prior to the actual alarm relay target weight setting. See also the **FREE ACCS** function 5.27. **Example:**

In a filling application the target weight is 40.0 kg but it is found that due to “in flight” or “free fall” of product the target is consistently 0.5kg over weight. If **R1H** is set to **40.0** and **R1FFEE** is set to **0.5** then relay 1 will activate when the display value reaches **39.5**. With 0.5kg of “free fall” this should ensure that the target weight of 40.0kg is reached.

5.12 Analog output option low value

Display: **FEE _**

Range: Any display value

Default Value: **0**

Seen only when analog retransmission option fitted. Refer to the separate “RM4 Din Rail Meter

Optional Output Addendum” booklet supplied when this option is fitted for wiring details and link settings. Displays and sets the analog retransmission (4–20mA, 0–1V or 0–10V, link selectable) output low value (4mA or 0V) in displayed engineering units. To set the analog output low value go to the **FEC-** function and use the **▲** or **▼** push buttons to set the required value then press **F** to accept this selection.

Example:

If it is required to retransmit 4mA when the display indicates **0** then select **0** in this function using the **▲** or **▼** button.

5.13 Analog output option high value

Display: **FEC~**
Range: Any display value
Default Value: **1000**

Seen only when analog retransmission option fitted. Refer to the separate “RM4 Din Rail Meter Optional Output Addendum” booklet supplied when this option is fitted for wiring details and link settings. Displays and sets the analog retransmission (4–20mA, 0–1V or 0–10V, link selectable) output high display value (20mA, 1V or 10V) in displayed engineering units. To set the analog output high value go to the **FEC~** function and use the **▲** or **▼** push buttons to set the required value then press **F** to accept this selection.

Example:

If it is required to retransmit 20mA when the display indicates **50** then select **50** in this function using the **▲** or **▼** button.

5.14 Preset value

Display: **P.SET**
Range: Any display value
Default Value: **0**

A preset value can be entered at this function. If a remote input (**F.I NP** function) or **P** button (**P.but** function) is programmed to **P.SET** then operation of the remote input or **P** button will cause the display to change to the preset value. Any change in input from this point will cause a variation above or below the preset value. To set preset value go to the **P.SET** function and use the **▲** or **▼** push buttons to set the value required then press **F** to accept this value. **Example:** With a display showing a value of **50** at a given input if the **P.SET** function is set to **70** and the remote function is set to **P.SET** then once the remote input is activated the same input will now have a display value of **70**.

5.15 Calibration number

Display: **CL.no**
Range: **CAL.1** or **CAL.2**
Default Value: **CAL.1**

Cell or channel number selection - selects one of the two possible calibration settings (**CAL.1** or **CAL.2**). This function allows the instrument to be calibrated to two different load cells and hold the calibration values in memory. Alternatively two different calibration scaling values may be entered for a single cell. The user may select the load cell to be used via this **CL.no** function or alternatively via the **P** button (if display has a **P** button, and **Pbut** function 5.23 is set to **CAL.5**) or via a remote input (see **CAL.5** function in section 5.22). To scale any of these independent calibration memories you may use any of the methods described in the Chapter 6. Simply select the required cell number then scale using whichever calibration method best suits the application. If a remote input or **P** button is used to select the channel then do not use the **CL.no** function to select the channel i.e. only use one method of selecting the channel. In addition to different scaling the two channels can be set to operate from different decimal point (**dCPE**), sample rate (**FRE**), mV/V range (**RNGE**), lineariser points (**L.nPTS**, low and high overrange (**Lo di SP** and **Hi 9H di SP**), display warning type (**di SP**) and zero range **ZERO RNGE** settings. If using this function in conjunction with the remote inputs or **P** button functions then the peak hold, display hold, peak and valley memory, zero, remote input calibrate, and serial print output functions will operate individually for each channel, the tare command will tare both channels simultaneously. Other remote input and **P** button functions are not intended for use with the channel selection function.

5.16 Display rounding

Display: **drnd**
Range: **1** to **5000**
Default Value: **1**

Displays and sets the display rounding value. This value may be set to 1 - 5000 displayed units. Display rounding is useful for reducing the instrument resolution without loss of accuracy in applications where it is undesirable to display to a fine tolerance. To set the display rounding value go to the **drnd** function and use the **▲** or **▼** push buttons to set the required value then press **F** to accept this selection.

Example:

If set to **10** the display values will change in multiples of 10 only i.e. display moves from **10** to **20** to **30** etc.

5.17 Decimal point

Display: **dCPE**
Range: **0, 0.1** etc.
Default Value: **0**

Displays and sets the decimal point. By pressing the **▲** or **▼** pushbutton at the **dCPE** function the decimal point position may be set. The display will indicate as follows: **0** (no decimal point), **0.1** (1 decimal place), **0.02** (2 decimal places), **0.003** (3 decimal places) and **0.0004** for display with more than 4 digits. Note if the decimal point is altered the display will need to be recalibrated and alarm etc. settings checked.

5.18 Digital filter

Display: **FLtr**
Range: **0** to **8**
Default Value: **2**

Displays and sets the digital filter value. Digital filtering uses a weighted average method of determining the display value and is used for reducing display value variation due to short term interference. The digital filter range is selectable from **0** to **8**, where **0** = none and **8** = most filtering. Use **▲** or **▼** at the **FLtr** function to alter the filter level if required. Note that the higher the filter setting the longer the display may take to reach its final value when the input is changed, similarly the relay operation and any output options will be slowed down when the filter setting is increased. To set the digital filter value go to the **FLtr** function and use the **▲** or **▼** push buttons to set the required value then press **F** to accept this selection.

5.19 Analog output PI control

Display: **rEc ctrl**
Range: **on** or **OFF**
Default Value: **OFF**

Analog output mode - seen only when analog output option is fitted. This function allows selection of **on** or **OFF** for PI control analog output. If set to **OFF** the analog output operates as a retransmission output and uses the functions described in this chapter. If set to **on** the analog output operates as a PI control output.

When this function is set to **on** the following associated functions will appear: **C.SET**, **C.SPn**, **C-P9**, **C-Po**, **C.I 9**, **C.L.H**, **C.L.L** and **FEC SPAC**.

Refer to the separate "RM4 DIN Rail Meter Optional Output Addendum" booklet for description of the analog PI control functions.

5.20 Sample rate

Display: **FRtE**
Range: **5 . 10 . 15 . 20 . 30 . 40 . 50 . 60 . 80** or **100**
Default Value: **10**

Displays and sets the input sample rate from 5 to 100 samples per second. Note: the display updates approx. 4 times per second. The faster sample rates can be utilised in features such as peak hold, peak/valley memory, analog or digital retransmission and serial communications.

5.21 mV/V input range

Display: **FRGE**
Range: **0.5 . 1.0 . 2.5 . 5.0 . 10 . 25 . 50** or **100**
Default Value: **2.5**

Displays and sets the mV/V (milli Volt output per Volt of excitation) range to suit the transducer useable range. For example a transducer with 2mV/V output will have a theoretical output from 0mV at no load to 20mV at full specified load if 10V excitation is used. Check the transducer label or transducer calibration sheet or brochure for mV/V specification. Choose the value equal to or the next higher value to the mV/V output of the transducer. This selection sets the input range for the A/D converter. If too low a range is selected a “- - - -” error message may be seen on the display when a load is applied. If too high a range is selected the full resolution capability will not be used and problems with calibration can result - see “Error messages” section 5.50.

5.22 Remote input one function

Display: **FRNP**
Range: **NONE . P.HLd . d.HLd . Hi . Lo . Hi . Lo . tARF . 2EFO . SP.Ac . No.Ac .**
CAL.S . P.SET . i . CAL . betch . CAL . or **dULL**
Default Value: **NONE**

Remote input function - When these remote input terminals are short circuited, via a switch, relay, keyswitch etc. the instrument will perform the selected remote input function. A message will flash to indicate which function has been selected when the remote input pins are short circuited. The remote input functions are as follows:

NONE - no remote function required i.e. activating the remote input has no effect.

P.HLd - peak hold. The display will show the peak value (highest positive value) only whilst the remote input terminals are short circuited i.e. the display value can rise but not fall whilst the input terminals are short circuited. The message **P.HLd** will appear briefly every 8 seconds whilst the input terminals are short circuited to indicate that the peak hold function is active.

d.HLd - display hold. The display value will be held whilst the remote input terminals are short circuited. The message **d.HLd** will appear briefly every 8 seconds whilst the input terminals are short circuited to indicate that the display hold function is active.

H_i - peak memory. The peak value stored in memory will be displayed if the remote input terminals are short circuited, if the short circuit is momentary then the display will return to normal measurement after 20 seconds. If the short circuit is held for 2 to 3 seconds or the power is removed from the instrument then the memory will be reset.

L_o - valley memory. The minimum value stored in memory will be displayed. Otherwise operates in the same manner as the **H_i** function described above.

H_i, L_o - toggle between **H_i** and **L_o** displays. This function allows the remote input to be used to toggle between peak and valley memory displays. The first operation of the remote input will cause the peak memory value to be displayed, the next operation will give a valley memory display. **PH_i** or **PL_o** will flash before each display to give an indication of display type.

TAPE - display tare. Short circuiting the remote input pins momentarily will allow toggling between nett and gross values (shown as **NETT** and **GROSS**). If the remote input is short circuited for approx. 2 seconds the display will be tared and will show zero. The tare will be lost if power is removed.

ZERO - display zero. Zeroes the display in same manner as the tare function except that the zero is not lost when power is removed and the display will zero as soon as the remote input is shorted. When the **ZERO** operation is used the gross value cannot be recalled and the input at the time of the **ZERO** operation will become the new zero point.

SP.Ac - setpoint access only. This blocks access to any functions except the alarm setpoint functions unless the remote input pins are short circuited or entry is made via **CAL** mode or if the **ACCS** function is set to **ALL**.

No.Ac - no access. This blocks access to all functions unless the remote input pins are short circuited or entry is made via **CAL** mode or if the **ACCS** function is set to **ALL**.

CAL.S - calibration select. The remote input can be used to select between calibration scaling values. Two sets of calibration scalings can be entered in the RM4, one set with the remote input terminals open circuit and another set with the remote input terminals short circuit to ground. The remote input can then be used to switch between one set and the other. This allows two different load cells to be connected with a remote input being used to select the correct scaling for each or the same load cell could be used and the remote input used to toggle between different display units e.g. between Newtons and kilograms. Note: Alarm settings will not change when changing between calibrations scales. Only one set of alarm functions can be made and the alarm relay will operate from those set values no matter which calibration scale is being viewed at the time. The **dCPE**, **FAEE**, **FA9E**, **L_i n PLS**, **L_o di SP**, **Hi 9H di SP**, **di SP**, and **ZERO FA9E** functions can be individually set for each channel. If **P.SET** is used only one preset value can be used but only the channel displayed at the time is affected. Note; using different **dCPE** settings between channels will affect the preset and alarm setpoint values e.g. a preset of **25** on a channel with **dCPE = 0** will become **2.5** on a channel with **dCPE = 0.1**. Note: the **CL.no** function can also be used to perform the same calibration select function as the **CAL.S** setting. Use only one of these methods to change selection as they will counteract each other if both are used.

P.SET - preset value. The remote input can be used to force the display to the preset value, this preset value is set at the **P.SET** function.

i.CAL - Initiate auto calibration - not available on all software versions - this function allows the user to select when an auto calibration takes place rather than relying on the instruments

normal internal calibration which may cause the output to pause. Closing the external input will cause an internal calibration to take place. If the input is held closed then an internal calibration will take place periodically.

btch - the batch function does not affect the display value when operated. It does, however affect the retransmission and alarm functions, see Chapter 7 for a full description.

CAL - Calibration, when set to **CAL** the remote input can be used to perform a calibration. See Chapter 6 for details.

dull - display brightness control. The remote input can be used to change the display brightness. When this mode is selected the display brightness can be switched, via the remote input terminals, between the brightness level set at the **brgt** function and the brightness level set at the **dull** function.

5.23 **P** button function

Display: **Pbut**
Range: **NONE .H. .Lo.H. Lo. tAFE .ZERO .CAL.S .P.SET** or **btch**
Default Value: **NONE**

P button function - the **P** button may be set to operate some of functions also available via the remote input, see **F.I NP** 5.22 for a description of these functions. If both the remote input and **P** button function are operated simultaneously the **P** button will override the remote input.

5.24 Access mode

Display: **ACCS**
Range: **OFF .EASY .NONE** or **ALL**
Default Value: **OFF**

Access mode - the access mode function **ACCS** has four possible settings namely **OFF .EASY . NONE** and **ALL**. If set to **OFF** the mode function has no effect on alarm relay operation. If set to **EASY** the “easy alarm access” mode will be activated. Refer to “Easy alarm relay adjustment access facility” page 14. If set to **NONE** there will be no access to any functions via **FUNC** mode, entry via **CAL** mode must be made to gain access to alarm and calibration functions. If set to **ALL** then access to all functions, including calibration functions, can be gained via **FUNC** mode.

5.25 Setpoint access mode

Display: **SPAC**
Range: **A 1 .A 1-2** etc.
Default Value: **A 1**

Setpoint access - seen only if more than 1 relay fitted. Sets the access via **FUNC** mode and “easy alarm access” mode to the alarm relay setpoints. The following choices are available:

A 1 - Allows setpoint access to alarm 1 only.

A 1-2 - Allows setpoint access to alarms 1 and 2 only.

A 1-3 - Allows setpoint access to alarms 1, 2 and 3 etc. up to the maximum number of relays fitted.

A remote input function (**R.I NP**) must be set to **SP.AC** for this function to operate. Note: Only the setpoints which have been given a value will be accessible e.g. if **A 1H** is set to **OFF** then there will be no access to the **A 1H** function when **SP.AC** is used.

5.26 Lineariser points

Display: **LINPTS**
Range: **2.3.4** or **5**
Default Value: **2**

Lineariser points - see section 6.1. Displays and sets the number of calibration scaling points to be used.

5.27 Easy access for alarm relay free fall

Display: **FREE ACCS**
Range: **on** or **OFF**
Default Value: **OFF**

Easy access to free fall alarm values - When set to **on** allows the free fall alarm values to be accessed via “Easy access” mode, see section 5.24 for a description. If more than one relay is fitted to the instrument only the relays selected at the **SP.AC** function above will have easy access. If set to **OFF** the free fall values are not available in “Easy access” and any changes to the values must be done at the **Ax FREE** function.

5.28 First live calibration point

Display: **CAL 1**
Range: Any display value
Default Value: n/a

Calibration scaling first point - see section 6.1.

5.29 Second live calibration point

Display: **CAL 2**
Range: Any display value
Default Value: n/a

Calibration scaling second point - see section 6.1.

5.30 Third live calibration point

Display: **CAL3**
Range: Any display value
Default Value: n/a

Calibration scaling third point, seen only when **LINPTS** is set to **3.4** or **5** - see section 6.1.

5.31 Fourth live calibration point

Display: **CAL4**
Range: Any display value
Default Value: n/a

Calibration scaling fourth point, seen only when **LINPTS** is set to **4** or **5** - see section 6.1.

5.32 Fifth live calibration point

Display: **CAL5**
Range: Any display value
Default Value: n/a

Calibration scaling fifth point, seen only when **LINPTS** is set to **5** - see section 6.1.

5.33 mV/V entry scaling method

Display: **ECAL**
Range: **-19.999 to 32.000**
Default Value: **1.000**

mV/V scaling, seen only when **LINPTS** is set to **2** - see section 6.2

5.34 Calibration offset

Display: **CAL OFFS**
Range: Any display value
Default Value: n/a

Calibration offset - See section 6.3.

5.35 Set zero

Display: **SEt ZER0**
Range: Any display value
Default Value: n/a

Set zero point - see section 6.5.

5.36 Zero range

Display: **ZER0 RANG**
Range: Any display value or **OFF**
Default Value: **OFF**

Zero range limit value - see section 6.6.

5.37 Zero reference point for **ZER0 RANG** operation

Display: **CAL ZER0**
Range: n/a
Default Value: n/a

Zero point calibration for **ZER0 RANG** function - see section 6.7.

5.38 Auto zero range

Display: **Aut0 ZER0**
Range: **0** to **100**
Default Value: **0**

The display can be set to automatically zero its reading if the display is within the range set by the **Aut0 ZER0** function for the set number of samples, see **A.2. cnt** 5.39. For example if the auto zero is set to **10** then the instrument will re-zero itself whenever the display is within **10** units of zero for the set number of samples i.e. between **-10** and **10**. Setting auto zero to **0** will disable the function and the instrument will not zero automatically. The time taken to auto zero depends upon the sample rate and the sample count **A.2. cnt** setting.

5.39 Auto zero sample count

Display: **A.2. cnt**
Range: **10** to **100**
Default Value: **10**

Displays and sets the number of samples to be taken for the auto zero function **Aut0 ZER0**. For

example if set to **50** then if the display is within the auto zero setting (e.g. **10**) for 50 samples then the instrument will automatically zero.

5.40 Alarm relay operation mode

Display: **A 1.R2** etc.

Range: **L, UE, TARE, btch, P.HLd, d.HLd, H, Lo** or **d: SP**

Default Value: **L, UE**

Alarm relay operation mode for relays 1, 2 etc. The following choices are available for alarm operation mode:

L, UE - live input mode. The alarm relay operation will always follow the electrical input at that time irrespective of the 7 segment display value. e.g. assume the remote input is set to **TARE** and **A 1H** is set to **100**. If the instrument is tared at a display reading of **30** then the alarm will now activate at a display reading of **70**. Note that the **L, UE** mode does not follow the electrical input if a remote input or **P** button **ZERO** operation has been undertaken. This is due to the fact that the **ZERO** operation shifts the display calibration.

TARE - tare mode. The alarm relay operation will follow the tare function. e.g. in the example above (**L, UE**) if **A 1** is set to **TARE** then the alarm would activate at a display reading of **100** (the setpoint value) rather than **70**.

btch - batch mode. The alarm relay operation will follow the batch mode operation when the **r: NP, r: N2, r: N3** or **Pbut** function is set to **btch**. See section 5.22.

P.HLd - peak hold mode. When **P.HLd** is selected and the remote input is set to peak hold (**P.HLd**) then once the peak display goes above any alarm high setpoint the alarm relay will activate and will not de-activate until the peak hold is released and the display value falls below the setpoint value.

d.HLd - display hold mode. When **d.HLd** is selected and the remote input is set to display hold (**d.HLd**) then the alarm relay will be held in its present state (activated or de-activated) until the display hold is released and the display is free to change.

H, - peak (max.) memory mode. When **H,** is selected and the remote input is set to peak memory (**H,**) then the alarm will be activated if the peak memory value is above the high setpoint value. The alarm will not de-activate until the memory is reset.

Lo - valley (min.) memory mode. When **Lo** is selected and the remote input is set to valley memory (**Lo**) then the alarm relay will be activated if the valley memory value is below the low setpoint value. The alarm will not de-activate until the memory is reset.

d: SP - display mode. When **d: SP** is selected the alarms will operate purely on the display value at the time i.e. if the display is showing above high setpoint or below the low setpoint value then the alarm relay will activate.

5.41 Analog output operation mode

Display: **rEC**
Range: **L, UE, tARE, btch, P.HLd, d.HLd, H, Lo** or **d! SP**
Default Value: **L, UE**

This section describes the operation modes available for the retransmission options **rEC** (analog retransmission) operation mode. The following choices are available:

L, UE - live input mode. The retransmission will follow the electrical input and will not necessarily follow the 7 segment display. For example if the remote input is set for peak hold operation then when the remote input is closed the 7 segment display will only show the peak value but the retransmission will be free to change to follow the electrical input.

tARE - tare mode. The retransmission value will tare (fall to zero) along with 7 segment display when the remote input tare function is operated. If the remote input toggles the 7 segment display to show gross (**gROS**) then the 7 segment display will change to show the gross value but the retransmission will not respond (see **L, UE** for alternative operation).

btch - batch mode. The output operation will follow the batch mode operation when the **r! RP**, or **Pbut** function is set to **btch**. e.g. if **rEC-** is set to **0** and **rEC+** is set to **100** and the instrument is given a remote batch (via an external input or the **P** button) when the display shows **30** then after the batch input the display is unaltered but for a 4-20mA retransmission, 4mA will be transmitted at the batched display value of **30** and 20mA will be transmitted for a display value of **130**.

P.HLd - peak hold mode. The 7 segment display and retransmission value will indicate the peak value only whilst the peak value function is operated via a contact closure on the remote input i.e. the 7 segment display and retransmission can rise but not fall whilst the remote input switch is closed. When the remote input switch is opened the retransmission value will remain fixed i.e. it will not rise or fall, although the 7 segment display value will be free to alter. This peak retransmission output can be cleared by closing the remote input switch for another operation or by removing power from the instrument. Note: In this mode the retransmission will show a zero reading until the remote input is operated for the first time after switch on.

d.HLd - display hold mode. The 7 segment display and retransmission value will be held whilst the remote input display hold switch is closed. When the switch is opened the retransmission value will remain fixed at the held value although the 7 segment display value will be free to alter. The held retransmission output can be cleared by closing the remote input switch for another operation or by removing power from the instrument. Note: In this mode the bargraph will show a zero reading until the remote input is operated for the first time after switch on.

H - peak (max.) memory mode. With the peak remote input switch open the retransmission will indicate the peak value in memory i.e. the retransmission output can rise but not fall. The retransmission output can be reset by clearing the memory. The memory may be cleared either by closing the remote input switch for approximately 2 seconds or by removing power to the instrument.



Lo - valley (min.) memory mode. With the valley remote input switch open the retransmission will indicate the valley (min.) value in memory i.e. the retransmission output can fall but not rise. The retransmission output can be reset by clearing the memory. The memory may be cleared either by closing the remote input switch for approximately 2 seconds or by removing power to the

instrument.

d: SP - display mode. The retransmission output will follow whatever value is on the 7 segment display. For example if the remote input is set to **SAFE** then the 7 segment and retransmission output will indicate the tared value and both will also be changed if the remote input toggles the displays between **RETT** and **GFOS**. If the **FEC** or **d90P** function had been set to **SAFE** then the retransmission output would not respond to the **GFOS** toggle.



5.42 Low overrange visual warning limit value

Display: **Lo d: SP**
Range: Any display value or **OFF**
Default Value: **OFF**

Low overrange limit value - the display can be set to show an overrange message if the display value falls below the **Lo d: SP** setting. For example if **Lo d: SP** is set to **50** then once the display reading falls below **50** the message **-or-** will flash on and off or the display value will flash on and off instead of the normal display units (see **d: SP** function 5.44). This message can be used to alert operators to the presence of an input which is below the low limit. If this function is not required it should be set to **OFF** by pressing the  and  buttons simultaneously at this function.

5.43 High overrange visual warning limit value

Display: **Hi 9H d: SP**
Range: Any display value or **OFF**
Default Value: **OFF**

High overrange limit value - the display can be set to show an overrange message if the display value rises above the **Hi 9H d: SP** setting. For example if **Hi 9H d: SP** is set to **1000** then once the display reading rises above **1000** the message **-or-** will flash on and off or the display value will flash on and off instead of the normal display units (see **d: SP** function 5.44). This message can be used to alert operators to the presence of an input which is above the high limit. If this function is not required it should be set to **OFF** by pressing the  and  buttons simultaneously at this function.

5.44 Display visual warning flashing mode

Display: **d: SP**
Range: **FLSH** or **-or-**
Default Value: **FLSH**

Display overrange warning flashing mode - this function is used in conjunction with the **Lo d: SP** and **Hi 9H d: SP** functions. The **d: SP** function can be set to **FLSH** or **-or-**. If the display warning value set at the **Lo d: SP** or **Hi 9H d: SP** function is exceeded and the **d: SP** function is set to **FLSH** then the display value will flash on and off every second as a visual warning. If the

display warning value set at the **Lo di SP** or **Hi GH di SP** function is exceeded and the **di SP** function is set to **-or-** then the **-or-** message will flash on and off once a second as a visual warning. The warning flashes will cease and the normal display value will be seen when the value displayed is higher than the low limit and lower than the high limit.

5.45 Baud rate for optional serial communications

Display: **BAUD RATE**
Range: **300 . 600 . 1200 . 2400 . 4800 . 9600 . 19.2** or **38.4**
Default Value: **9600**

Set baud rate - seen only with serial output option. Refer to the separate “RM4 Din Rail Meter Optional Output Addendum” booklet supplied when optional outputs are fitted. Select from **300 . 600 . 1200 . 2400 . 4800 . 9600 . 19.2** or **38.4** baud.

5.46 Parity for optional serial communications

Display: **Prty**
Range: **NONE . EVEN** or **odd**
Default Value: **NONE**

Set parity - seen only with serial output option. Refer to the separate “RM4 Din Rail Meter Optional Output Addendum” booklet supplied when optional outputs are fitted. Select parity check to either **NONE**, **EVEN** or **odd**.

5.47 Output mode for optional serial communications

Display: **O.Put**
Range: **di SP . Cont . POLL** or **̄.buS**
Default Value: **Cont**

Set serial interface mode - seen only with serial output option. Refer to the separate “RM4 Din Rail Meter Optional Output Addendum” booklet supplied when optional outputs are fitted. . Allows user to select the serial interface operation as follows:

di SP - sends image data from the display without conversion to ASCII.

Cont - sends ASCII form of display data at a rate typically 90% of the sample rate.

POLL - controlled by computer or PLC as host. Host sends command via RS232/485 and instrument responds as requested.

̄.buS - Modbus RTU protocol.

5.48 Instrument address for optional serial communications

Display: **Addr**
Range: **0 to 31**
Default Value: **0**

Set unit address for polled (**POLL**) mode (**0 to 31**) - seen only with serial output option. Refer to the separate “RM4 Din Rail Meter Optional Output Addendum” booklet supplied when optional outputs are fitted. Allows several units to operate on the same RS485 interface reporting on different areas etc. The host computer or PLC may poll each unit in turn supplying the appropriate address. The unit address ranges from 0 to 31 (DEC) but is offset by 32 (DEC) to avoid clashing with ASCII special function characters (such as <STX> and <CR>). Therefore 32 (DEC) or 20 (HEX) is address 0, 42 (DEC) or 2A (HEX) is address 10.

5.49 Returning to normal measure mode

When the calibration has been completed it is advisable to return the instrument to the normal mode (where calibration functions are less likely to be tampered with). To return to normal mode, turn off power to the instrument, wait a few seconds and then restore power.

5.50 Error messages

SPAN Err - calibration span error. Live inputs used at **CAL 1** and **CAL 2** or other live calibration points are too close in value. The change in mV input or load applied to the cell must be at least 10% of the full range or capacity of the cell between live input calibration points. Recalibrate using inputs further apart in value. If you are certain that the inputs are far enough apart but still see the **SPAN Err** message then ignore the message and continue with the calibration. At the end of the calibration check to see if the display calibration is correct and if not recalibrate using the same inputs. If the error message persists check that the output from the load cell has changed sufficiently by measuring the mV output at no load and with the calibration load applied. See also the **Using the INPUT display to test input level** section which follows for an easy method of checking the input level.

CAL Err - This indicates that one of the calibration points has caused an overrange error in the analog to digital converter. Check the mV output from the load cell and check that the **RANGE** function setting is set to the correct range for the load cell used.

ZERO RANGE Err - Zero range error. Caused by an attempt to zero the display outside the allowed range. See **ZERO RANGE** function ref. 6.6.

ADC RANGE Err - This indicates that when an **ECAL / ESCL** method of calibration has been used the mV/V figure entered at the **ECAL** function is greater than the mV/V range entered at the **RANGE** function. The **RANGE** function should be set to be equal the **ECAL** value or to the next available value higher than the **ECAL** value.

LINE Err or **LINE Err** - these error messages indicate that the **LINE** function is set to a value of 3, 4 or 5 i.e. multipoint calibration for linearisation is selected and that an error in the polarity of the input has occurred. When using more than 2 calibration points

it is essential that each input is greater than the previous point by at least 10% of the input range and is greater in the positive direction than the previous point. If a calibration point is seen to be more negative than the previous one the **tbLE Err** will be seen after the calibration for that point is attempted. The **L, n tbLE Err** error message will be seen at power up if there has been such a calibration error and it has not been corrected. If the signal is increasing negatively then check wiring of the load cell/pressure sensor. See also the **Using the I nPt display to test input level** section which follows for an easy method of checking the input level.

Unstable display - if the display is not stable the usual cause is either that the input signal is unstable or that the calibration scaling was incorrectly attempted. Measure the mV input at the Signal + and Signal - terminals to check for stability. If the mV input is stable recalibrate the display. See also the **Using the I nPt display to test input level** section which follows for an easy method of checking the input level.

Display shows “- - - -” - this message indicates that the input signal is higher than the range selected. Check that the **rnGE** function is set to the correct mV/V for the load cell used. If this is set correctly check that the mV input at the Signal + and Signal - terminals is within the range selected. e.g. if **rnGE** is set to **2.5** and the excitation voltage is set to 10V then the input mV signal at the Signal + and Signal - terminals should be no greater than 25mV.

Display shows -or- - this message indicates either that the number is too big to display e.g. above **9999** on a 4 digit display or that the **di SP** function has been set to **-or-** and either the **Lo di SP** or **Hi 9H di SP** limits have been exceeded. You can check if this is the problem by setting the **di SP** function to **FLSH** which will cause the display value rather than the **-or-** message to flash if the limits set have been exceeded. If the **di SP** setting is not the problem then try recalibrating the display. If the **-or-** message is seen during calibration ignore it proceed with the calibration then check the display reading again after calibration. See also the **Using the I nPt display to test input level** section which follows for an easy method of checking the input level.

Display value flashes on and off - this indicates that the **di SP** function ref 5.44 has been set to **FLSH** and either the **Lo di SP** or **Hi 9H di SP** function limits set have been exceeded.

NO ACCS - This display mean that function access has been denied. This will be due to either one of the remote input functions (**r.i nP**, **r.i n2** or **r.i n2**) being set to **No.Ac** or that the **ACCS** function being set to **NONE**. To override the remote input functions and gain access you can either place a short circuit between the appropriate remote input and ground or power up the instrument in **CAL** mode. To override the **ACCS** function you must power up in **CAL** mode.

NO SPAC - This display mean that function access has been denied. This will be due to either one of the remote input functions (**r.i nP**, **r.i n2** or **r.i n3**) being set to **SP.Ac** or the **ACCS** function has being set to **EASY** and all alarm setpoints have been set to **OFF**. To override the remote input functions and gain access you can either place a short circuit between the appropriate remote input and ground or power up the instrument in **CAL** mode. To override the **ACCS** function you must power up in **CAL** mode.

6 Calibration

Unique calibration procedures allow four different methods of calibration scaling to suit various applications. Use only one of these methods to calibrate the display.

Method 1 - (**CAL 1/SCL 1** etc.) - two, three, four or five calibration points are independently set from “live” inputs. The ability to set each point individually is useful where the calibration is being carried out on site and delays are experienced during the calibration procedure (e.g. filling tanks etc.). If two points are used the display will be linear. If more than two points are used the display can be made to follow a linearisation curve. The number of points to be used is set at the function. If more than two points are used it is essential that each point is at a higher input than the previous one.









Method 2 - (**ECAL/ESCL**) - allows entry of the mV/V figure of the load cell being used together with a scaling value i.e. no live input is required to obtain the scaling points. Note that this method is only applicable if two lineariser (**L, n Pts**) points are set.

Method 3 - (**CAL OFSt**) - allows a single point offset to be introduced.

Method 4 - (**Func NP** set to **CAL**) - allows a simple pushbutton calibration from a live input. This method is particularly suited to item counting applications. Note that this method is only applicable if two lineariser (**L, n Pts**) points are set.

6.1 Method 1 - calibration by entering known live input values

Method 1 uses two, three, four or five different live input values to calibrate the instrument.

1. Enter via **CAL** mode, see page ??.
2. Check that the **dCPE** and **Range** functions are set as required.
3. Step through the functions until the display indicates **L, n Pts** and use the  or  pushbutton to select the number of calibration scaling points required.
4. Step through the functions until the display indicates **CAL 1**. Now press, then release, the  and  buttons simultaneously to enter the calibration functions. The display will now indicate **CAL 1** (1st calibration point) followed by a “live” reading. Apply a known input to the instrument of nominally 0% (this value is not critical and may be anywhere within the measuring range of the instrument). For example you could arrange that the load or pressure is zero at this time. When the live reading has stabilised press the **F** button.
5. The display will indicate **SCL 1** (scale 1) followed by the scale value in memory. Now use the  or  button to obtain the required scale value.
6. Press the **F** button, the display will now indicate **CAL End** (indicating that calibration of the first point is complete).
7. The display will now indicate **CAL 2** (2nd calibration point). If you do not wish to enter the second point at this stage then press and release the **F** button until the **Func End** message is seen. If you wish to enter the second point at this stage press the  and  buttons simultaneously.

8. The display will now indicate **CAL 2** (2nd calibration point) followed by a “live” reading. Apply an input greater than that used for **CAL 1** (again this value is not critical, but there needs to be a change of at least 10% of the capacity of the load cell between points).
9. When the reading has stabilised, press the **F** button, the display will now read **SCL 2** (scale 2) followed by the second scale value in memory. Use the **▲** or **▼** button to obtain the required scale value. Press the **F** button, the display will now read **CAL End** (indicating that calibration of the second point is complete).
10. Repeat the process for the remaining calibration points (**CAL 3** etc.). Note if more than 2 points are used it is essential that the higher points are more positive and are at least 10% of full scale higher than the previous points i.e. it is essential that the input is increasing in a positive direction. If an input is more negative than the previous calibration input an error message **BLE Err** will be seen when the calibration attempt is made.

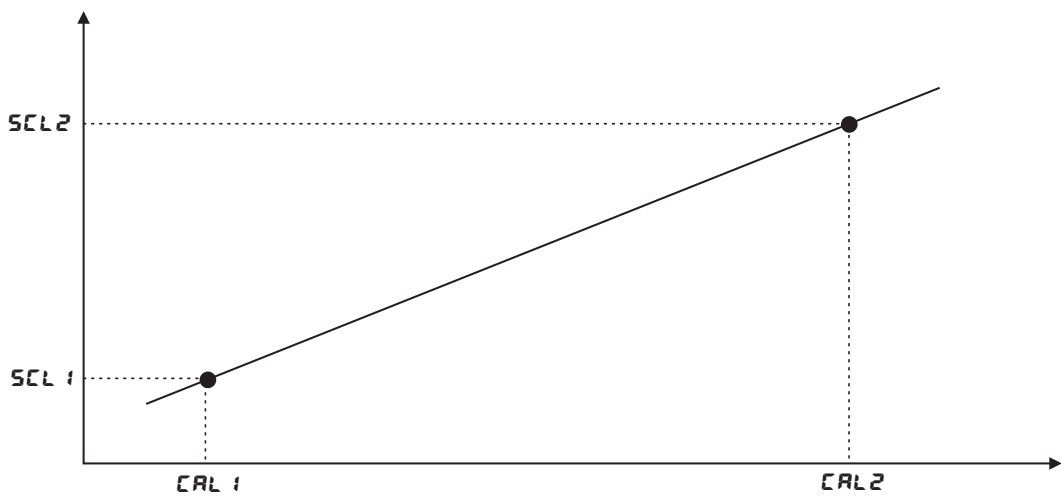

Two scaling points - display is linear

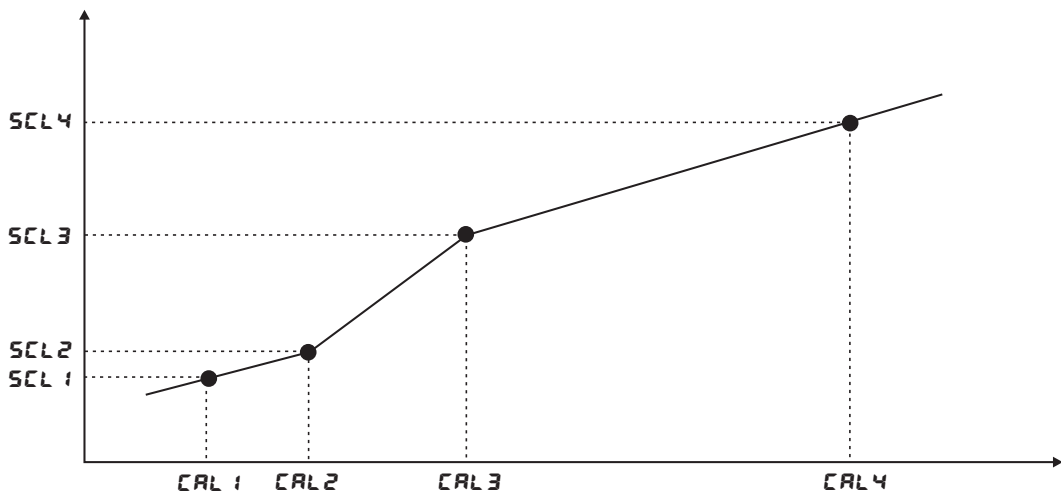

More than two scaling points - linearised display

6.2 Method 2 - mV/V value entry calibration

Note: this method can only be used if the **LOAD PLS** function is set to **2**. This alternative calibration method allows the known mV/V value of the load cell to be entered as the calibration value. The value is entered to 3 decimal places, any number from 32.000 to -19.999 mV/V can be input. If the required value is outside this range then use a convenient available value and alter the **ESCL** value to compensate.

1. Enter via **CAL** mode, see page ??.
2. Check that the **DCPL** and **RNGE** functions are set as required.
3. Step through the functions until the **ECAL** display is seen.
4. Press the **▲** and **▼** buttons simultaneously to get a display of the current mV/V setting. Use **▲** or **▼** to alter this value to the mV/V output of the cell being used.
5. Press and release the **F** button, the display will now show **ESCL** followed by the current scale value.
6. Use **▲** or **▼** to alter this value if required (this value is the reading required at the maximum rated load for the cell e.g. for a 100kg load cell required to display directly in kg set the **ESCL** value to **100** (or **100.0** etc. depending on the decimal point setting).
7. Press then release the **F** button the display will show **ECAL End** and the instrument moves on to the next function (**CAL OFSt**).
8. Once the **ECAL** and values have been entered you must operate the **SEt SEt ZER0** function described below or use the **P** button or remote input **ZER0** function to zero the display with the sensor connected at no load/pressure. This zeroing process will remove the effects of any no load offset outputs present at the sensor. If using the two point calibration method (method 1), as previously described, the mV/V value is automatically calculated and may be viewed at the **ECAL** function. The **ECAL** and **ESCL** values may be recorded and re-entered to re-scale the instrument to the same load cell at a later date.

6.3 Method 3 - offset calibration

CAL OFSt - Calibration offset - the calibration offset is a single point adjustment which can be used to alter the calibration scaling values across the entire measuring range without affecting the calibration slope. This method can be used instead of performing a two point calibration when a constant measurement error is found to exist across the entire range. To perform a calibration offset press the **▲** and **▼** buttons simultaneously at the **CAL OFSt** function. A “live” reading from the input will be seen, make a note of this reading. Press the **F** button, the message **SCLE** will now be seen followed by the last scale value in memory. Use the **▲** or **▼** button to adjust the scale value to the required display value for that input. For example if the “live” input reading was **50** and the required display value for this input was **70** then adjust the **SCLE** value to **70**. Press the **F** button to accept changes or the **P** button to abort the scaling. If the scaling has been accepted the message **OFSt End** should be seen. If the **ZER0 RNGE Err** message is seen refer to the **ZER0 RNGE** and **CAL ZER0** functions.

6.4 Method 4 - remote input calibration

Note: this method can only be used if the function is set to **2**. The remote input calibration method allows simple, live input, calibration suitable for situations requiring frequent calibration such as in item counting by weight applications. In this method of calibration a remote input function (e.g. **FI NP**) is assigned to **CAL**, closure of the remote input then initiates the calibration process. The procedure is as follows:

1. Assign a remote input (e.g. via **FI NP** function) to **CAL**.
2. Assign a different remote input or the **P** button to **ZERO** and zero the display when it is in a no load condition.
3. Place a weight (or known number of items) on the weighing platform then operate the **CAL** remote input i.e. close the switch.
4. The message **SCALE** will appear on the display followed by the previous scale value in memory. Use the **▲** or **▼** button to alter this reading to the value required for this load.
5. Press then release, the **F** button, the message **CAL End** will be seen and the instrument will return to normal measure mode. Note that the **P** button may be used to abort the calibration process once beyond step 3.



6.5 Set zero

Used to set the load cell system to display reading of zero. Most usually used following an **ECAL** method calibration to remove any zero offset. The set zero point is entered when the load cell is installed and in a no load condition or at the load at which the display is required to read zero. To operate the set zero function press, then release, **▲** and **▼** buttons simultaneously at the **SET ZERO** function. The zero point will be retained even if power is removed and has the same effect as the remote input or **P** button **ZERO** operation.

6.6 Zero range function

ZERO RANGE - Zero Range - the zero range function allows a limit value to be set (in engineering units) above which the display will not zero i.e. if a zero operation is attempted via the **P** button, remote input or set zero function when the display value is greater than the zero range setting the display will refuse to zero and give a **ZERO RANGE Err** message (note that the **CAL OFFSET** function is also affected by the **ZERO RANGE** setting). For example if the zero range setting is **10** the instrument will only respond to a zero operation if the display reading at the time is between **-10** and **10**. If the zero range function is not required it can be set to **OFF** by pressing the **▲** and **▼** buttons simultaneously at this function. When switched off the instrument can be zeroed no matter what the display value. Note that the instrument keeps track of the value being zeroed at each operation, when the total amount zeroed from repeated operations becomes greater than the zero range value the instrument will reject the zero operation and a **ZERO RANGE Err** message will be seen. To allow a zero operation beyond this point either the **ZERO RANGE** function value will need to be raised or a new zero reference point introduced via the **CAL ZERO** function. If repeated zero operations are required the **ZERO RANGE** function should be set to **OFF** or alternatively the **SAFE** operation could be considered.

6.7 Zero range zero calibration function

CAL ZERO - Zero range zero calibration - a **CAL ZERO** zero operation can be used to ensure that the display zero and the **ZERO RANGE** reference zero are at the same point after a calibration. After a calibration the **CAL ZERO** operation can also be used to select a zero point other than the display zero as the reference for the **ZERO RANGE** function. For example if the **CAL ZERO** operation is carried out with a display reading of **500** and a **ZERO RANGE** reading of **10** the zero range function will allow the display to zero only if the current display reading is between **490** and **510**. To perform a calibration zero press the  and  buttons simultaneously at the **CAL ZERO** function, a live reading will be seen, press the  button, the message **CAL ZERO End** should now be seen indicating that the instrument has accepted the zero point. Although the display reading will not change as a result of the calibration zero the input value on the display at the time of the operation will be the new zero reference point for the **ZERO RANGE** function.

7 Batching operation

The remote input **FINP** and the **P** button function (**Pbut**) may be programmed to operate in batch (**btch**) mode. Operation of any of these inputs in batch mode will have no effect on the displayed value (i.e. the total load or weight is always visible) but can be made to affect the method in which the setpoint alarm relays and retransmission options operate.

Alarm operation in batch mode

In addition to setting the required remote input or **P** button function to **btch** the alarm mode function for the required alarm operation mode must also be set to **btch**. The alarm operation mode functions are **A1** for alarm 1, **A2** for alarm 2 (if fitted), **A3** for alarm 3 (if fitted) etc.

When in batch mode the selected alarm may be set to operate at a given batch figure i.e. **A1Lo** or **A1H** can be allocated batch values.

Example: Assume that the display is scaled to read in kilograms up to a maximum of 1000kg. **FINP** is set to **btch** and **A1** is also set to **btch**. **A1H** is set to **100**, **A1Lo** is set to **OFF** and **A1HY** is set to **0**. If the display reading is **300** when the remote input is operated then the display will not alter but alarm 1 relay will now activate when the display reading increases by the batch value of **100** i.e. at a value of **400** or above.

The effect on alarm settings for the same example is shown in the table below.

Relay settings with A1HY = 0	Relay deactivates	Relay activates
A1Lo = OFF, A1H = 100	At values below 400	At values above 400 i.e. 300 + the batch value
A1Lo = OFF, A1H = -100	At values below 200	At values above 200
A1Lo = 100, A1H = OFF	At values above 400	At values below 400
A1Lo = -100, A1H = OFF	At values above 200	At values below 200
A1Lo = 50, A1H = 100	At values between 350 and 400	At values below 300 or above 400

The effect of a hysteresis setting (setting **A1HY** to **10** in this example) is shown in the table below.

Relay settings with A1HY = 10	Relay deactivates	Relay activates
A1Lo = OFF, A1H = 100	At values below 390	At values above 400 i.e. 300 + the batch value
A1Lo = OFF, A1H = -100	At values below 190	At values above 200
A1Lo = 100, A1H = OFF	At values above 410	At values below 400
A1Lo = -100, A1H = OFF	At values above 210	At values below 200

Example: Assume that **A1H** is set to **-25.0** and that the instrument is given a remote batch input when the display reads **200.0** i.e. the alarm relay is activated at this stage. The display does not alter when a batch input is applied but alarm 1 will not reset until the display goes below **175.0** (**200** minus **25.0**). i.e. once the batch input is applied the display value must decrease by the alarm value before the alarm will reset.

7.1 Retransmission operation in batch mode

As with the alarm operation the display value does not alter once the batch function has been operated. The retransmission value will, however, will be affected. Functions to set the retransmission to follow the batch operation are **FEC** for analog retransmission , **DRDP** for digital retransmission. For serial retransmission the display must receive a request to operate its remote input function (using the “Reset special function value” command , refer to the separate Optional Output Addendum booklet).

Example

The analog retransmission has been set via the **FEC_L** and **FEC_H** functions to transmit a 4mA signal at a display value of **0** and to transmit a 20mA signal at a display value of **1000**. The **FEC** and **DRDP** functions have been set to **batch**. If the remote input is operated when the display value is **80** then the display will now transmit 4mA at a display value of **80** and will transmit 20mA at a display value of **1080**. The analog retransmission could be input to a PLC or other device for control purposes.

8 Specifications

8.1 Technical specifications

Input:	Ratiometric 4 wire strain gauge.
Input Sensitivity:	85 Ω to more than 2000 Ω
Excitation:	10V or 5V, link selectable
Accuracy:	Up to 0.005% of full scale for alarms and display, depending on sample rate etc., see resolution table which follows. Accuracy for analog retransmission better than 0.05% system accuracy Using ECAL and ESCL calibration method accuracy is 1%
Sample rate:	5 to 100 sample per second, selectable. Note that output options such as serial or analog output will be updated at a slightly lower rate e.g. at 100 samples/sec. the output option will typically update at approximately 90 per second
ADC Resolution:	Up to 22 bits depending on sample rate and mV/V input, see 8.4
Display update:	Up to 4 per second
Conversion Method:	Sigma delta
Microprocessor:	HC68HC11F CMOS
Ambient temperature:	-10 to 60° C
Humidity:	5 to 95% non condensing
Display:	LED 5 digit 7.6mm + alarm annunciator LEDs
Power supply:	AC 240V, 110V 32V or 24V 50/60Hz or DC isolated wide range 12 to 48V. Note: supply type is factory configured.
Power consumption:	AC supply 4 VA max, DC supply typically 150mA at 12VDC and 75mA at 24VDC for RM4 with 350 Ω load, no optional outputs
Output (standard):	2 x relay, Form A, rated 5A resistive. Programmable N.O. or N.C

8.2 Optional outputs

Third relay:	Rated 0.5A resistive 30VAC or DC May be configured as form A or form C if the third relay is the only option fitted
Fourth relay:	Rated 0.5A resistive 30VAC or DC, form A
Analog output:	Isolated 4 to 20mA, 0 to 1V or 0 to 10V link selectable 12 or 16 bit versions available (4-20mA will drive into resistive loads of up to 800 Ω)
Serial communications:	Isolated RS232, RS485 or RS422 (ASCII or Modbus RTU)
DC supply output:	Isolated and regulated 12VDC (50mA max) or 24VDC (25mA max)

Some combinations of optional outputs are available e.g. analog output plus extra relay. Consult supplier for available combinations.

8.3 Physical characteristics

Case size: 44mm(w) x 91mm(h) x 141mm(d)
 Connections: Plug in screw terminals (max. 2.5mm² wire for power and relays, max. 1.5mm² wire for load cell and options)
 Weight: 470 gms basic model, 500 gms with option card

8.4 Resolution table

Effective resolution (bits) for RM4-WT over full scale							
Samples/sec.	mV/V input						
	0.5mV/V	1mV/V	2.5mV/V	5mV/V	10mV/V	25mV/V	50mV/V or 100mV/V
5	15.5	16.5	17.5	18.5	19.5	20.5	20.5
10	15.5	16.5	17.5	18.5	19.0	19.0	19.0
15	15.5	16.5	17.5	18.5	18.5	19.0	19.0
20	15.5	16.5	17.5	18.0	18.5	18.5	18.5
30	15.5	16.5	17.5	18.0	18.5	18.5	18.5
50	15.0	16.0	16.5	17.0	17.5	17.5	17.5
100	14.0	14.0	14.5	14.5	15.0	15.0	14.5

Note: Figures in the table above apply when the digital filter setting is 0. Add 0.5 bits effective resolution for each step on the digital filter setting e.g. if the digital filter is set at 4 add 2 bits of effective resolution to each of the figures in the table above.

Resolution in μV can be calculated using the resolution in bits figures above. These μV resolution values are calculated by the following method:

Resolution (μV) = full signal input voltage range / number of divisions of resolution.

e.g. for 2.5mV/V range, 10V excitation, full signal input voltage is 2.5mV x 10V excitation = 25mV.

For 14.5 bits (100 samples/sec., zero filter) the number of divisions is $2^{14.5}$ which equals 23170 divisions.

For 21.5 bits (5 to 30 samples/sec, filter setting of 8) the number of divisions is 2965820 ($2^{21.5}$).

Resolution (μV) at 14.5 bits = (2.5 mV x 10) / 23170 = 1.08 μV

Resolution (μV) at 21.5 bits = (2.5 mV x 10) / 2965820 = 0.0084 μV

9 Guarantee and service

The product supplied with this manual is guaranteed against faulty workmanship for a period of two years from the date of dispatch.

Our obligation assumed under this guarantee is limited to the replacement of parts which, by our examination, are proved to be defective and have not been misused, carelessly handled, defaced or damaged due to incorrect installation. This guarantee is VOID where the unit has been opened, tampered with or if repairs have been made or attempted by anyone except an authorised representative of the manufacturing company.

Products for attention under guarantee (unless otherwise agreed) must be returned to the manufacturer freight paid and, if accepted for free repair, will be returned to the customers address in Australia free of charge.

When returning the product for service or repair a full description of the fault and the mode of operation used when the product failed must be given. In any event the manufacturer has no other obligation or liability beyond replacement or repair of this product.

Modifications may be made to any existing or future models of the unit as it may deem necessary without incurring any obligation to incorporate such modifications in units previously sold or to which this guarantee may relate.

This document is the property of the instrument manufacturer and may not be reproduced in whole or part without the written consent of the manufacturer.

This product is designed and manufactured in Australia.