

RM4-TCR

DIN Rail Process Monitor/Controller
Inputs from RTD, Thermocouple
Temperature Sensor or mV
Operation & Instruction Manual

AMALGAMATED INSTRUMENT CO

Unit 5/28 Leighton Place Telephone: (02) 9476 2244 www.aicpl.com.au
Hornsby NSW 2077 Australia Facsimile: (02) 9476 2902 E-mail: sales@aicpl.com.au

AEN 80 619 963 692

Quality
Endorsed
Company

Quality System



AS/NZS
ISO 9001
Lic. No.
QEC 6187
Standards
Australia

Table of Contents

Introduction	3
Mechanical installation	4
Electrical installation	5
Signal input connections	5
Temperature sensor connections	6
Remote input connections	6
Removing the circuit boards	6
Explanation of functions	7
Error Messages	12
Function table for fully optioned instrument	13
Alarm relays.	15
Easy Alarm Access	17
Alarm mode	17
Remote input functions	19
Calibration	21
Setting up the relay PI controller	23
Specifications.	30
Technical Specifications	30
Output Options	30
Physical Characteristics	30
Guarantee & Service	31

1 Introduction

This manual contains information for the installation and operation of the RM4-TCR Din rail monitor/controller. The RM4 is a general purpose instrument which may be configured to accept a temperature sensor input from either a 100Ω RTD (Pt100), 1000Ω RTD (Pt1000), thermocouple type B, E, J, K, N, R, S or T or direct mV input in ±20, 50, 75 and 200mV ranges. A five point linearisation facility is provided for direct mV inputs. The mV input and linearisation allow the use of non standard thermocouple types.

Thermocouple temperature values are calculated using the mV signal from the thermocouple probe and the temperature from an internal temperature sensor known as a “cold junction” sensor. When a thermocouple is used the user can toggle between the temperature reading and the “cold junction” temperature reading via the ▲ and ▼ buttons, the message **c o l d** precedes the cold junction temperature.

Two separate sets of calibration scaling values can be stored with the display choice being made via the remote input. Two standard inbuilt relays are provided each of these can be programmed for on/off or PI control (pulse width or frequency).

Various combinations of one or two optional extra relays, analog (4-20mA, 0-1V or 0-10V) retransmission/PI control or serial (RS232, RS485 or RS422) communications and an isolated 12 or 24VDC isolated transmitter supply may also be optionally provided. Alarms and retransmission may be set to operate from the live input value, the display value or to follow either the peak hold, display hold, peak memory or valley memory remote input operations.

Unless otherwise specified at the time of order, your RM4 has been factory set to a standard configuration. Like all other RM4 series instruments the configuration and calibration is easily changed by the user. Initial changes may require dismantling the instrument to alter PCB links, other changes are made by push button functions.

Full electrical isolation between power supply, input voltage or current and retransmission output is provided by the RM4, thereby eliminating grounding and common voltage problems. This isolation feature makes the RM4 ideal for interfacing to computers, PLCs and other data acquisition devices.

The RM4 series of DIN Rail Process Modules are designed for high reliability in industrial applications. The 5 digit LED display provides good visibility, even in areas with high ambient light levels. A feature of the RM4-TCR is the programmable display brightness function, this allows the unit to be operated with low display brightness to reduce the instrument power consumption and to improve readability in darker areas. To reduce power consumption in normal use the display can be programmed to automatically dim or blank after a set time.

Inputs & outputs

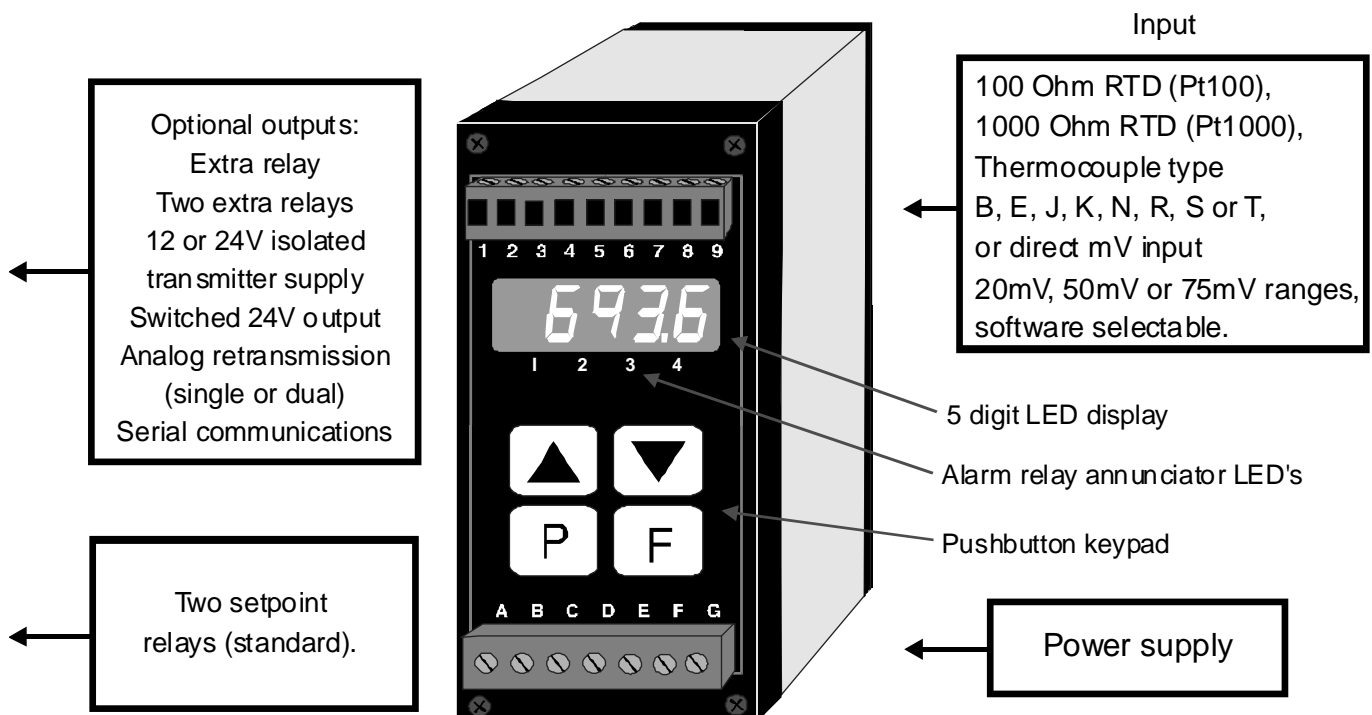

2 Mechanical installation

The RM4 is designed for DIN rail, horizontal mounting. The instrument snaps on 35mm DIN standard rails (EN50022). Cut the DIN rail to length and install where required. To install the RM4, simply clip onto the rail as shown below. To remove the RM4 lever the lower arm downwards using a broad bladed screwdriver to pull the clip away from the DIN rail.

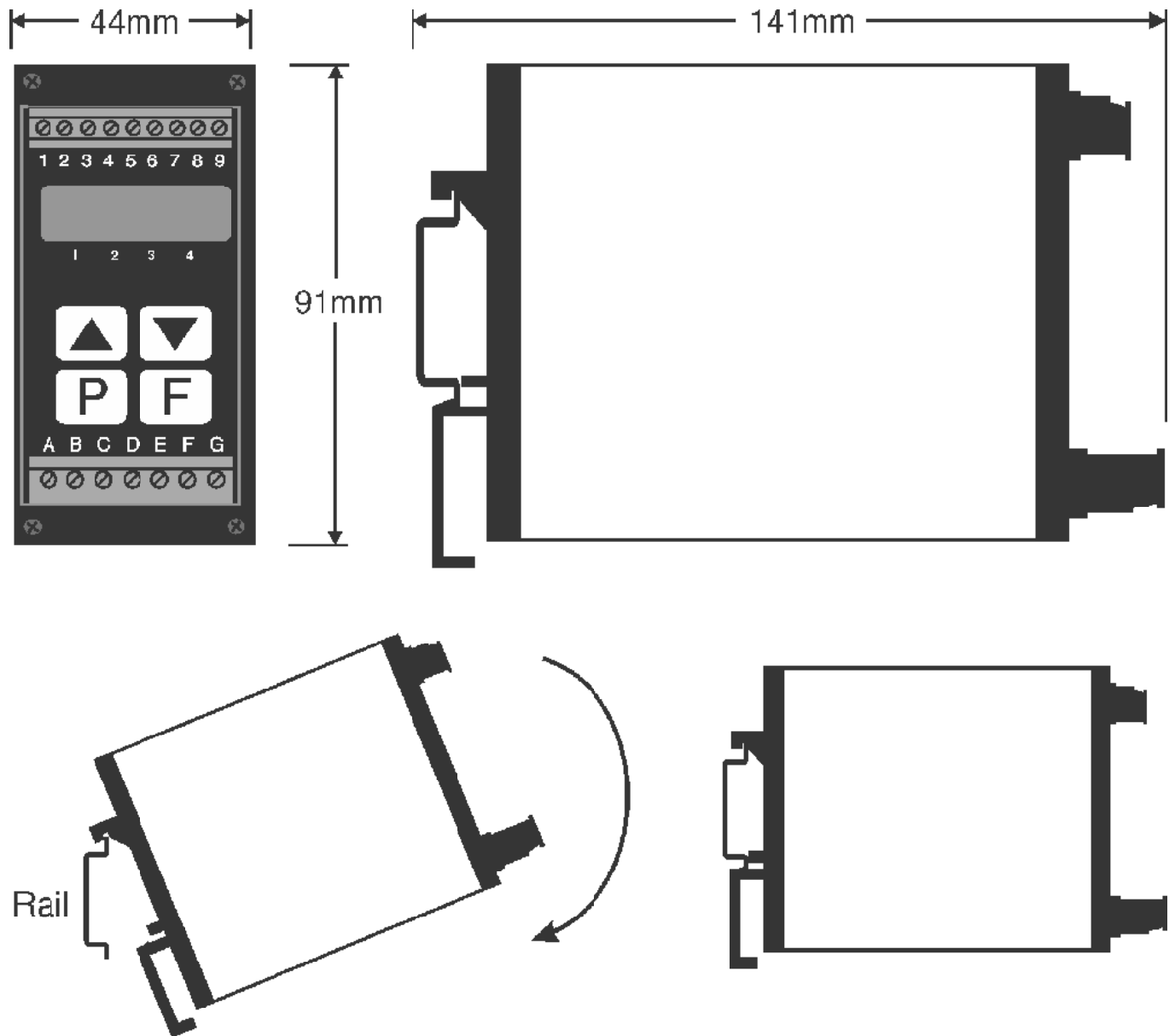

3 Electrical installation

The RM4 Meter is designed for continuous operation and no power switch is fitted to the unit. It is recommended that an external switch and fuse be provided to allow the unit to be removed for servicing.

The terminal blocks allow for wires of up to 2.5mm² to be fitted for power supply and relays 1 and 2 or 1.5mm² for input signal connections and optional outputs. Connect the wires to the appropriate terminals as indicated below. Refer to other details provided in this manual to confirm proper selection of voltage, polarity and input type before applying power to the instrument. When power is applied the instrument will cycle through a display sequence, indicating the software version and other status information, this indicates that the instrument is functioning. Acknowledgement of correct operation may be obtained by applying an appropriate input to the instrument and observing the resultant reading.

3.1 Signal input connections

Examples continued overleaf.

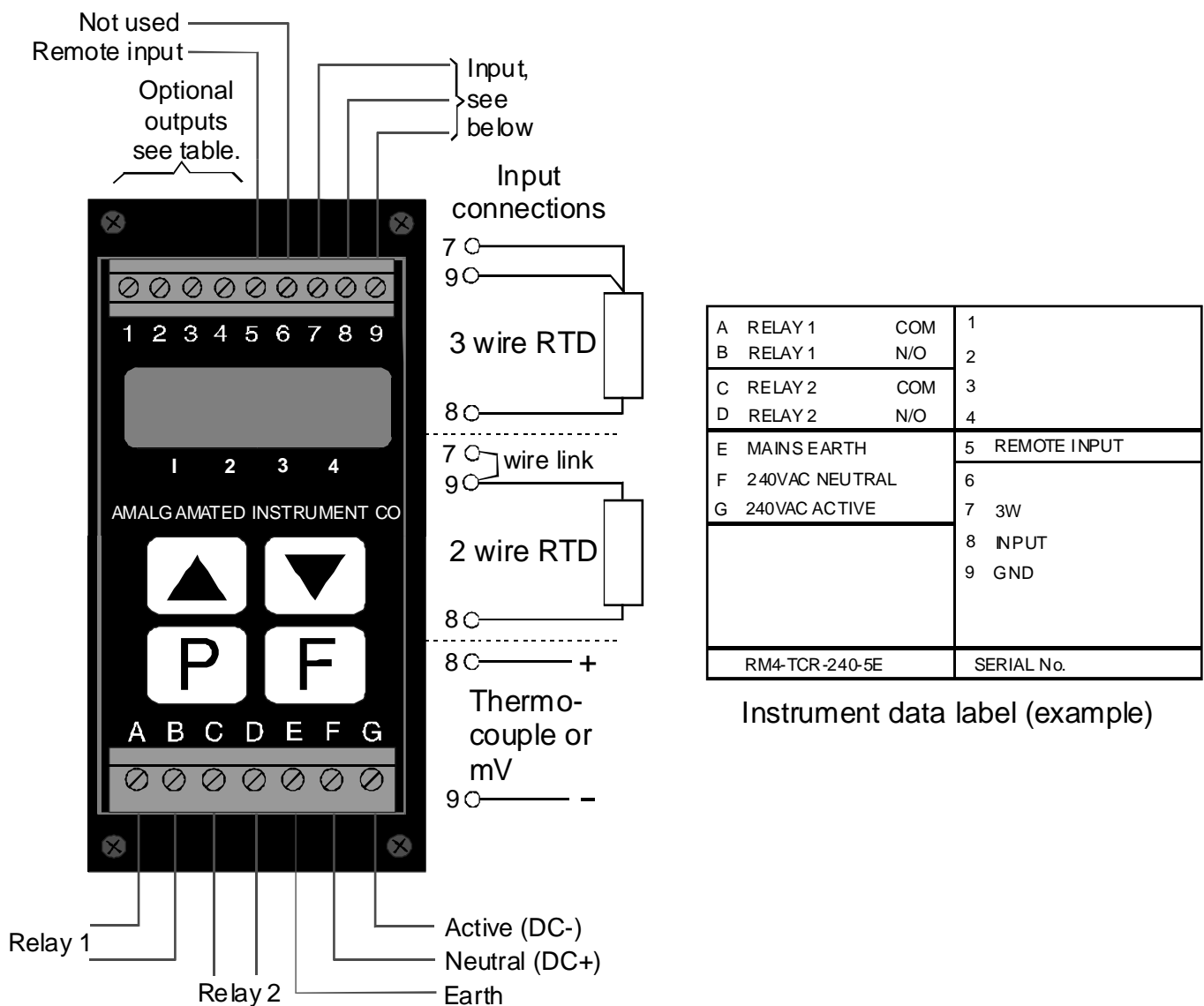

3.2 Temperature sensor connections

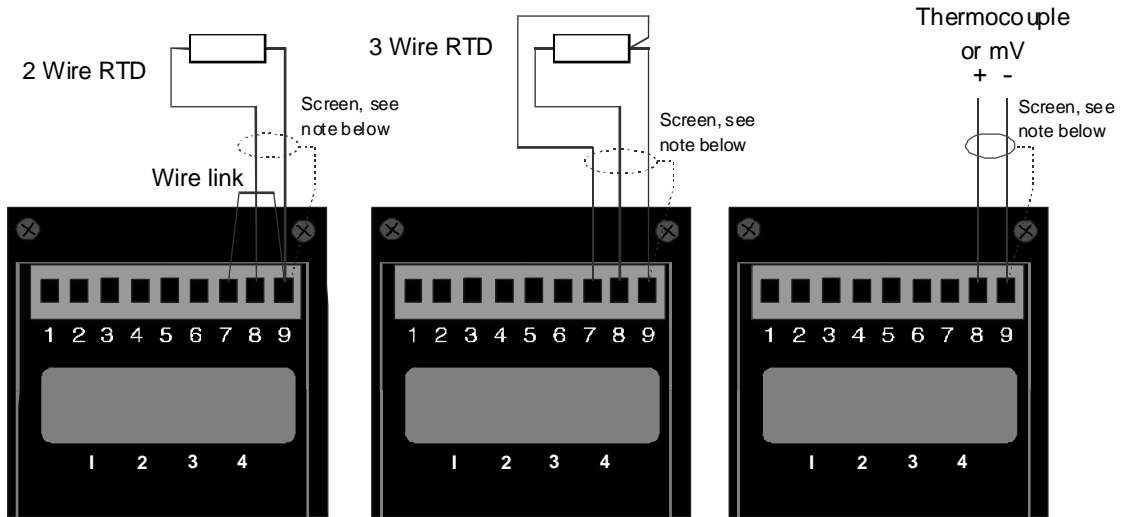

The use of screened cable is recommended. The screen should only be earthed at one point. Connect screen to the RM4 if the sensor and/or screen are not earthed at any other point.

3.3 Remote input connections

The selected remote input function can be operated via an external contact closure via a switch, relay or open collector transistor switch. A momentary action is required for functions such as **H_i** and **L_o**, a latching switch or normally closed momentary switch may be required for functions such as peak hold (**P.H.L.d**).

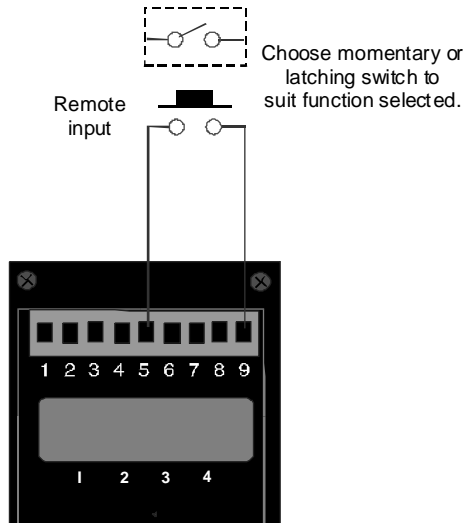

3.4 Removing the circuit boards

No hardware configuration is necessary on the RM4-TCR however if board removal is required for adjustment to any option boards fitted follow the instructions below.

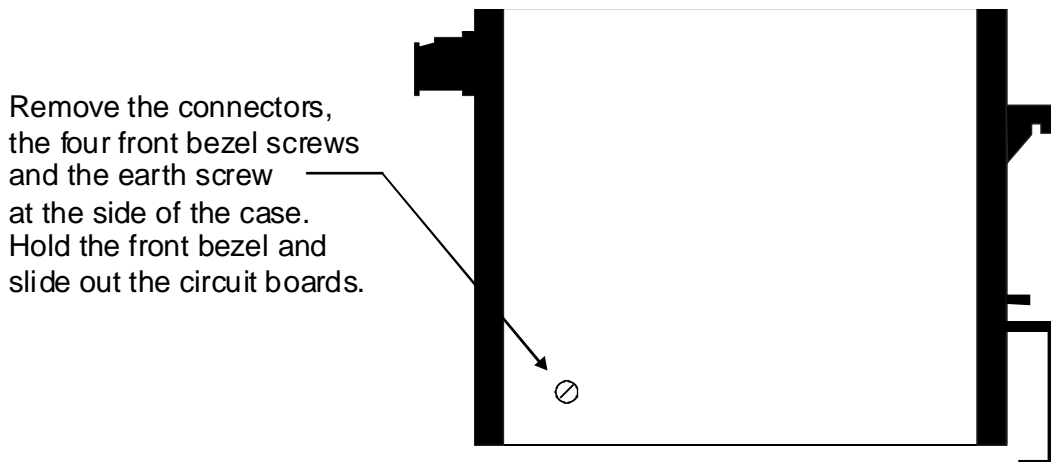

4 Explanation of functions

The RM4 setup and calibration functions are configured through a push button sequence. Two levels of access are provided for setting up and calibrating:-

FUNC mode (simple push button sequence) allows access to alarm relay, preset value & display brightness functions.

CAL mode (power up sequence plus push button sequence) allows access to all functions including calibration parameters.

Push buttons located at the front of the instrument are used to alter settings. Once **CAL** or **FUNC** mode has been entered you can step through the functions, by pressing and releasing the **F** push button, until the required function is reached. Changes to functions are made by pressing the **▲** or **▼** push button (in some cases both simultaneously) when the required function is reached.

Entering **CAL** Mode

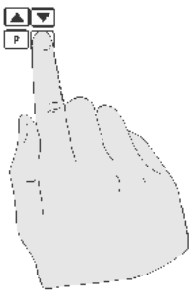

1. Remove power from the instrument. Hold in the **F** button and reapply power. The display will indicate **CAL** as part of the "wake up messages" when the **CAL** message is seen you can release the button.



2. When the "wake up" messages have finished and the display has settled down to its normal reading press, then release the **F** button.



3. Within 2 seconds of releasing the **F** button press, then release the **▲** and **▼** buttons together. The display will now indicate **FUNC** followed by the first function.

Note: If step 1 above has been completed then the instrument will remain in this **CAL** mode state until power is removed. i.e. there is no need to repeat step 1 when accessing function unless power has been removed.

Entering **FUNC** Mode



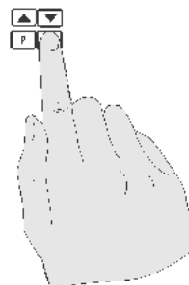

No special power up procedure is required to enter **FUNC** mode.



1. When the "wake up" messages have finished and the display has settled down to its normal reading press, then release the **F** button.



2. Within 2 seconds of releasing the **F** button press, then release the **▲** and **▼** buttons together. The display will now indicate **FUNC** followed by the first function.

Function	Description
C.5Et	Analog control setpoint - seen only when the analog retransmission option is fitted and FEE c b r i is set to on . Refer to the separate "RM4 DIN Rail Meter Optional Output Addendum" booklet supplied when this option is fitted.
AxSP	Alarm relay setpoint - displays and sets the alarm relay PI control setpoint. This function is only seen when the alarm operating mode is set to pulse width or frequency PI control operation. Refer to the "Setting up the relay PI controller" chapter if this mode is used.
AxLo	Alarm relay low setpoint - see "Alarm relays" chapter. Displays and sets each alarm low setpoint value.
AxH.	Alarm relay high setpoint - see "Alarm relays" chapter. Displays and sets each alarm high setpoint value.
AxHY	Alarm relay hysteresis [deadband] - see "Alarm relays" chapter. Displays and sets the alarm hysteresis limit. This value is common for both high and low setpoint values.
Ax t t	Alarm relay trip time - see "Alarm relays" chapter. Displays and sets the alarm trip time in seconds/tenths of seconds in the range 0.0 to 999.9 seconds. This value is common for both alarm high and low setpoint values.
Ax r t	Alarm relay reset time - see "Alarm relays" chapter. Displays and sets the alarm reset time in seconds/tenths of seconds in the range 0.0 to 999.9 seconds. This value is common for both alarm high and low setpoint values.
Ax n. o or Ax n. c	Alarm relay normally open or normally closed - see "Alarm relays" chapter. Displays and sets the alarm relay action to normally open (de-energised) or normally closed (energised), when no alarm condition is present.
Ax.SP, Ax.t 1, Ax.t 2 etc.	Alarm relay operation independent setpoint or trailing - see "Alarm relays" chapter.
b r 9 t	Display brightness - displays and sets the digital display brightness. The display brightness is selectable from 1 to 15 where 1 = lowest intensity and 15 = highest intensity. This function is useful for reducing glare in darkened areas.
d u L L	Remote display brightness - displays and sets the level for remote input brightness switching, see "Remote input functions" chapter. See also d.OFF SECS function below.
r E C _	Analog recorder/retransmission output low value - seen only when the analog retransmission option is fitted. Refer to the separate "RM4 DIN Rail Meter Optional Output Addendum" booklet supplied when this option is fitted. Displays and sets the analog retransmission output low value (4mA or 0V) in displayed engineering units. e.g. for a 4-20mA retransmission if it is required to retransmit 4mA when the display indicates 0 then select 0 at this function via the  or  button.
r E C ^	Analog recorder/retransmission output high value - seen only when the analog retransmission option is fitted. Refer to the separate "RM4 DIN Rail Meter Optional Output Addendum" booklet supplied when this option is fitted. Displays and sets the analog retransmission output high value (20mA, 1V or 10V) in displayed engineering units. e.g. if it is required to retransmit 20mA when the display indicates 500 then select 500 at this function via the  or  button.
r E C _ C h 2	Second analog recorder/retransmission output low value - seen only when the dual analog retransmission option is fitted. See r E C _ function for description of operation. See also r E C 2 function (analog output 2 mode).
r E C ^ C h 2	Second analog recorder/retransmission output high value - seen only when the dual analog retransmission option is fitted. See r E C ^ function for description of operation. See also r E C 2 function (analog output 2 mode).
CAL mode functions Entry via CAL mode (see first page of this chapter) or the ALCS function must be set to ALL in order to view and adjust the functions which follow.	

d.oFF SECS	Auto display dimming timer - this function allows a time to be set after which the display brightness (set by the br 9t function) will automatically be set to the level set at the duLL function. The auto dimming feature can be used to reduce power consumption. The function can be set to any value between 0 and 9999 seconds. A setting of 0 disables the auto dimming. The display brightness can be restored by pressing any of the instruments front push buttons. The display brightness will also be restored whilst one or more alarm relays is activated.
Rx OPEF	Relay operating mode - allows selection of standard alarm on/off setpoint operation (Rx.AL) using the alarm functions described in this chapter or PI control operation (Rx.tP or RxFr). Refer to the "Setting up the relay PI controller" chapter for details of the PI control operations and functions.
ctrl SPAN	Relay PI control span - PI control span value. Refer to the "Setting up the relay PI controller" chapter for details of the PI control operations and functions.
Rx.P9	Relay PI control proportional gain - Refer to the "Setting up the relay PI controller" chapter for details of the PI control operations and functions.
Rx.I 9	Relay PI control integral gain - Refer to the "Setting up the relay PI controller" chapter for details of the PI control operations and functions.
Rx.I L	Relay PI control integral low limit - Refer to the "Setting up the relay PI controller" chapter for details of the PI control operations and functions.
Rx.I H	Relay PI control integral high limit - Refer to the "Setting up the relay PI controller" chapter for details of the PI control operations and functions.
Rx.b5	Relay PI control bias - Refer to the "Setting up the relay PI controller" chapter for details of the PI control operations and functions.
Rx.dc	Relay PI control cycle period - Refer to the "Setting up the relay PI controller" chapter for details of the PI control operations and functions.
Rx.dr	Relay PI control pulse on duration (frequency PI only) - Refer to the "Setting up the relay PI controller" chapter for details of the PI control operations and functions.
dr nd	Display rounding - displays and sets the display rounding value. This value may be set to 0 - 5000 displayed units. Display rounding is useful for reducing the instrument resolution without loss of accuracy in applications where it is undesirable to display to a fine tolerance. (example: if set to 10 the instrument will display in multiples of 10).
dCPt	Decimal point selection - displays and sets the decimal point. By pressing the ▲ or ▼ keypads the decimal point position may be set. The display will indicate as follows: 0 (no decimal point), 0. 1 (1 decimal point place), 0.02 (2 decimal point places), 0.003 (3 decimal point places) or 0.0004 (4 decimal point places). RTD and thermocouple inputs are limited to 2 decimal point places. mV input allow up to 4 decimal places.
FLtr	Digital filter - displays and sets the digital filter value. Digital filtering is used for reducing susceptibility to short term interference. The digital filter range is selectable from 0 to 8 , where 0 = none and 8 = most filtering. A typical value for the digital filter would be 3 . The digital filter uses a weighted averaging method of filtering which will increase the display update time at higher settings.
FEE ctrl	Analog control on or off - seen only when the analog retransmission option is fitted. Refer to the separate "RM4 DIN Rail Meter Optional Output Addendum" booklet supplied when this option is fitted.
C.SPAN	Control span - seen only when the analog retransmission option is fitted and FEE ctrl is set to on . Refer to the separate "RM4 DIN Rail Meter Optional Output Addendum" booklet supplied when this option is fitted.
C.P9	Control proportional gain - seen only when the analog retransmission option is fitted and FEE ctrl is set to on . Refer to the separate "RM4 DIN Rail Meter Optional Output Addendum" booklet supplied when this option is fitted.
C.P0	Control proportional offset - seen only when the analog retransmission option is fitted and FEE ctrl is set to on . Refer to the separate "RM4 DIN Rail Meter Optional Output Addendum" booklet supplied when this option is fitted.
C.I 9	Control integral gain - seen only when the analog retransmission option is fitted and FEE ctrl is set to on . Refer to the separate "RM4 DIN Rail Meter Optional Output Addendum" booklet supplied when this option is fitted.

CI L.H	Control integral limit high - seen only when the analog retransmission option is fitted and FEE ctrl is set to on . Refer to the separate "RM4 DIN Rail Meter Optional Output Addendum" booklet supplied when this option is fitted.
CI L.L	Control integral limit low - seen only when the analog retransmission option is fitted and FEE ctrl is set to on . Refer to the separate "RM4 DIN Rail Meter Optional Output Addendum" booklet supplied when this option is fitted.
FEE SPAC	Control setpoint access on or off - seen only when the analog retransmission option is fitted and FEE ctrl is set to on . Refer to the separate "RM4 DIN Rail Meter Optional Output Addendum" booklet supplied when this option is fitted.
INPUT TYPE	Input type - the input type is selected at this function. The input types available are: 100 - 100Ω RTD (Pt100) temperature sensor 1000 - 1000Ω RTD (Pt1000) temperature sensor t 1 b - type B thermocouple t 2 E - type E thermocouple t 3 J - type J thermocouple t 4 - type K thermocouple (no letter is shown since "K" cannot be produced on display) t 5 n - type N thermocouple t 6 r - type R thermocouple t 7 S - type S thermocouple t 8 t - type T thermocouple E 20 - ±20mV input E 50 - ±50mV input E 75 - ±75mV input E 200 - ±200mV input
DEG TYPE	Degree measurement type - select °C for Celsius measurement or °F for Fahrenheit
DISP UNIT	Display units - allows selection of display units to appear alongside the temperature. Note that if a display unit is selected only 3 digits remain for the temperature value. A -err - error message will be seen if the value to be displayed is too high to fit onto the display, for example the display may be limited to a display such as 99.9°C . Selections are: NONE - no temperature units e.g. a display such as 23.4 °C - reading shows °C e.g. a display such as 23.4°C °F - reading shows °F e.g. a display such as 23.4°F ° - reading shows ° e.g. a display such as 23.4° ℃ - reading show ℃ e.g. a display such as 23.4℃ F - reading show F e.g. a display such as 23.4F
CAL DEG	Temperature calibration for RTD or thermocouple input - see "Calibration" chapter.
LINEPTS	Linearisation points - displays and sets the number of linearisation points for mV input ranges only. The number of points can be set from 2 (linear display) to 5 (linearised display). Use 3 or more points only if the input needs to be linearised before being displayed. The required number of live input scaling functions will be seen to allow calibration at 2 or more points e.g. CAL 1 , CAL 2 and CAL 3 if three points are chosen.
CAL 1, CAL 2 etc.	Calibration scaling points, direct mV input only - see "Calibration" chapter.
UCAL	Uncalibration - see "Calibration" chapter. Used to set the instrument back to the factory calibration values.

<p>P.but</p>	<p>P button function - the function of the P button is programmable in the same manner as the remote input. The P button selection will override the selection made under the F.I NP function if both have the same functions selected. Upon reaching the P.but function the choices shown below are available, see "Remote input functions" chapter for a full description of each choice. Note: When using Lo.H, or H.Lo the high/low values held in memory can be reset (i.e. the memory is cleared) by holding the P button pressed for 2 seconds. The RM4 does not start to store the peak and valley readings until the instrument has been powered up for 5 seconds, this is to ensure that no erroneous peak or valley readings are stored during power up. Once the P button has been pressed to bring up a peak or valley display the display will revert to the normal live display after approx. 20 seconds, alternatively the display will revert to the normal live display if the F button is pressed.</p> <p>Choices available for the P button function are:</p> <p>NONE - no function</p> <p>H - peak memory (message H flashes before peak reading)</p> <p>Lo - valley memory (message Lo flashes before valley reading)</p> <p>H, Lo - toggles between peak and valley memory (message H or Lo flashes before the peak or valley reading)</p>
<p>F.I NP</p>	<p>Remote input - displays and sets the special function input selection, see "Remote input functions" chapter.</p>
<p>ACCESS</p>	<p>Alarm relay access mode - see "Alarm relays" chapter.</p>
<p>SPAC</p>	<p>Setpoint access - sets the FUNC mode access to the alarm relays set points. The following choices are available; R 1 - Allows setpoint access to alarm 1 only. R 1-2 - Allows access to alarms 1 and 2 only. R 1-3 - Allows access to alarms 1, 2 and 3 only etc. up to the maximum number of relays fitted. To allow this function to operate the remote input F.I NP function must be set to SPAC.</p>
<p>R1 to R4</p>	<p>Alarm mode - see "Alarm relays" chapter.</p>
<p>FEC</p>	<p>Analog retransmission mode - the following choices are available for analog or serial retransmission operation mode:</p> <p>d: SP - display mode. The retransmission output will follow whatever value is on the 7 segment display. For example if the remote input is set to P.HL d then the 7 segment and retransmission output will indicate the peak held value when the remote input is short circuited and will indicate the live input if the remote input opens.</p> <p>P.HL d - peak hold mode. The 7 segment display and retransmission value will indicate the peak value only whilst the peak value function is operated via a contact closure on the remote input i.e. the 7 segment display and retransmission can rise but not fall whilst the remote input switch is closed. When the remote input switch is opened the retransmission value will remain fixed i.e. it will not rise or fall, although the 7 segment display value will be free to alter. This peak retransmission output can be cleared by closing the remote input switch for another operation or by removing power from the instrument. Note: In this mode the retransmission will show a zero reading until the remote input is operated for the first time after switch on.</p> <p>d.HL d - display hold mode. The 7 segment display and retransmission value will be held whilst the remote input display hold switch is closed. When the switch is opened the retransmission value will remain fixed at the held value although the 7 segment display value will be free to alter. The held retransmission output can be cleared by closing the remote input switch for another operation or by removing power from the instrument.</p> <p>H - peak (max.) memory mode. With the peak remote input switch open the retransmission will indicate the peak value in memory i.e. the retransmission output can rise but not fall. The retransmission output can be reset by clearing the memory. The memory may be cleared either by closing the remote input switch for approximately 2 seconds or by removing power to the instrument.</p> <p>Lo - valley (min.) memory mode. With the valley remote input switch open the retransmission will indicate the valley (min.) value in memory i.e. the retransmission output can fall but not rise. The retransmission output can be reset by clearing the memory. The memory may be cleared either by closing the remote input switch for approximately 2 seconds or by removing power to the instrument.</p> <p>L, LE - live input mode. The retransmission will follow the electrical input and will not necessarily follow the 7 segment display. For example if the remote input is set for peak hold operation then when the remote input is closed the 7 segment display will only show the peak value but the retransmission will be free to change to follow the electrical input.</p>

FEC2	Analog retransmission mode for analog output 2, only seen if the second analog output option is fitted. This function allows the same options as the FEE function described above.
bAud	Set baud rate - seen only with serial output option - Refer to the separate "RM4 DIN Rail Meter Optional Output Addendum" booklet supplied when this option is fitted. Select from 300 . 600 . 1200 . 2400 . 4800 . 9600 . 19.2 or 38.4 .
Prty	Set parity - seen only with serial output option - Refer to the separate "RM4 DIN Rail Meter Optional Output Addendum" booklet supplied when this option is fitted. Select parity check to either NONE , EVEN or odd .
O.Pub	Set RS232/485 interface mode - Refer to the separate "RM4 DIN Rail Meter Optional Output Addendum" booklet supplied when this option is fitted. Select d , SP , Cont , POLL , ~.bus or R.bus Allows user to select the RS232/485 interface operation as follows:- d, SP Sends image data from the display without conversion to ASCII. Cont Sends ASCII form of display data every time display is updated. POLL Controlled by computer or PLC as host. Host sends command and instrument responds as requested. ~.bus Modbus RTU communications. R.bus This is a special mode for use with Windows Download software. Refer to "Users"Guide when this software is used.
Addr	Set unit address for polled (POLL) mode (0 to 31) - Refer to the separate "RM4 DIN Rail Meter Optional Output Addendum" booklet supplied when this option is fitted. Allows several units to operate on the same RS485 interface reporting on different areas etc. The host computer or PLC may poll each unit in turn supplying the appropriate address. The unit address ranges from 0 to 31 (DEC) but is offset by 32 (DEC) to avoid clashing with ASCII special function characters (such as <STX> and <CR>). Therefore 32 (DEC) or 20 (HEX) is address 0, 42 (DEC) or 2A (HEX) addresses unit 10.

Returning to the normal measure mode

When the calibration procedure has been completed it is advisable to return the instrument to the normal mode (where calibration functions cannot be tampered with). To return to the normal mode, turn off power to the instrument, wait a few seconds and then restore power.





4.1 Error Messages

"- - - -" - This display indicates that the input signal is higher than expected for the selected input range or that the input is open circuit e.g. broken sensor wire.

"-or-" - This display indicates an overrange reading. This means that the instrument is not being able to display the number because it is too large e.g. above **99999** on a 5 digit display. Check that the calibration scaling figures are correct.

CAL SPAN Err - this display indicates a calibration span error caused by the input signal being too low the case of thermocouple inputs or too close to another calibration point input in the case of mV inputs. Check that the input is correct and that the correct sensor type has been chosen at the **INPUT TYPE** function. If correct perform a **UCAL** function operation to reset the calibration memory then try calibration scaling again.

CAL OFFSET Err - this display indicates a calibration offset error caused by the input being too far away from the theoretical value for the input. For example the RM4 instrument expects the resistance of a 100Ω RTD input to be 138.5Ω at 100 degrees. If during calibration the user places an input which is more than 20% away from 138.5Ω and tries to scale the meter to read 100 degrees the offset error message will be seen and the instrument will not accept the scaling.

Cold or **INPUT** - these are not error messages but indicate that the  or  button has been used to view the thermocouple cold junction temperature or the mV input level. To revert to temperature measurement use the  or  button to toggle to the temperature display which is preceded by a **°C** message.

5 Function table for fully optioned instrument

Initial display	Meaning of display	Next display	Default Setting	Record Your Settings	
CLSEt	Analog PI control setpoint	Value in memory	0		
Rx.SP	Relay PI control setpoint	Value in memory	0	See following table	
RxLo	Alarm x low setpoint value	Setpoint value or OFF	OFF	See following table	
RxH₁	Alarm x high setpoint value	Setpoint value or OFF	1000	See following table	
RxHY	Alarm x hysteresis	Hysteresis value in measured units	10	See following table	
RxTt	Alarm x trip time (seconds)	0.0 to 999.9	0.0	See following table	
Rxrt	Alarm x reset time (seconds)	0.0 to 999.9	0.0	See following table	
Rxn.o or Rxn.c	Alarm x action N/O or N/C	Rxn.o or Rxn.c	Rxn.o	See following table	
Rx.SP or Rx.t 1	Alarm x independent or trailing setpoint 1,2 etc.	Rx.SP or Rx.t 1	Rx.SP		
br9t	Digital display brightness	1 to 15 (15 = highest brightness)	15		
dULL	Remote brightness control	0 to 15 (15 = highest brightness)	1		
d.OFF SECS	Display auto dimming timer (seconds)	0 to 9999	0		
rEC₋	Analog output low limit	Value in memory	0		
rEC₊	Analog output high limit	Value in memory	100		
rEC₋ ch2	Second analog output low limit	Value in memory	0		
rEC₊ ch2	Second analog output high limit	Value in memory	100		
Functions below are accessible via CLRL mode only					
Rx OPEr	Alarm x operation mode	Rx.RL, Rx.tP or Rx.Fr	Rx.RL	See following table	
P I C o n t r o l	ctr: SPAN	Span for relay PI control	Value in memory	100	See following table
	Rx.P9	Proportional gain for relay PI control	- 19.999 to 32.767	1.000	See following table
	Rx.I 9	Integral gain for relay PI control	- 19.999 to 32.767	0.000	See following table
	Rx.I L	Low integral limit for relay PI control	0.0 to 100.0	100.0	See following table
	Rx.I H	High integral limit for relay PI control	0.0 to 100.0	100.0	See following table
	Rx.b5	Bias for relay PI control	0.0 to 100.0	50.0	See following table
	Rx.dc	Duty cycle for relay PI control	0 to 250	10	See following table
	Rx.dr	Duration for relay PI control (frequency mode only)	0.0 to 25.0	1.0	See following table
drnd	Display rounding selects resolution	Value in memory	1		
dCPt	Display decimal point	Decimal Pt position (e.g. 0.1 or 0.02)	0		
FLtr	Digital filter range 0 to 8	0 to 8 (8 = most filtering)	2		
P I C o n t r o l	rEC ctr:	Analog PI control on or off	on or OFF	OFF	
	CLSPAN	Analog PI control span	Value in memory	100	
	CLP9	Analog PI control proportional gain	- 19.999 to 32.767	1.000	
	CLP0	Analog PI control proportional offset	0 to 100	0.0	
	CLI 9	Analog PI control integral gain	- 19.999 to 32.767	0.000	
	CLL.H	Analog PI control integral limit high	0 to 100	100.0	
	CLL.L	Analog PI control integral limit low	0 to 100	100.0	
	rEC SPAC	Analog PI control setpoint access on or off	on or OFF	OFF	

INPUT TYPE	Temperature sensor/input type	100, 1000, 16, 2E, 3J, 4, 5n, 6r, 7S, 8E, E20, E50, E75 or E200	100	
DES TYPE	Degrees C or F measurement	°C or °F	°C	
DISP UNITS	Units to appear on display	NONE, °C, °F, °C or F	NONE	
CAL DES	Temperature alibration	See calibration chapter	n/a	
LINPTS	Lineariser points for mV input	2, 3, 4 or 5	2	
CAL 1, CAL 2 etc.	mV input calibration points	See calibration chapter	n/a	
UCAL	Uncalibrate	CAL CLR	n/a	
P.BUT	 Button function	NONE, Hi, Lo or Hi, Lo	NONE	
INPUT	Remote Input 1	NONE, P.HLd, d.HLd, Hi, Lo, Hi, Lo, SP.Ac, No.Ac, CAL.S, or dULL	NONE	
ACCESS	Setpoint access mode	OFF, EASY, NONE or ALL	OFF	
SPAC	Setpoint access	R1, R1-2 etc.	R1	
Rx	Alarm mode relays	L, UE, P.HLd, d.HLd, Hi, Lo or di SP	L, UE	See following table
FEC	Analog retransmission 1 mode	L, UE, P.HLd, d.HLd, Hi, Lo or di SP	L, UE	
FEC2	Analog retransmission 2 mode	L, UE, P.HLd, d.HLd, Hi, Lo or di SP	L, UE	
BAUD RATE	Baud rate	300, 600, 1200, 2400, 4800, 9600, 19.2 or 38.4	9600	
PRTY	Parity select	NONE, EVEN or ODD	NONE	
OPUT	Serial output mode	POLL, Cont, di SP, A.buS or R.buS	Cont	
ADDR	Set unit address for poll mode	0 to 31	0	

Note: Functions in the shaded areas on this table will be displayed only when those particular options are fitted. Refer to the separate “RM4 DIN Rail Meter Optional Output Addendum” booklet supplied when optional outputs are fitted.

Settings for relays - record settings here					
		A1	A2	A3	A4
RxSP				n/a	n/a
RxLo					
RxHi					
RxHY					
RxLk					
RxRk					
Rxn.o or Rxn.c					
Rx.SP or Rx.t 1		n/a			
Rx OPER				n/a	n/a
P I C O N T R O L	ctrl SPAN			n/a	n/a
	Rx.P9			n/a	n/a
	Rx.I 9			n/a	n/a
	Rx.I L			n/a	n/a
	Rx.I H			n/a	n/a
	Rx.bS			n/a	n/a
	Rx.dc			n/a	n/a
	Rx.dr			n/a	n/a
Rx					

6 Alarm relays

The RM4 is provided with 2 alarm relays as standard. Relays 1 and 2 can be set up for on/off or PI control the mode is selected at the **Rx**. **OPER** function. See “Setting up the relay PI controller” if PI control is used. One or two extra optional independent alarm relays may also be provided, these relays are designated **R1**, **R2** etc. Each relay has the following parameters which may be set by the user:

1. Low trip point, adjustable in measurement units
2. High trip point, adjustable in measurement units
3. Alarm hysteresis, adjustable in measurement units
4. Alarm trip time, adjustable in one second steps
5. Alarm reset time, adjustable in one second steps
6. N/O or N/C relay operation
7. Independent or trailing alarms (available on relays 2 and upwards)
8. Alarm to follow a special mode

Note that the alarm settings are not changed when calibration scaling channels are changed. The alarms operate in the following way:

If the measured value is above the High Trip Point, or below the Low Trip Point, the alarm trip timer starts. This timer is reset if the measured value drops below the High Trip Point or above the Low Trip point. When the alarm trip timer's time exceeds the Trip delay time, the alarm is operated.

When the alarm has tripped, the measured value is compared to the High Set Point less the Hysteresis value and the Low Set Point plus the Hysteresis value. If it is less than the High Set Point less the Hysteresis value and greater than the Low Set Point plus the Hysteresis value, the alarm is reset.

RxL (alarm low setpoint)

Displays and sets the low setpoint value for the designated alarm relay. The low alarm setpoint may be disabled by pressing the **▲** and **▼** keypads simultaneously. When the alarm is disabled the display will indicate **OFF**. Use **▲** or **▼** to adjust the setpoint value if required. The alarm will activate when the displayed value is lower than the **RxL** setpoint value. Each relay may be configured with both a low and high setpoint if required, if so the relay will be activated when the display reading moves outside the band set between low and high setpoints.

RxH (alarm high setpoint)

Displays and sets the high setpoint value for the designated alarm relay. The high alarm setpoint may be disabled by pressing the **▲** and **▼** keypads simultaneously. When the alarm is disabled the display will indicate **OFF**. Use **▲** or **▼** to adjust the setpoint value if required. The alarm will activate when the displayed value is higher than the **RxH** setpoint value. Each relay may be configured with both a low and high setpoint if required, if so the relay will be activated when the display reading moves outside the band set between low and high setpoints.

Alarm Hysteresis

Displays and sets the alarm hysteresis limit and is common for both high and low setpoint values. The hysteresis value may be used to prevent too frequent operation of the setpoint relay when the measured value stays close to the setpoint. Without a hysteresis setting (**RxHY** set to zero) the alarm will activate when the display value goes above the alarm setpoint (for high alarm) and will reset when the display value falls below the setpoint, this can result in repeated on/off switching of the relay at around the setpoint value. The hysteresis setting operates as follows:

In the high alarm mode, once the alarm is activated the input must fall below the setpoint value minus the hysteresis value to reset the alarm.

e.g. if **R1H** is set to **50.0** and **R1HY** is set to **3.0** then the setpoint output relay will

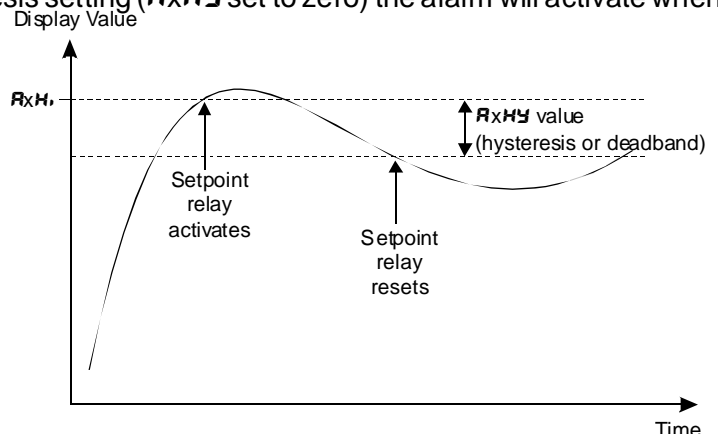

activate once the display value goes above **50.0** and will reset when the display value goes below **47.0** (50.0 minus 3.0).

In the low alarm mode, once the alarm is activated the input must rise above the setpoint value plus the hysteresis value to reset the alarm.

e.g. if **A1Lo** is set to **20.0** and **A1HY** is set to **10.0** then the alarm output relay will activate when the display value falls below **20.0** and will reset when the display value goes above **30.0** (20.0 plus 10.0).

The hysteresis units are expressed in displayed engineering units.

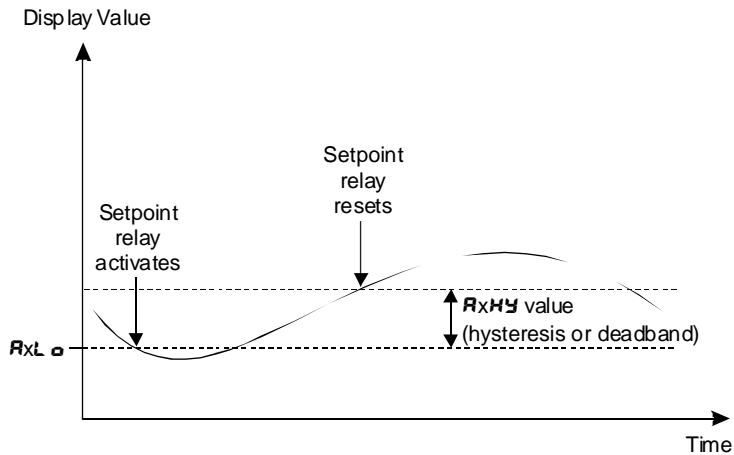

AxLt (alarm trip time)

The alarm trip time determines how long the measured value has to be above the high trip point or below the low trip point before an alarm is given. This can be used to prevent false alarms on noisy inputs. The value is set in seconds, with a range of **0** to **60** seconds. For normal operation a delay of three to five seconds is suitable.

AxRt (alarm reset time)

The alarm reset time determines how long the measured value has to be below the high trip point or above the low trip point before the alarm is reset. The value is set in seconds, with a range of **0** to **60** seconds. For normal operation a delay of zero seconds is suitable.

AxNo/AxNc (alarm relay N/O or N/C operation)

Each alarm may be programmed to operate as a normally open (N/O e.g. **A1No**) or normally closed (N/C e.g. **A2Nc**) device. A N/O relay is de-energised when no alarm condition is present and is energised when an alarm condition is present. A N/C relay is normally energised and is de-energised when an alarm condition is present. The N/C mode is useful for power failure detection.

AxSP/AxTl (trailing or independent set points)

A function exists to allow relays, other than relay 1, to be used as independent relays with their own set points or they may be made to “trail” another relays setpoint. For example if **A2SP** is selected then alarm 2 will act as an independent relay. If **A2Tl 1** is selected then the alarm 2 relay will trail alarm 1 relay. With **A2Tl 1** selected if alarm 1 high setpoint is set to 50 and alarm 2 high set point set to 20 then alarm 2 relay will operate at a display of 70 (50 + 20). Alternatively alarm 2 could be set to operate at 30 (50 - 20) by setting alarm 2 high setpoint to -20.

Trailing Alarm Table Showing Possible Alarm Assignments			
	A2	A3	A4
A1	A2.Tl 1	A3.Tl 1	A4.Tl 1
A2		A3.Tl 2	A4.Tl 2
A3			A4.Tl 3

ACCESS (access mode)

The access mode function **ACCESS** has four possible settings namely **OFF**, **EASY**, **NONE** and **ALL**. If set to **OFF** the mode function has no effect on alarm relay operation. If set to **EASY** the easy alarm access mode will be activated, see details below. If set to **NONE** there will be no access to any functions via **FUNC** mode, entry via **CAL** mode must be made to gain access to alarm functions. If set to **ALL** then all functions are available via **FUNC** mode i.e. there is no need to enter via **CAL** mode.

SPAC (setpoint access)

The setpoint access function allows the user to select which of the alarm relays can be accessed via **FUNE** mode. For an instrument with four relays the choices are **R 1** (relay 1 only), **R 1-2** (alarm relay 1 and 2 only), **R 1-3** (alarm relays 1, 2 & 3 only) or **R 1-4** (all four alarm relays accessible). Note if you wish to block access to all relay setpoints via **FUNE** mode the **ACCESS** function must be set to **NONE** or the **F: NP** function set to **No.Ac**.

6.1 Easy Alarm Access

The RM4 has an easy alarm access facility which allows operator access to the selected alarm setpoints (only to the setpoints selected at the **SPAC** function) simply by pressing the **F** button. The first setpoint will then appear and changes to this setpoint may be made to this setpoint via the **▲** or **▼** buttons. Press the **F** button to accept any changes or to move on to the next setpoint.

The instrument must be set in the manner described below to allow the easy access facility to work:

1. Either the **ACCESS** function must be set to **EASY** or the **F: NP** function must be set to **SP.AC**. If the **ACCESS** function is used the remote input function **F: NP** can be assigned to a different use.
2. The selected relays must have a setpoint, nothing will happen if all the alarm relay setpoints are set to **OFF**.
3. The **SP.AC** function must be set to allow access to the relays required e.g. if set to **R 1-2** then the easy access will work only with alarm relays 1 and 2 even if more relays are fitted.
4. The instrument must be in normal measure mode i.e. if the instrument is powered up so that it is in **CAL** mode then the easy access will not function. If in doubt then remove power from the instrument, wait for a few seconds then apply power again.
5. If the easy access facility is used then the only way to view or alter any other function settings is to power up via **CAL** mode i.e. there is no entry to **FUNE** mode unless the instrument is powered up in **CAL** mode.

6.2 Alarm mode

The alarm mode functions (**R1** to **R4**) allow the alarm relays to follow either the live input value (**L: UE**), the peak hold function (**P.HLD**), the display hold (**d.HLD**), the peak memory (**H:**) or valley memory (**Lo**) or the display value (**d: SP**). Other than **L: UE** or **d: SP** operation a remote input or **P** button must also be set to the function required.

Example 1 - **R1** is set to **L: UE**

With the alarm function set to follow the live input value the alarm will activate at the alarm high/low settings. Thus if **R1Lo** is set to **50** and **R1Hi** is set to **100** then alarm 1 will activate if the display reading falls below **50** or goes above **100**. For example if the remote input is set to operate the peak hold the alarm will still be free to operate from the rising and falling live input value even if the display is showing a held value.

Example 2 - **R1** is set to **P.HLD** and **F: NP** is set to **P.HLD**

If **R1Hi** is set to **100** then it will operate whenever the display shows a value over **100**. If the peak value exceeds **100** when the remote input is closed then alarm 1 will activate and will not reset until the remote input opens and the display value falls below **100**.

Example 3 - **R1** is set to **d.HLD** and **F: NP** is set to **d.HLD**

If **R1Lo** is set to **5** then it will operate whenever the display shows a value below **5**. If the display hold remote input is operated at a value above **5** then the alarm will not activate whilst the remote input remains closed, no matter what the electrical input. Likewise if the remote input is operated at a value below **5** then alarm will not de activate until the remote input is opened and the display value goes above 5.

Example 4 - **R1** is set to **H:** and **F: NP** is set to **H:**

If **R1Hi** is set to **50** and the peak memory value becomes greater than **50** then alarm 1 will be constantly activated at this point and will only become de activated when the memory is reset at a value below **50**. The memory can be reset by holding the remote input closed for 2-3 seconds. Note that in this case the alarm can be activated even if the display value is less than the alarm setting, this is because the alarm is activated by the value in peak memory rather than the display value.

Example 5 - **AI** is set to **Lo** and **FI/FP** is set to **Lo**

If **AILO** is set to **280** and the valley memory value becomes less than **280** then alarm 1 will be constantly activated at this point and will only become de activated when the memory is reset at a value above **280**. The memory can be reset by holding the remote input closed for 2-3 seconds. Note that in this case the alarm can be activated even if the display value is greater than the alarm setting, this is because the alarm is activated by the value in valley memory rather than the display value.

Example 1- **AI** is set to **di SP**

With the alarm function set to follow the display value the relays will operate from whatever value happens to be on the display at the time. For example if the display is toggled to the peak memory value and this peak value is above the high setpoint limit then the relay will activate even if the live input at the time is below the high setpoint limit.

Optional relays

Two alarm relays are fitted as standard. One or two extra relays are optionally available. See appropriate appendix in this manual for details of optional relays.

Switching Inductive Loads

If the alarm relay is to be used to switch an inductive load, such as a solenoid, it is advisable to use a suppressor circuit either across the load or across the relay contacts. Switching inductive loads without a suppressor circuit can cause arcing at the relay contacts resulting in electrical interference and wear on the contacts. A typical suppressor circuit consists of a 100Ω resistor in series with a 0.1uF capacitor, this circuit is then placed across the load or relay contacts. Ensure that the resistor and capacitor are of sufficiently high rating to cope with the voltage and current encountered.

7 Remote input functions

Remote input operation is via voltage free contacts on the instrument terminal block (terminals 5 and 9) shorting together these terminals will cause the selected function to operate. The remote input may be either a bi-state contact closure (toggle switch, PLC or other external switch) or a momentary or latching switch contact, depending on the function requirements. The remote input function will operate when the switch is closed e.g. for display hold the display value will be held whilst the switch is closed and will be free to follow the live input when the switch is open. The remote input may be configured to perform any **one** of the following functions:

Function	Description
<i>NONE</i>	None - this function is selected when none of the special functions are required.
<i>PHLD</i>	Peak hold - this function displays and holds the peak reading, when the contact input is closed i.e. the maximum value from the time of contact closure is displayed. When the contact is open the display indicates the live reading. A two position toggle switch would be commonly used for this function.
<i>dHLD</i>	Display hold - the display hold function is similar to peak hold, except that the held reading is the value displayed at the time the switch contact is closed. A two position toggle switch would be commonly used for this function.
<i>H_i</i>	Peak memory - the peak memory (max) is displayed when the pushbutton contact is closed momentarily i.e. the maximum display value since the last reset. The display is returned to the normal display after 20 seconds. To reset the peak memory the button must be held closed for 1 to 2 seconds. Note: the <i>H_i</i> function will be reset 5 seconds after instrument switch on i.e. the <i>H_i</i> readings will only start to be stored once 5 seconds have elapsed. The switch input for this function is usually a momentary action pushbutton switch.
<i>Lo</i>	Valley memory - the valley memory (min) operates in a similar way to the peak memory but shows the lowest display value since last reset. Note: the <i>Lo</i> function will be reset 5 seconds after instrument switch on i.e. the <i>Lo</i> readings will only start to be stored once 5 seconds have elapsed. The switch input for this function is usually a momentary action pushbutton switch.
<i>H_i Lo</i>	Peak memory/valley memory - The display may be toggled between peak and valley memory indications. i.e. press momentarily once and the message <i>H_i</i> followed by the peak memory value will be displayed, press momentarily a second time and the message <i>Lo</i> followed by the valley memory value will be displayed. The switch input for this function is usually a momentary action pushbutton switch.
<i>SP.Ac</i>	Setpoint access only - allows access to the selected (via the <i>SPAC</i> function) alarm set points only, no other functions, when key switch is open. Allows full access with the key switch/remote input closed. A two position toggle switch or key switch would be commonly used for this function.
<i>no.Ac</i>	No program access - inhibits access to functions via keypads. The remote input requires a contact closure (short circuit) to allow access to functions. A two position toggle switch or key switch would be commonly used for this function.
<i>CAL.S</i>	Select calibration - one set of calibrations can be performed with the switch open and a second set with the switch closed. The remote input can then be used to switch between these two separate calibration memories. When the external input is open one set will be displayed and when the switch is closed the next calibration set will be used. This function may be used to select different input types, different scale values etc. In addition to the calibration scaling the following functions can be given different settings in each of the calibration position: display rounding (<i>drnd</i>), decimal point (<i>dCPE</i>), input type (<i>INPT TYPE</i>), degree type (<i>DEG TYPE</i>), display units (<i>di SP units</i>) and for mV direct inputs the number of linearisation points (<i>LinPTS</i>) can also be changed. A two position toggle switch would be commonly used for this function.

dull	Dull - when the remote input is set to dull the remote input can be used to switch between the display brightness level set by the brgt function and the display brightness set by the dull function. The display brightness is selectable from 0 to 15 , where 0 = lowest intensity (display off) and 15 = highest intensity. This function is useful in reducing glare when the display needs to be viewed in both light and dark ambient light levels and for reducing power consumption in battery powered applications. A two position toggle switch would be commonly used for this function.
-------------	--

Selecting the remote input function

To select the required function, enter **CR** mode in the usual way (see “Explanation of functions” chapter) and step through the functions until you reach the remote input indicated by the display message **F: RP** followed by the selected function. Use the **▲** and **▼** buttons to select the required function.

A single point calibration scaling method (**CAL DEG**) may be used on RTD or thermocouple input types to scale the display. For direct mV inputs two to five points can be used to scale the display. Note that access to calibration functions will require entry via **CAL** mode (see chapter 4 for details of **CAL** mode entry) unless the access function (**ACCESS**) is set to **ALL**. If any error messages are seen during calibration consult section 4.1. If errors occur during calibration leading to inaccurate readings the instrument can be reset to factory default scaling via the **UCAL** function.

CAL DEG (temperature scaling for RTDs & thermocouples)

CAL DEG is used to scale the instruments display to the correct temperature. This procedure is only required when an adjustment needs to be made to the temperature reading. When using this method a signal input from the temperature sensor or simulator must be present at the input terminals.

The procedure for entering the scaling point is:

- a. Place the sensor at a known temperature, alternatively a RTD or thermocouple simulator can be used. Note that thermocouples require a high temperature for calibration, the exact temperature depends on the thermocouple type but it must be at least 10% of the specified maximum temperature range for the type of thermocouple used, see "Specifications" for thermocouple ranges.
- b. Enter functions via **CAL** mode, step through the functions by pressing and releasing the **F** button and at the **CAL DEG** function press **▲** and **▼** simultaneously then release them. The display will indicate the live input value. Do not be concerned at this stage if the live input display value is not what is required. It is important that the live input value seen is a steady value, if not then the input needs to be investigated before proceeding with the scaling.
- c. Press, then release the **F** button. The display will indicate **SEL 1** followed by a value. Use the **▲** or **▼** button to change this value to the required display value at this input. Press the **F** button to accept changes or the **P** button to abort the scaling.

CAL 1, CAL 2 etc. (display scaling for direct mV inputs)

This method uses two, three, four or five different live input mV signals to calibrate the instrument. Using more than two points allows the display to be scaled to follow a linearisation curve. If two points are used the display will be linear. The process is as follows:

1. Step through the functions until the display indicates **L, n Pts** and use the **▲** or **▼** keypad to select the number of calibration scaling points required.
2. Step through the functions until the display indicates **CAL 1**. Now press, then release, the **▲** and **▼** buttons simultaneously to enter the calibration functions. The display will now indicate **CAL 1** (1st calibration point) followed by a "live" reading. Apply a known input to the instrument of nominally 0mV (this value is not critical and may be anywhere within the measuring range of the instrument). When the live reading has stabilised press the **F** button.
3. The display will indicate **SEL 1** (scale 1) followed by the scale value in memory. Now use the **▲** or **▼** button to obtain the required scale value.
4. Press the **F** button, the display will now indicate **CAL End** (indicating that calibration of the first point is complete).
5. The display will now indicate **CAL 2** (2nd calibration point). If you do not wish to enter the second point at this stage then press and release the **F** button until the **FUNC End** message is seen. If you wish to enter the second point at this stage press the **▲** and **▼** buttons simultaneously.
6. The display will now indicate **CAL 2** (2nd calibration point) followed by a "live" reading. Apply an input greater than that used for **CAL 1** (again this value is not critical but it should be at least 10% of full input range different to the **CAL 1** input. For best accuracy the input should be as close to full capacity as possible).
7. When the reading has stabilised, press the **F** button, the display will now read **SEL 2** (scale 2) followed by the second scale value in memory. Use the **▲** or **▼** button to obtain the required scale value. Press the **F** button, the display will now read **CAL End** (indicating that calibration of the second point is complete).
8. Repeat the process for the remaining calibration points (**CAL 3, CAL 4** etc).

Example - Scaling using three linearisation points

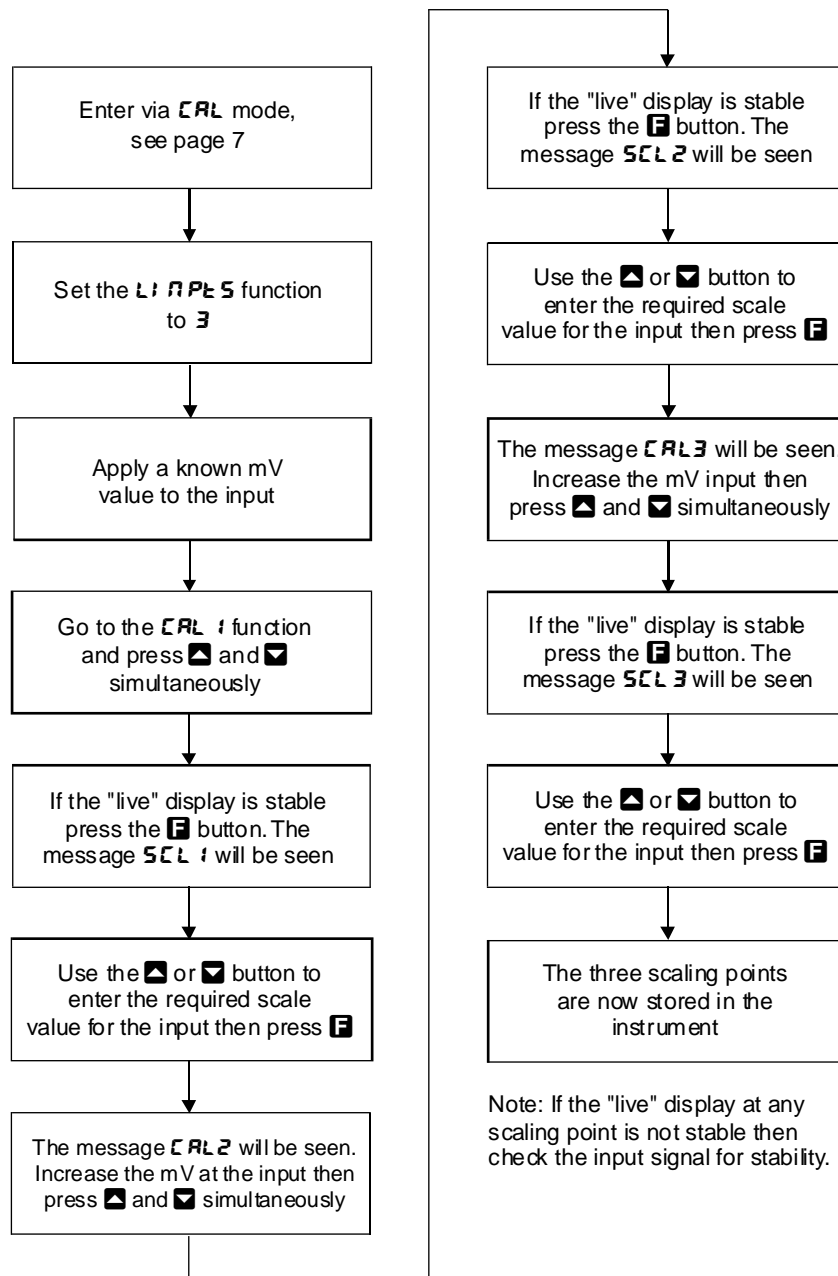

UCAL (uncalibration)

Used to set the instrument back to the factory calibration values. This function should only be used when calibration problems exist, and it is necessary to clear the calibration memory. To clear the memory press the [▲] and [▼] buttons simultaneously at the UCAL functions. The message CAL CLR will be seen to indicate that the memory has cleared.

Returning to the normal measure mode

When the calibration procedure has been completed it is advisable to return the instrument to the normal mode (where calibration functions cannot be tampered with). To return to the normal mode, turn off power to the instrument, wait a few seconds and then restore power.

9 Setting up the relay PI controller

The Relay Proportional + Integral Controller can be made to operate in either pulse width control or frequency control mode via the **Rx OPEF** function. The best results are usually achieved by initially configuring as a “Proportional Only” controller and then introducing the Integral function when stable results are obtained.

The “x” in the **Rx OPEF** and other functions indicates the chosen relay i.e. for relay 1 the display will show **R1 OPEF**, **R1 ISP** etc. The **Rx OPEF** function allows three choices of operating mode for the chosen relay, namely **Rx RL**, **Rx EP** and **Rx FR**. If **Rx RL** is selected the chosen relay will operate as a setpoint relay whose operation is controlled by the **RxLo**, **RxHi**, etc. settings and is not affected by any of the PI control settings. See the “Explanation of functions” chapter for details of operation when **Rx RL** is selected. If **Rx EP** is selected then the chosen relay will operate in pulse width control mode. If **Rx FR** is selected then the chosen relay will operate in the frequency control mode.

Pulse width control operates by controlling the on to off time ratio of the relay. In a typical application this would be used to control the length of time for which a dosing pump is switched on during a control cycle i.e. the pump or other device will continuously dose for the length of time the relay is activated and will stop dosing when the relay is de-activated.

Frequency control operates by changing the rate at which the relay switches on and off. In a typical control application the frequency control operation is particularly suited for use when one shot dosing is used i.e. the pump or other device puts out a fixed dosing quantity for every pulse received.

Pulse width modulation control mode

To use pulse width modulation control **Rx EP** must be selected at the **Rx OPEF** function.

Pulse width control

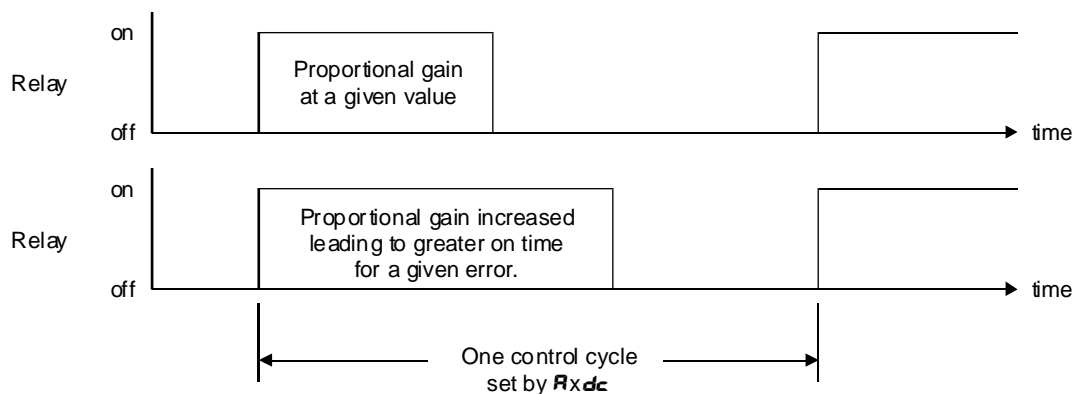

RxSP (control setpoint)

The control setpoint is set to the value in displayed engineering units required for control of the process. The controller will attempt to vary the control output to keep the process variable at the setpoint.

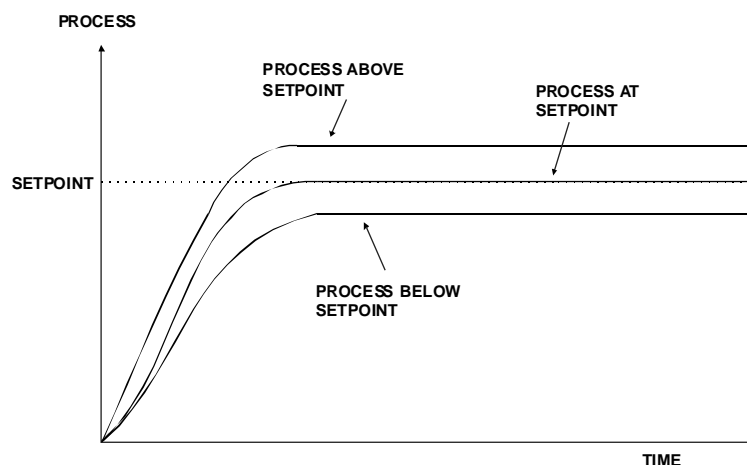

ctrl SPAN (proportional control span)

The function of the control span is to define the limit to which the proportional control values will relate. The control span value will be common to all control relays i.e. if more than one control relay output is being used then each of these relays operates from the same control span setting. The span value defines the range over which the input must change to cause a 100% change in the control output when the proportional gain is set to 1.000. This function affects the overall gain of the controller and is normally set to the process value limits that the controller requires for normal operation. For example if the control setpoint (AxSP) is 70.0 and the ctrl SPAN is 20.0 then an error of 20 degrees from the setpoint will cause a 100% change in proportional control output. For example with AxSP at 70.0, ctrl SPAN at 20.0, AxPG at 1.000 and AbS at 0.000 a display reading of 50.0 or lower (AxSP minus ctrl SPAN) the control output will be at 100% i.e. the relay will be on continuously. The control output will then gradually adjust the on/off time as the display value reaches the setpoint.

AxPG (proportional gain)

The proportional value will determine the degree to which the controller will respond when there is a difference (error) between the measured value and the process setpoint. If the proportional gain is increased then for a given error the relay frequency will be increased i.e. the period of the control cycle will be decreased. The proportional gain action can be reversed by setting a negative gain i.e. with a negative gain the frequency will reduce as the error increases. With a proportional gain of 1.000 and an error of 10 or more (with control gain set at 10) the controller will increase the frequency by 100% if possible. With a proportional gain of 0.500 an error of 10 or more (with control gain set at 10) will cause the controller to increase the frequency by 50%, if possible.

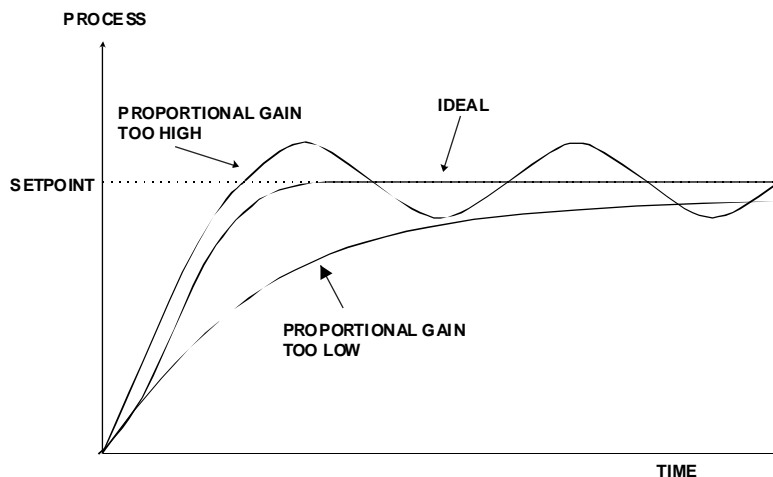

Too much proportional gain will result in instability due to excessive overshoot of the setpoint. Too little proportional gain will lead to a slow response.

AxI 9 (integral gain)

The Integral action will attempt to correct for any offset which the proportional control action is unable to correct (e.g. errors caused by changes in the process load). When the integral gain is correctly adjusted the control output is varied to maintain control by keeping the process variable at the same value as the control setpoint. Since the integral gain is time based the output will gradually increase if the error does not decrease i.e. if the measured value remains constant and there is an error (a difference between the measured value and the setpoint) then the frequency will be increased compared to the previous frequency output. The higher the proportional gain, the greater the degree by which the on to off ratio will be affected i.e. the response will be greater at higher integral gain settings. With an integral gain of 1.000 an error of 10 or more (with control span set at 10) will cause the integral action to try to correct at the rate of 100%/minute. With an integral gain of 0.200 an error of 10 or more will cause the integral action to try to correct at the rate of 20%/minute.

Too high an integral gain will result in instability. To low an integral gain will slow down the time taken to reach the setpoint. The optimum setting will depend on the lag time of the process and the other control settings. Start with a low figure (e.g. 0.200) and increase until a satisfactory response time is reached. The integral gain figure has units of gain/minute and may be set in the range of approx. 32.000 to -32.000. Note that a display with more than 5 digits is required to show -32.000. The integral action can be reversed by setting a negative gain figure, note that the sign of the integral gain must match the sign of the proportional gain.

The integral control output follows the formula:

$$\text{Integral control output} = \frac{\text{error} \times \text{Ig} \times \text{time (secs)}}{60} + \text{previous integral control output}$$

Where Ig is the integral gain set via **RxI 9**.

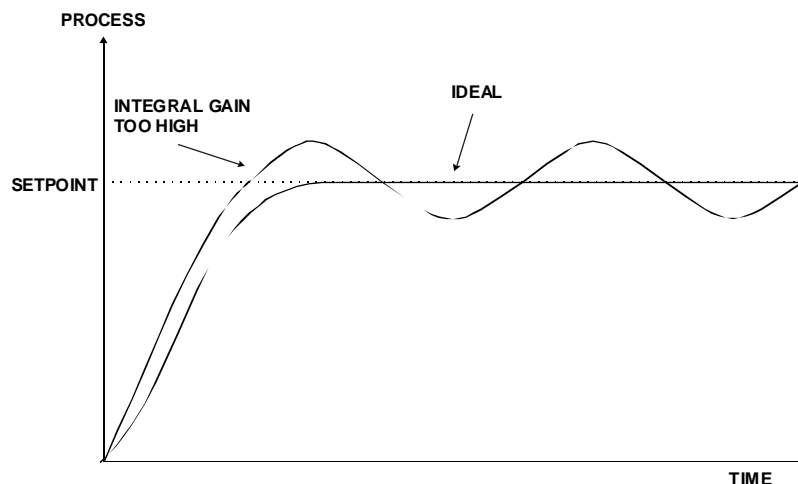

RxI L (minimum limit of integral term)

The minimum limit can be used to reduce overshoot of the control setpoint when the control output is being reduced i.e. falling below the setpoint. The low limit reduces the available output swing by a percentage of the maximum output. Without a limit the integral output can be very large at the time the setpoint is reached and a large overshoot of the will then result. Settings available are from 0.0 to 100.0 (%). If the limit setting is too high then overshoot will result. If the setting is too low then the integral output can be limited to such an extent that the setpoint cannot be maintained. Start with a low value such as 20.0 and increase or decrease the value until a satisfactory result is obtained. The advantage of using separate low and high limits is that in many applications the response is very one directional e.g. the system may respond very quickly to a heat input but may cool down at a much slower rate. Separate high and low limit settings allow independent limiting of the integral control swing below and above the setpoint so a smaller minimum limit can be set to limit swings below the setpoint to compensate for the slower cooling time.

The minimum and maximum limits are used in conjunction with the output bias setting to maintain the control process setpoint value. For example with a bias (**Rxb5**) set at 50%, minimum limit (**RxI L**) set at 20% and a maximum limit of 30% the actual bias when the process is at the setpoint may be anywhere between 30% and 80% i.e. Integral control is being used to alter the bias setting in order to maintain the process at the setpoint. In this case the minimum term will allow the bias to drop to a value between 50% and 30% in order to maintain the setpoint. The maximum term will allow the bias point to rise to a value between 50% and 80% in order to maintain the setpoint.

RxI H (maximum limit of integral term)

The maximum limit can be used to reduce overshoot of the control setpoint when the control output is increasing i.e. rising above the setpoint. Other than this the limit operates in the same manner as the low limit described previously.

Rxb5 (control output bias)

The control bias sets the ideal steady state output required once the setpoint is reached. Settings are in % from 0.0 to 100.0. When set at 0.0 the relay will be de-activated for the entire control period when the measured input is at the setpoint (depending on proportional and integral gain settings). If set at 50.0 then the relay operation frequency will on for 50% and off for 50% of the duty cycle time when the measured input is at the setpoint. If set at 100.0 then the relay will activated for the whole time whilst the measured input is at the setpoint.

RxdC (control cycle period)

Displays and sets the control period cycle from 0 to 250 seconds. The control period sets the total time for each on/off cycle. This time should be set as long as possible to reduce wear of the control relay and the controlling device.

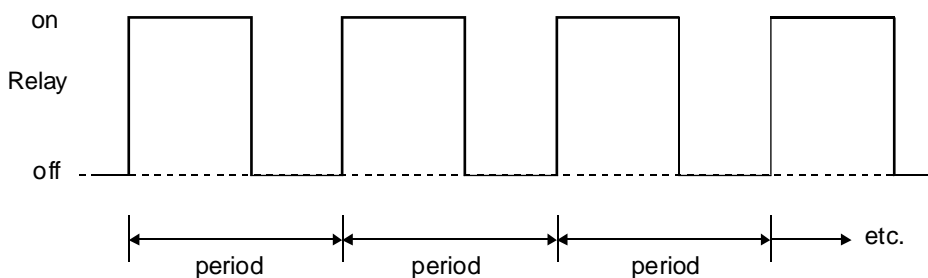

Setting up the pulse width controller

1. Set the **Rx OPEF** function to **RxLP**.
2. Set the control setpoint **RxSP** to the required setting.
3. Set the control span **ctrl: SPAN** to the required setting.
4. Set the proportional gain **RxP9** to an arbitrary value e.g. **0.500**.
5. Set the integral gain **Rxi 9** to **0.000** (i.e. off).
6. Set the low and high integral **Rxi L** and **Rxi H** limits to an arbitrary value e.g. **20.00**.
7. Set the bias **Rxb5** to **50.0**.
8. Set the cycle **RxdC** period to 60 seconds.

Initialise the control system and monitor the control results. If the original settings causes process oscillations then gradually decrease the proportional gain until the oscillations decrease to an acceptable steady cycle. If the original settings do not cause process oscillations then gradually increase the proportional gain until a steady process cycling is observed.

Once the steady cycling state is achieved note the difference between the display value and the control setpoint value. Gradually increase or decrease the bias value until the displayed value matches (or cycles about) the control setpoint value.

Gradually increase the integral gain until the process begins to oscillate. Then reduce the integral gain slightly to regain the control without this added oscillation.

Create a step change to the process conditions and observe the control results. It may be necessary to fine tune the settings and use integral limits to obtain optimum results.

Set up sequence	Symptom	Solution
Proportional gain	Slow response	Increase Proportional gain
	High overshoot or oscillations	Decrease Proportional gain
Proportional bias	Process above or below control setpoint	Increase or decrease bias as required
Integral gain	Slow response	Increase Integral gain
	Instability or oscillations	Decrease Integral gain

Frequency modulation control mode

To use pulse width modulation control **Ax.Fr** must be selected at the **Ax OPEF** function.

Frequency control

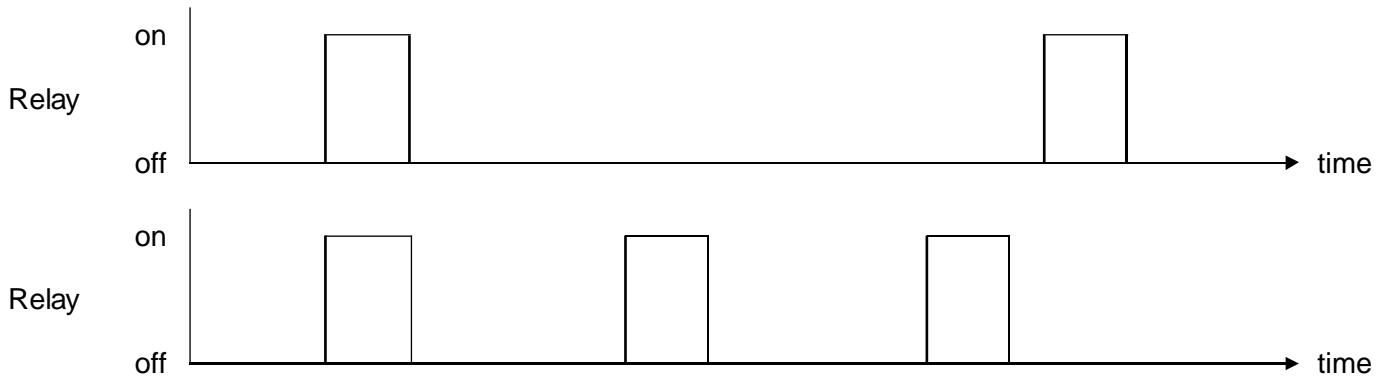

In frequency modulation mode the relay on time is fixed. A minimum relay off time can also be set. The control program will vary the actual off time to suit the error seen between the setpoint and the measured temperature at the time. For example if extra dosing is needed to reach the setpoint then the off time will be reduced resulting in more on pulses per period of time i.e. the frequency of the pulses is controlled to allow the setpoint to be maintained.

AxSP (control setpoint)

The control setpoint is set to the value in displayed engineering units required for control of the process. The controller will attempt to vary the control output to keep the process variable at the setpoint.

Ctrl: SPAN (proportional control span)

The function of the control span is to define the limit to which the proportional control values will relate. The control span value will be common to all control relays i.e. if more than one control relay output is being used then each of these relays operates from the same control span setting. The span value defines the range over which the input must change to cause a 100% change in the control output when the proportional gain is set to 1.000. This function affects the overall gain of the controller and is normally set to the process value limits that the controller requires for normal operation. For example if the control setpoint (**AxSP**) is 70.0 and the **Ctrl: SPAN** is 20.0 then an error of 20 degrees from the setpoint will cause a 100% change in proportional control output. For example with **AxSP** at 70.0, **Ctrl: SPAN** at 20.0, **AxPG** at 1.000 and **AxBS** at 0.000 a display reading of 66.0 or lower (**AxSP** minus **Ctrl: SPAN**) the control output will be at 100% i.e. the relay will be at its maximum frequency, this frequency will be determined by the **Axdr** and **Axdc** functions. The control output will then gradually adjust the off time as the display value reaches the setpoint.

AxPG (proportional gain)

The proportional value will determine the degree to which the controller will respond when there is a difference (error) between the measured value and the process setpoint. If the proportional gain is increased then for a given error the relay frequency will be increased i.e. the period of the control cycle will be decreased. The proportional gain action can be reversed by setting a negative gain i.e. with a negative gain the frequency will reduce as the error increases. With a proportional gain of 1.000 and an error of 10 or more (with control gain set at 10) the controller will increase the frequency by 100% if possible. With a proportional gain of 0.500 an error of 10 or more (with control gain set at 10) will cause the controller to increase the frequency by 50%, if possible.

Too much proportional gain will result in instability due to excessive overshoot of the setpoint. Too little proportional gain will lead to a slow response.

Axi I (integral gain)

The Integral action will attempt to correct for any offset which the proportional control action is unable to correct (e.g. errors caused by changes in the process load). When the integral gain is correctly adjusted the control output is varied to maintain control by keeping the process variable at the same value as the control setpoint. Since the integral gain is time based the output will gradually increase if the error does not decrease i.e. if the measured value remains constant and there is an error (a difference between the

measured value and the setpoint) then the frequency will be increased compared to the previous frequency output. The higher the proportional gain, the greater the degree by which the on to off ratio will be affected i.e. the response will be greater at higher integral gain settings. With an integral gain of 1.000 an error of 10 or more (with control span set at 10) will cause the integral action to try to correct at the rate of 100%/minute. With an integral gain of 0.200 an error of 10 or more will cause the integral action to try to correct at the rate of 20%/minute.

Too high an integral gain will result in instability. To low an integral gain will slow down the time taken to reach the setpoint. The optimum setting will depend on the lag time of the process and the other control settings. Start with a low figure (e.g. 0.200) and increase until a satisfactory response time is reached. The integral gain figure has units of gain/minute and may be set in the range of approx. 32.000 to -32.000. Note that a display with more than 5 digits is required to show **-32.000**. The integral action can be reversed by setting a negative gain figure, note that the sign of the integral gain must match the sign of the proportional gain.

The integral control output follows the formula:

$$\text{Integral control output} = \frac{\text{error} \times \text{Ig} \times \text{time(secs)}}{60} + \text{previous integral control output}$$

Where Ig is the integral gain set via **RxI 9**.

RxI 4 (minimum limit of integral term)

The minimum limit can be used to reduce overshoot of the control setpoint when the control output is being reduced i.e. falling below the setpoint. The low limit reduces the available output swing by a percentage of the maximum output. Without a limit the integral output can be very large at the time the setpoint is reached and a large overshoot of the will then result. Settings available are from 0.0 to 100.0 (%). If the limit setting is too high then overshoot will result. If the setting is too low then the integral output can be limited to such an extent that the setpoint cannot be maintained. Start with a low value such as 20.0 and increase or decrease the value until a satisfactory result is obtained. The advantage of using separate low and high limits is that in many applications the response is very one directional e.g. the system may respond very quickly to a increasing but the system may take a long time to recover if the temperature setpoint is overshoot. Separate high and low limit settings allow independent limiting of the integral control swing below and above the setpoint.

RxI 8 (maximum limit of integral term)

The maximum limit can be used to reduce overshoot of the control setpoint when the control output is increasing i.e. rising above the setpoint. Other than this the limit operates in the same manner as the low limit described previously.

Rxb5 (control output bias)

The control bias sets the ideal steady state output required once the setpoint is reached. Settings are in % from 0.0 to 100.0. When set at 0.0 the relay will be de-activated for the entire control period when the measured input is at the setpoint (depending on proportional and integral gain settings). If set at 50.0 then the relay operation frequency will be lower then the maximum when the measured input is at the setpoint. If set at 100.0 then the relay will be at its maximum frequency when the measured input is at the setpoint.

Rxdc (control relay minimum off time)

Displays and sets the control relay minimum off time from 0 to 250 seconds. If set to 0 the relay will be disabled. This time should be set as long as possible to reduce wear of the control relay and the controlling device. The control program can extend the off time to maintain the setpoint but not reduce it.

If a 100% error is seen then the pulse rate will be at its maximum i.e. the off time will equal **Rxdc**. If a 50% error is seen there will be a pulse every 2 times **Rxdc**. For a 25% error there will be a pulse every 4 times **Rxdc** and for a 10% error there will be a pulse every 10 times **Rxdc**.

Rxdr (control relay on duration)

Displays and sets the control relay on duration from 0.0 to 25.0 seconds. If set to 0.0 the relay will be disabled. The duration should be long enough to ensure that the device being controlled receives an acceptable on pulse.

Setting up the frequency controller

1. Set the **Ax OPEF** function to **AxFr**
2. Set the control setpoint **AxSP** to the required setting.
3. Set the control span **AxSPAN** to the required setting.
4. Set the proportional gain to an arbitrary value e.g. **0.500**
5. Set the integral gain to **0.000** (i.e. off).
6. Set the high and low integral limits **AxI L** and **AxI H** to an arbitrary value e.g. **20.00**
7. Set the bias **AxbS** to **50.0**.
8. Set the minimum off time **Axdc** to **20**.
9. Set the relay on time **Axdr** to an arbitrary value e.g. **1.0**

Initialise the control system and monitor the control results. If the original settings causes process oscillations then gradually decrease the proportional gain until the oscillations decrease to an acceptable steady cycle. If the original settings do not cause process oscillations then gradually increase the proportional gain until a steady process cycling is observed.

Once the steady cycling state is achieved note the difference between the display value and the control setpoint value. Gradually increase or decrease the bias value until the displayed value matches (or cycles about) the control setpoint value.

Gradually increase the integral gain until the process begins to oscillate. Then reduce the integral gain slightly to regain the control without this added oscillation.

Create a step change to the process conditions and observe the control results. It may be necessary to fine tune the settings and use integral limits to obtain optimum results.

Set up sequence	Symptom	Solution
Proportional gain	Slow response	Increase Proportional gain
	High overshoot or oscillations	Decrease Proportional gain
Proportional bias	Process above or below control setpoint	Increase or decrease bias as required
Integral gain	Slow response	Increase Integral gain
	Instability or oscillations	Decrease Integral gain

10 Specifications

10.1 Technical Specifications

Input Types:	100Ω RTD (Pt100), 1000Ω RTD (Pt1000) or thermocouple type B, E, J, K, N, R, S or T (selectable) or direct mV input ±20mV, ±50mV, ±75mV or ±200mV ranges
Measuring range:	100Ω (-180 to 650°C), 1000Ω (-180 to 550°C), type B (400 to 1866°C), type E (-100 to 1000°C), type J (-100 to 870°C), type K (-100 to 1372°C), type N (-100 to 1300°C), type R (-35 to 1768°C), type S (-35 to 1768°C), type T (-100 to 400°C) 20mV (-20 to +20mV), 50mV (-50 to +50mV), 75mV (will measure from -98 to +98V approx.)
Display values:	Temperature °F or °C or scaled in engineering units for mV input
ADC resolution:	1 in 20,000
Display resolution:	RTD & thermocouple up to 2 decimal places, mV up to 4 decimal places
Accuracy:	0.1% when calibrated
Sample rate:	4-20mA & mV 7.5 per sec., RTD 2 per sec. thermocouple 1 per sec.
Conversion:	Dual Slope ADC
Microprocessor:	MC68HC11 HCMOS
Ambient temp:	-10 to 60°C
Humidity:	5 to 95% non condensing
Display:	LED 5 digit 7.6mm + alarm annunciator LEDs
Power supply:	AC 240V, 110V, 32V or 24V 50/60Hz. DC 12 to 48V wide range (supply type is factory configured)
Power consumption:	AC supply 6VA max, DC supply 6W max. (depends on load & options)
Output (standard):	2 x relays, form A rated 5A resistive 240VAC. Configurable as alarm or PI control (frequency or time period)
Relay action:	Programmable N.O. or N.C.

10.2 Output Options

Third relay:	Rated 0.5A resistive at 30VAC or DC, form A. If no other options are fitted the third relay can be factory configured as form C. Third relay is not configurable for PI control
Fourth relay:	Rated 0.5A resistive at 30VAC or DC, form A. Fourth relay is not configurable for PI control
Transmitter supply:	Isolated & regulated 12VDC @ 50mA or 24VDC @ 25mA (link selectable)
Switched voltage:	Non isolated 24VDC output to be used for open collector or solid state relay driver
Analog output:	Isolated 4-20mA. 0-1V or 0-10V link selectable. 12 bit or 16 bit resolution versions available. Dual channel 12 bit version available. Single channel versions can be configured as retransmission or PI control. Dual channel versions can have channel 1 configured as retransmission or PI control, channel 2 is retransmission only
Serial communications:	Isolated RS232, RS485 or RS422 (factory configured)
Date/time stamp:	Internal clock provides date/time output with reading (serial comms. option required for this option)

10.3 Physical Characteristics

Case size:	44mm x 91mm x 141mm
Connections:	Plug in screw terminals. Max 2.5mm ² wire (relays and supply), 1.5mm ² wire for input and options
Weight:	500 gms basic model, 550 gms with option card

11 Guarantee & Service

The product supplied with this manual is guaranteed against faulty workmanship for a period of 2 years from the date of dispatch.

Our obligation assumed under this guarantee is limited to the replacement of parts which, by our examination, are proved to be defective and have not been misused, carelessly handled, defaced or damaged due to incorrect installation. This guarantee is VOID where the unit has been opened, tampered with or if repairs have been made or attempted by anyone except an authorised representative of the manufacturing company.

Products for attention under guarantee (unless otherwise agreed) **must be returned to the manufacturer freight paid** and, if accepted for free repair, will be returned to the customers address in Australia free of charge.

When returning the product for service or repair a full description of the fault and the mode of operation used when the product failed must be given.

In any event the manufacturer has no other obligation or liability beyond replacement or repair of this product.

Modifications may be made to any existing or future models of the unit as it may deem necessary without incurring any obligation to incorporate such modifications in units previously sold or to which this guarantee may relate.

**This document is the property of
the instrument manufacturer
and may not be reproduced in whole or part without the
written consent of the manufacturer.**

This product is designed and manufactured in Australia.