

RM4-BC

DIN Rail Mount
BCD to SSI Converter



1 Introduction

This manual addendum contains information for the installation of the RM4-BC BCD input to SSI (synchronous serial interface) output converter. The RM4-BC converter is designed to be used with model PM4-SSI, RM4-SSI or LD-SS display units. All setup takes place at the display unit other than internal link & resistor pack setting. RM4-BC versions allowing up to 8 bits or up to 24 bits are available.

BCD, strobe and address input signal may be of the voltage free type or signal voltages up to 48VDC. See "Electrical installation" chapter for resistor pack requirements for various input voltage levels.

The RM4-BC is a DIN rail mounting module and clips easily onto standard rails 35mm rails (EN50022).

Plug in electrical connections simplify installation and removal for service. The plug in terminals accept wires of up to 1.5mm² or 2.5mm² for power supply connections.

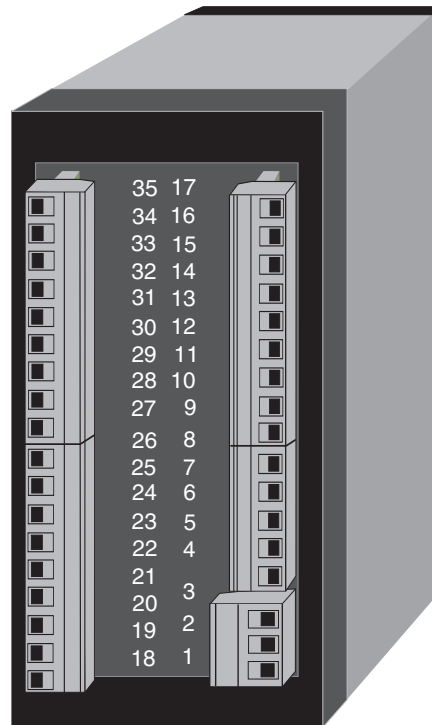

The BCD data address and strobe inputs correspond to display digits as shown below. i.e. digit 1 is the right most display digit which is the least significant digit.



2 Mechanical installation

The dimensions of the RM4-BC are shown in the diagram below. The RM4-BC is designed for DIN rail, vertical mounting. The instrument snaps onto 35mm DIN standard rails (EN50022). To install the unit simply clip onto the rail shown below. To remove lever the lower arm downwards as illustrated below

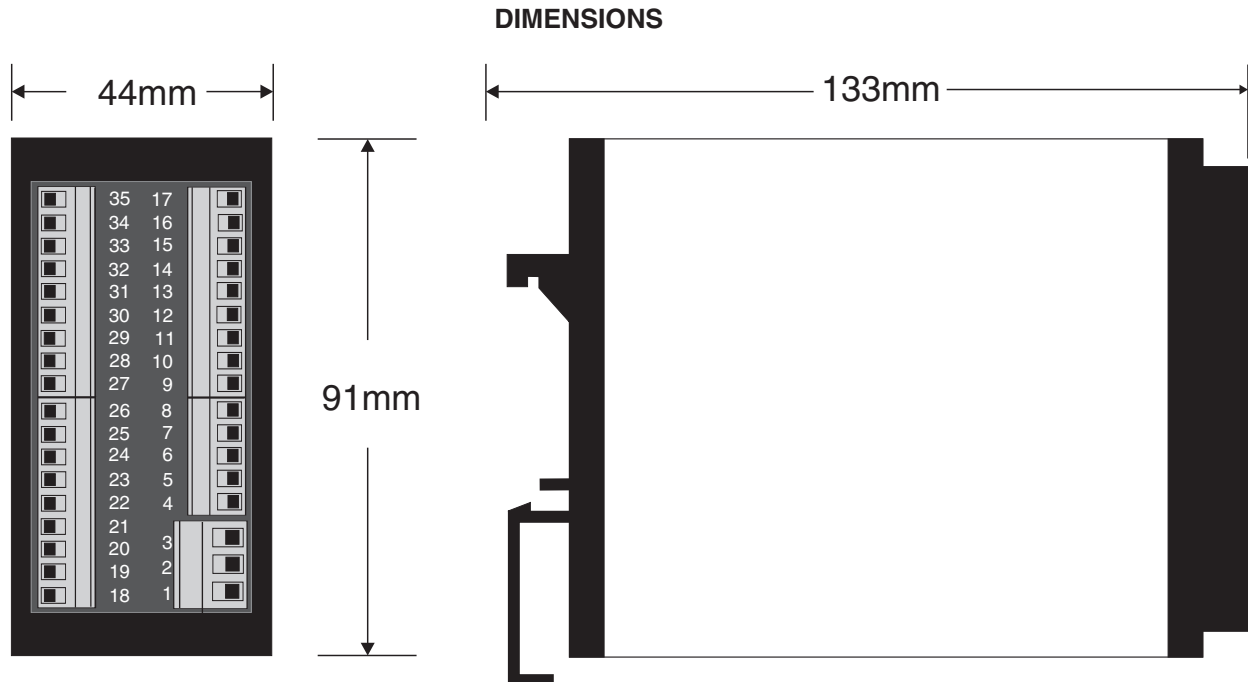

CLIPPING THE INSTRUMENT ONTO THE DIN RAIL AND REMOVAL FROM THE DIN RAIL

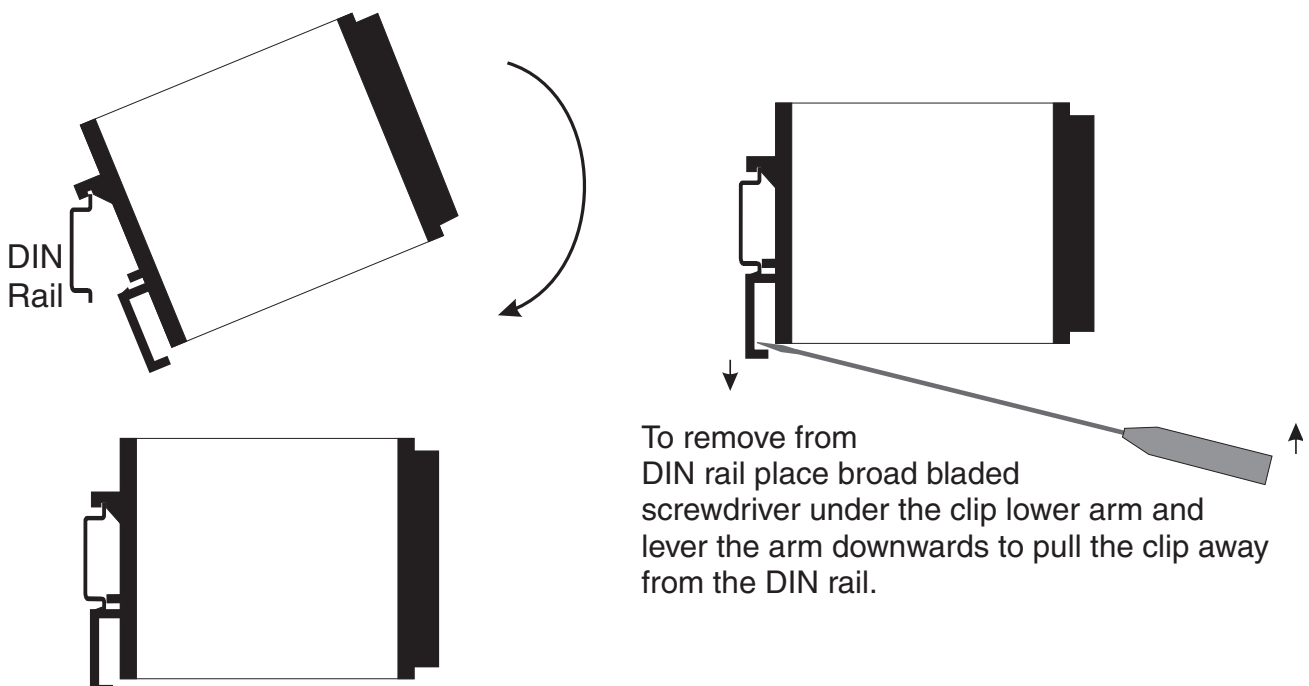

3 Electrical Installation

The RM4 Rail Mount Process Module is designed for continuous operation and no power switch is fitted to the unit. It is recommended that an external switch and fuse be provided to allow the unit to be removed for servicing. The terminal blocks allow for wires of up to 1.5mm² to be fitted (2.5mm² for power connections).

3.1 Model SS8 parallel input connections

Display unit main settings *SEt 1 NPt = bcd . 1 NPt = PARL . SEt OPER = bc 8*

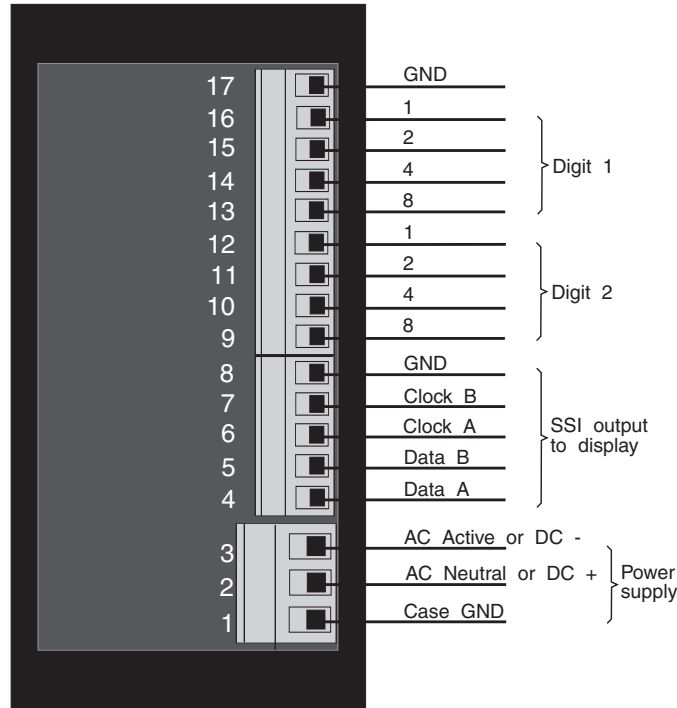

Input circuit *bc 8* parallel mode connection

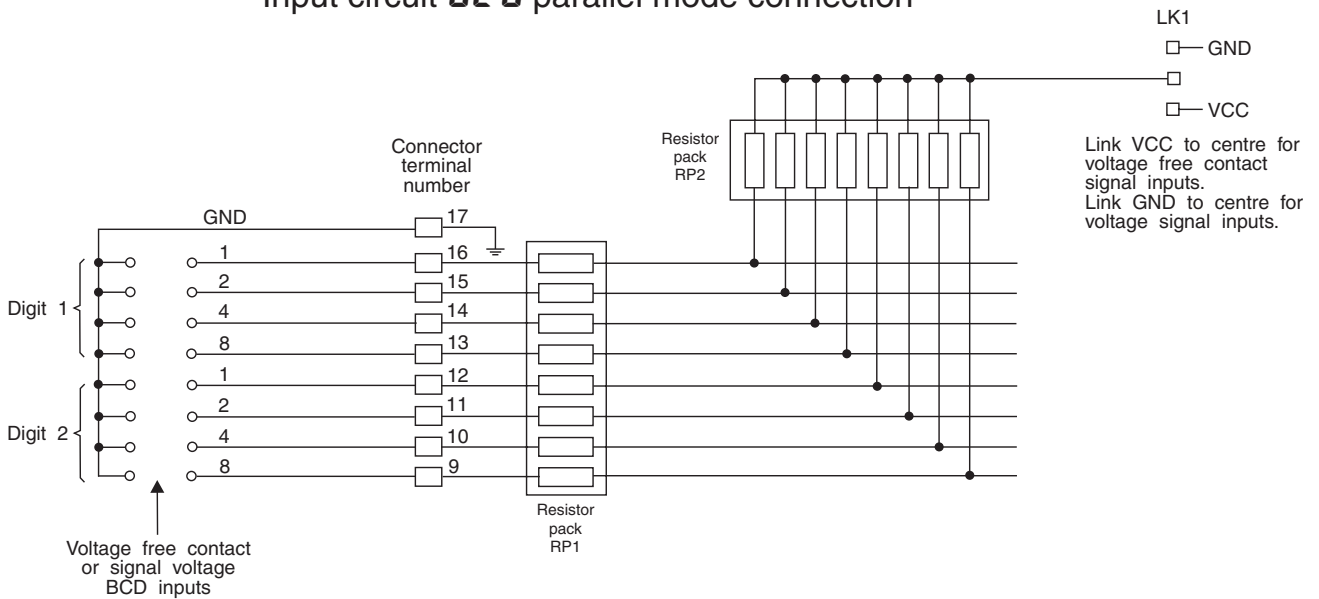

3.2 Model SS8 strobed input connections

Display unit main settings $SEt NPt = bcd ; NPt = Strb ; SEt OPEr = bcB$

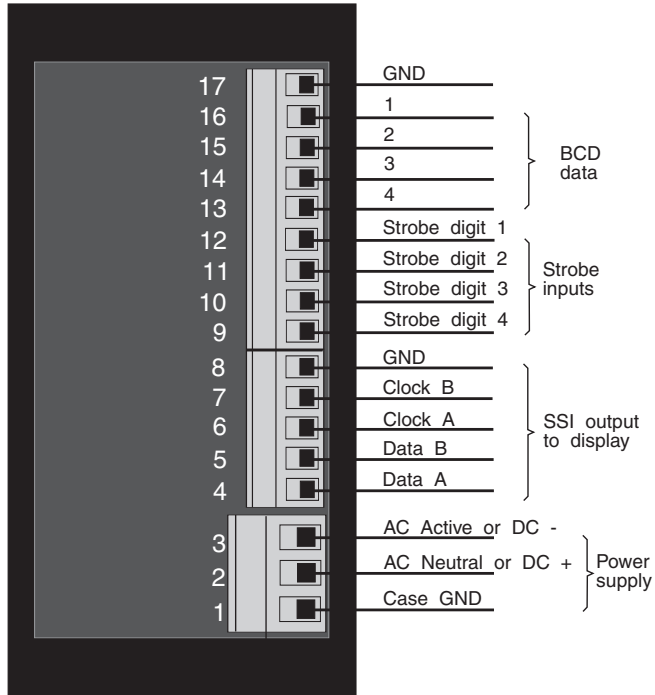

Input circuit bcB strobed mode connection

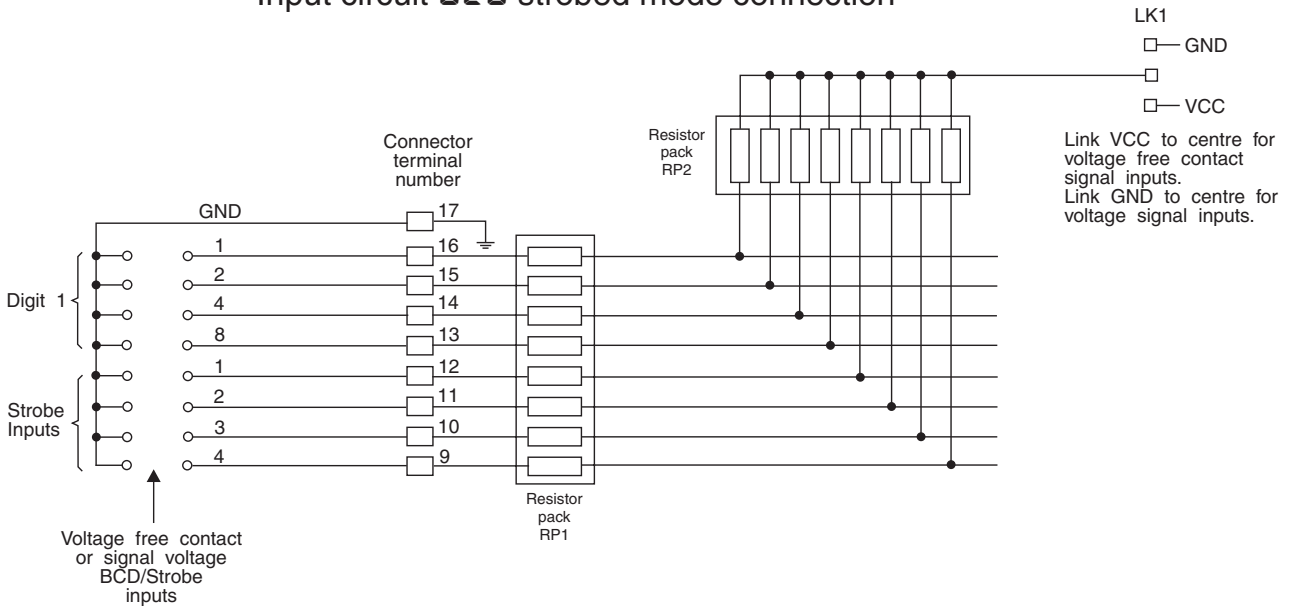

Strobe mode operation:

1. Set data value
2. Activate required strobe input when ready

3.3 Model SS8 addressed input connections

Display unit main settings **SEt NPt = bcd ; NPt = Addr . SEt OPEr = bc 8**

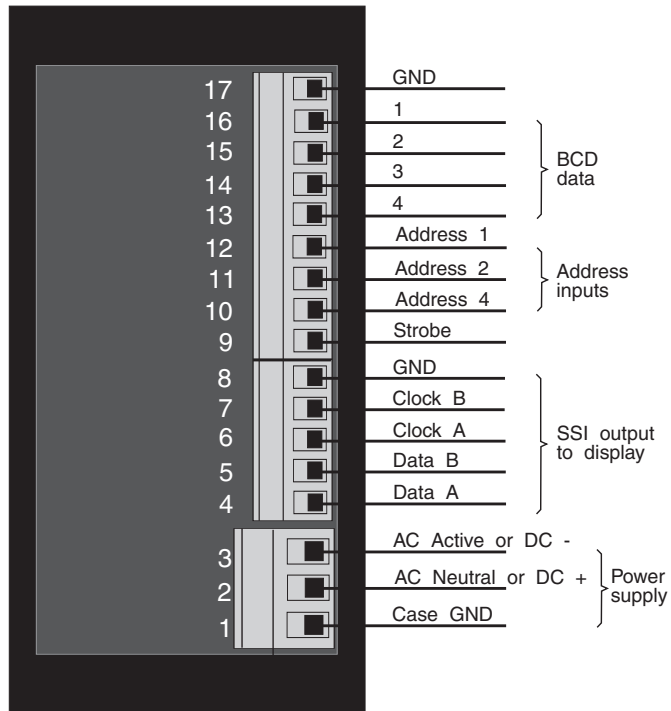

Input circuit **bc 8** addressed mode connection

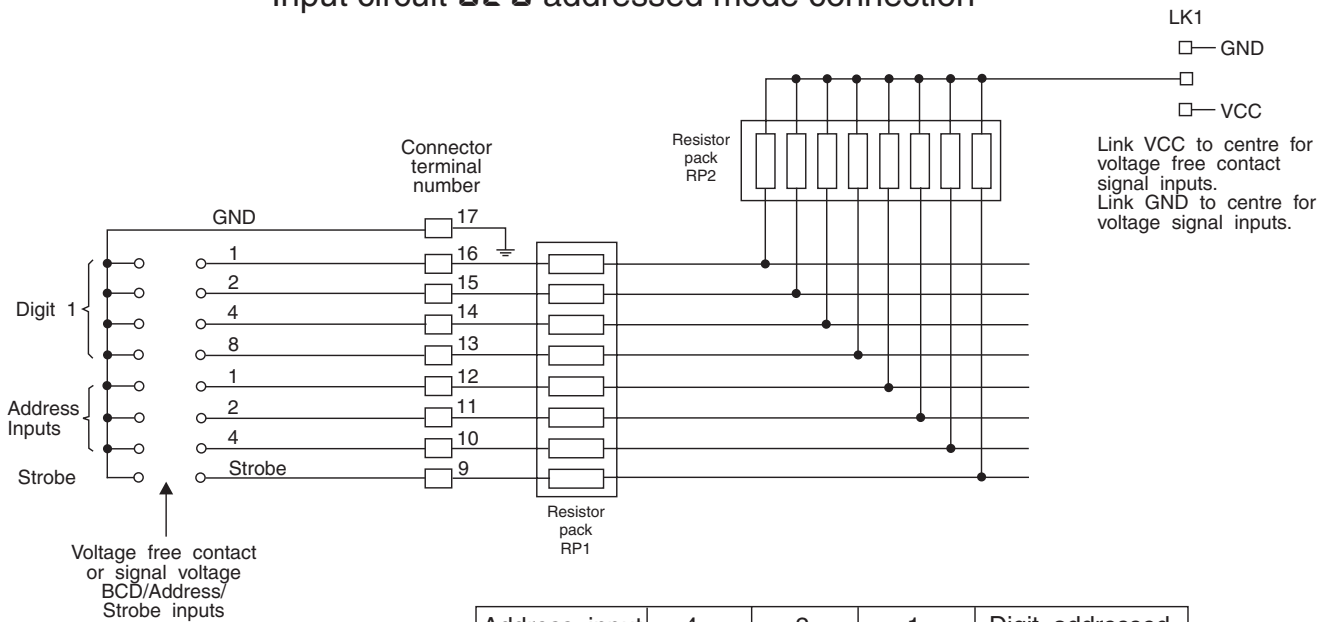

Addressed mode operation:

1. Set data value
2. Set address
3. Activate strobe input when ready

Address input	4	2	1	Digit addressed
Status	Inactive	Inactive	Inactive	1
	Inactive	Inactive	Active	2
	Inactive	Active	Inactive	3
	Inactive	Active	Active	4
	Active	Inactive	Inactive	5
	Active	Inactive	Active	6
	Active	Active	Inactive	7
	Active	Active	Active	8

3.4 Model SS24 parallel input connections

Display unit main settings *SEt 1 NPt = bcd.1 NPt = PARL. SEt OPEr = bc 24*

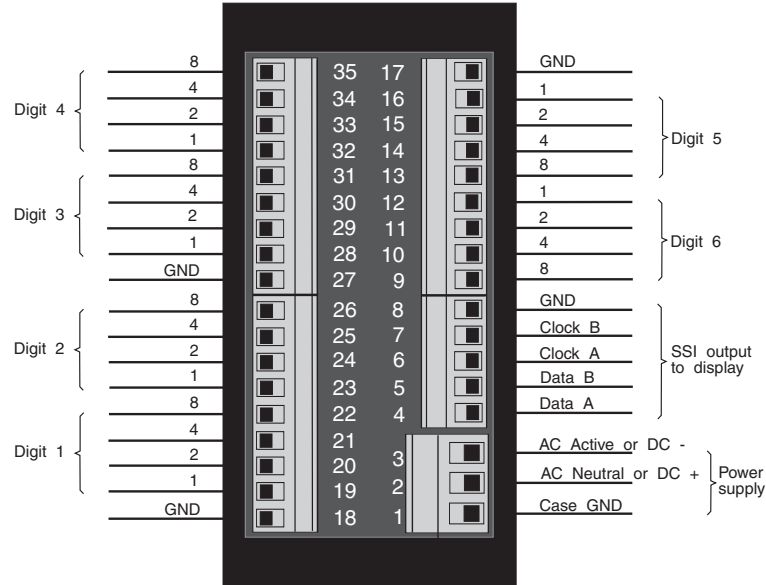

Input circuit *bc 24* parallel mode connection

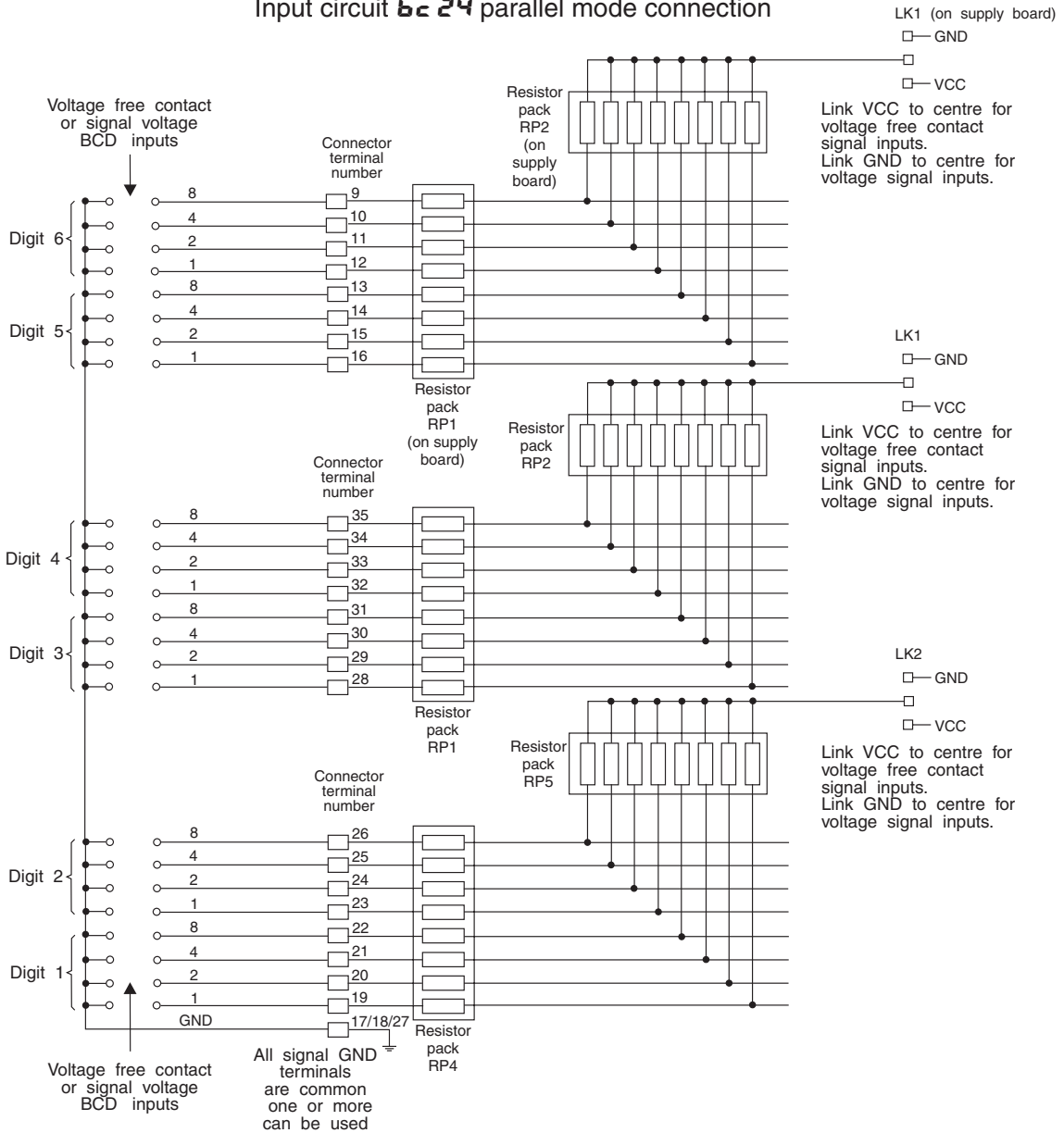

3.5 Model SS24 strobed input connections

Display unit main settings $SEt 1 NPt = bcd. 1 NPt = Str b. SEt OPEr = bc 8$

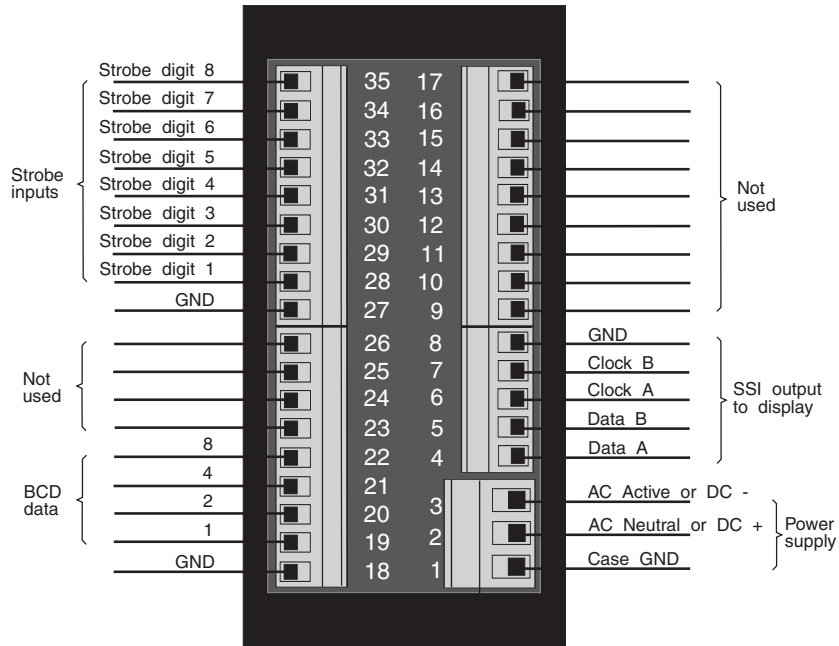

Input circuit $bc 24$ strobed connection

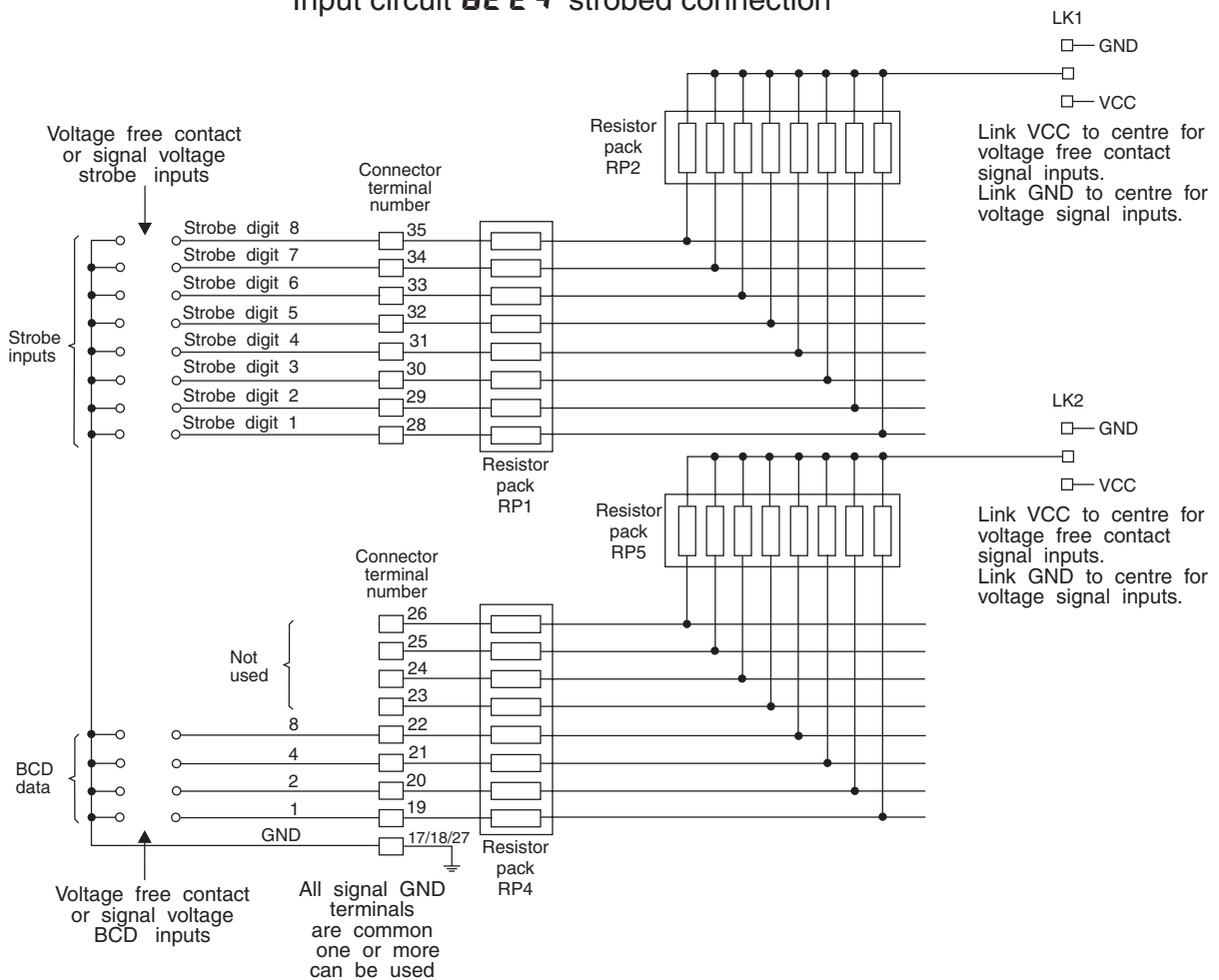

Strobe mode operation:

1. Set data value
2. Activate required strobe input when ready

3.6 Model SS24 addressed input connections

Display unit main settings $SEt 1 NPt = bcd, 1 NPt = Addr, SEt OPEr = bc 8$

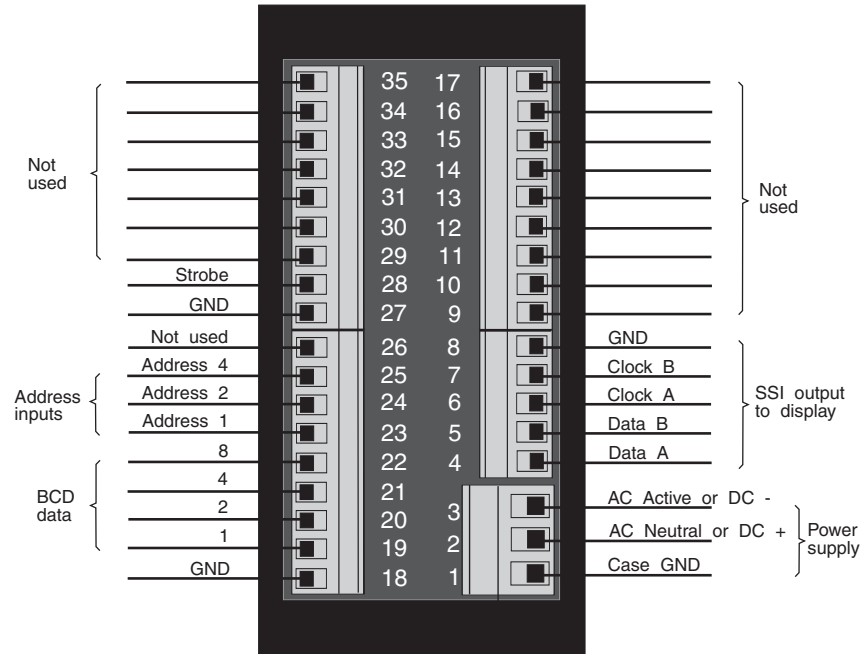

Input circuit $bc 24$ addressed mode connection

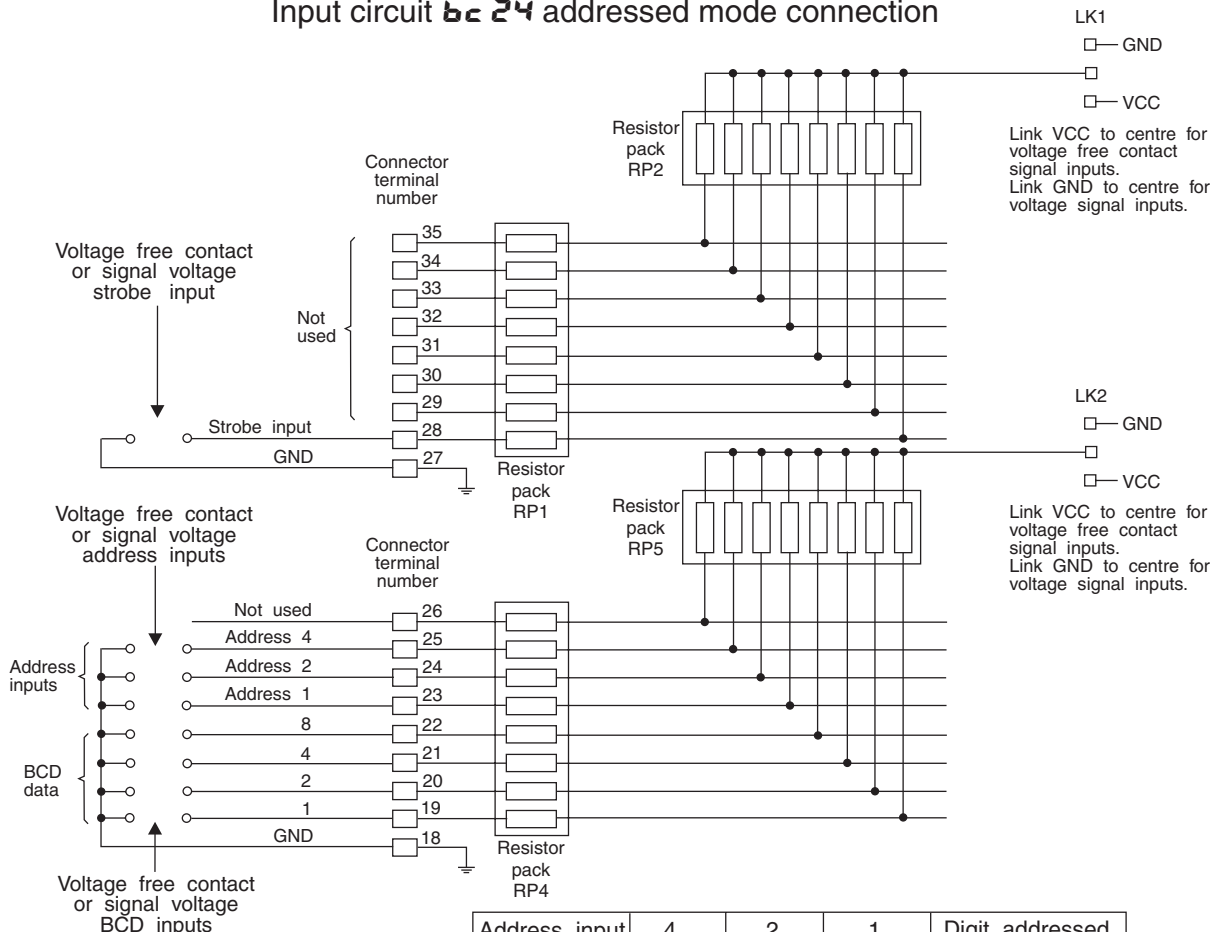

Addressed mode operation:

1. Set data value
2. Set address
3. Activate strobe input when ready

Address input	4	2	1	Digit addressed
Status	Inactive	Inactive	Inactive	1
	Inactive	Inactive	Active	2
	Inactive	Active	Inactive	3
	Inactive	Active	Active	4
	Active	Inactive	Inactive	5
	Active	Inactive	Active	6
	Active	Active	Inactive	7
	Active	Active	Active	8

3.7 Output connections

The output from this unit is designed to be connected to a model PM4-SSI, LD-SS or RM4-SSI display/controller. See the appropriate model manual for electrical input and setup details.

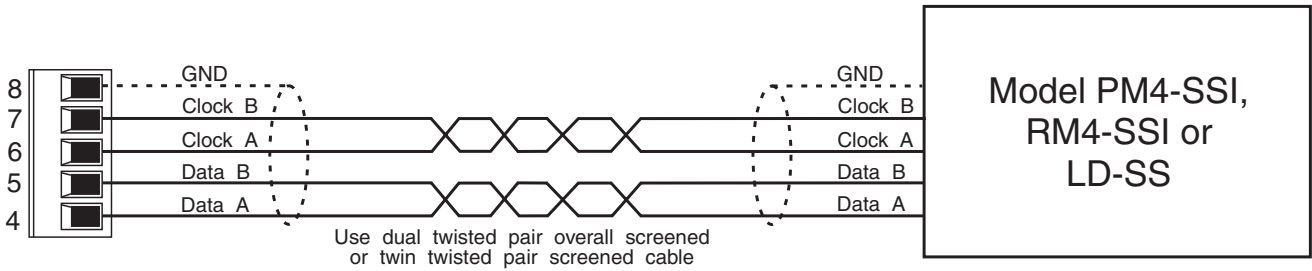

3.8 Power supplies

Power supplies are factory configured from the following choices: 240VAC, 110VAC, 24VAC, 12 to 48VDC isolated or 12 to 24VDC non isolated. Check supply type fitted before connecting. Current consumption with DC supplies is less than 30mA.

3.9 Link settings

Links LK1 (and LK2 for SS24 model) are used to select pull up to VCC at 5VDC or pull down to GND for the input lines. Place the link supplied between the centre connector and VCC if the input signals are voltage free contacts from a switch, relay etc. or select GND if voltage signals are used.

3.10 Resistor packs

Resistor packs RP1 is fitted for use as current limiting resistors on all the signal input lines. Note for SS24 models there is a second RP1 resistor pack and a resistor pack RP4 . The value of the resistor pack chosen depends on the level of the input voltage as shown in the table below.

Input type or voltage	Resistor networks RP1, RP1 & RP4
Voltage free contact	100Ω
5 volt input	100Ω
12 to 24 volt input	10KΩ
48 volt input	22KΩ

3.11 Timing for strobe and address operation.

As shown below the strobe line must become active no later than 10uS from the data and address lines becoming active. The strobe must be held active up to at least 10uS before the data and address lines become inactive. When the strobe is active the input is transparent i.e. if the data changes whilst the strobe is active then the change in the data input will be passed to the output. Data will be held whilst the strobe is inactive. The strobe must be active for at least 5uS. If more than one strobe is active then more than one digit will change. In addressed operation modes the strobe input is still needed before new data can be accepted. If necessary the strobe can be tied to a permanently active state.

