

**Panel meter model PM6-LP-4C  
and field mount model RT6-LP-4C  
Loop Powered Displays  
Operation and Instruction Manual**

---

*AMALGAMATED INSTRUMENT CO PTY LTD*

ACN: 001 589 439

*Unit 5, 28 Leighton Place Hornsby  
NSW 2077 Australia*

*Telephone: +61 2 9476 2244  
Facsimile: +61 2 9476 2902*

*e-mail: [sales@aicpl.com.au](mailto:sales@aicpl.com.au)  
Internet: [www.aicpl.com.au](http://www.aicpl.com.au)*

# Table of Contents

<b>1</b>	<b>Introduction</b>	<b>3</b>
<b>2</b>	<b>Mechanical Installation</b>	<b>4</b>
<b>3</b>	<b>Electrical installation</b>	<b>6</b>
<b>4</b>	<b>Function tables - summary of setup functions</b>	<b>9</b>
<b>5</b>	<b>Explanation of functions</b>	<b>10</b>
<b>6</b>	<b>Calibration</b>	<b>17</b>
<b>7</b>	<b>Specifications</b>	<b>20</b>
<b>8</b>	<b>Guarantee and service</b>	<b>21</b>

# 1 Introduction

## 1.1 General description

This manual contains information for the installation and operation of the panel mount model PM6-LP-4C and IP65 field mount model RT4-LP-4C monitors. These two wire loop powered displays will accept an input of 4 to 20 mA DC (or 10 to 50mA if selected). The instruments may be calibrated to display the input in engineering units. The instruments provide features such as display rounding, digital filtering (improves stability by reducing susceptibility to noisy signals) and visual over/under level warning. Unless otherwise specified at the time of order, your PM6 or RT6 has been factory set to a standard configuration.

Like all other PM6 and RT6 series instruments the configuration and calibration is easily changed by the user via push button functions. The instrument is totally powered by the measured current loop and requires no additional power supply. Since these displays require a 2.3 volt nominal loop voltage drop, they are especially suitable for current loops that would otherwise exceed their power supply capacity with too many devices connected.

The PM6 series of panel mount monitors are designed for high reliability in industrial applications. The RT6 series of field mount monitors provides the same features of the PM6-LP-4C loop powered displays in an IP65 enclosure. The high contrast LCD displays provide good visibility especially in areas with high ambient light levels.

PM6-LP-4C



RT6-LP-4C

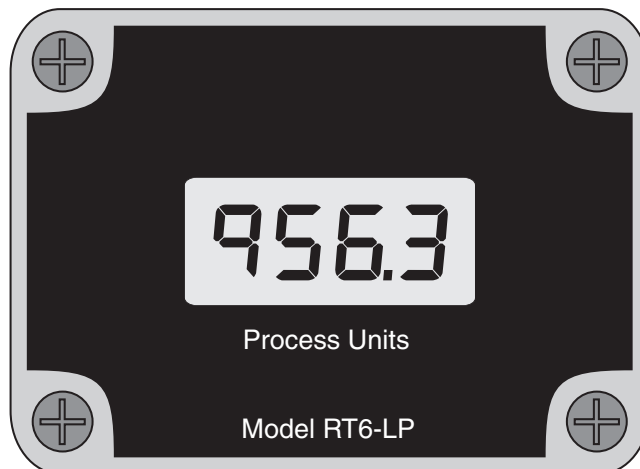

## 2 Mechanical Installation

Choose a mounting position as far away as possible from sources of electrical noise such as motors, generators, fluorescent lights, high voltage cables/bus bars etc.

### PM6 Mechanical details

An IP65 access cover which may be installed on the panel and surrounds is available as an option to be used when mounting the instrument in damp/dusty positions. A wall mount case is available, as an option, for situations in which panel mounting is either not available or not appropriate. An optional portable carry case is also available.

Prepare a panel cut out of 45mm x 92mm +1 mm / - 0 mm (see diagram below). Insert the instrument into the cut out from the front of the panel. From the rear of the instrument fit the two mounting brackets into the recess provided (see diagram below). Whilst holding the bracket in place, tighten the securing screws being careful not to over-tighten, as this may damage the instrument. Hint: use the elastic band provided to hold the mounting bracket in place whilst tightening securing screws.

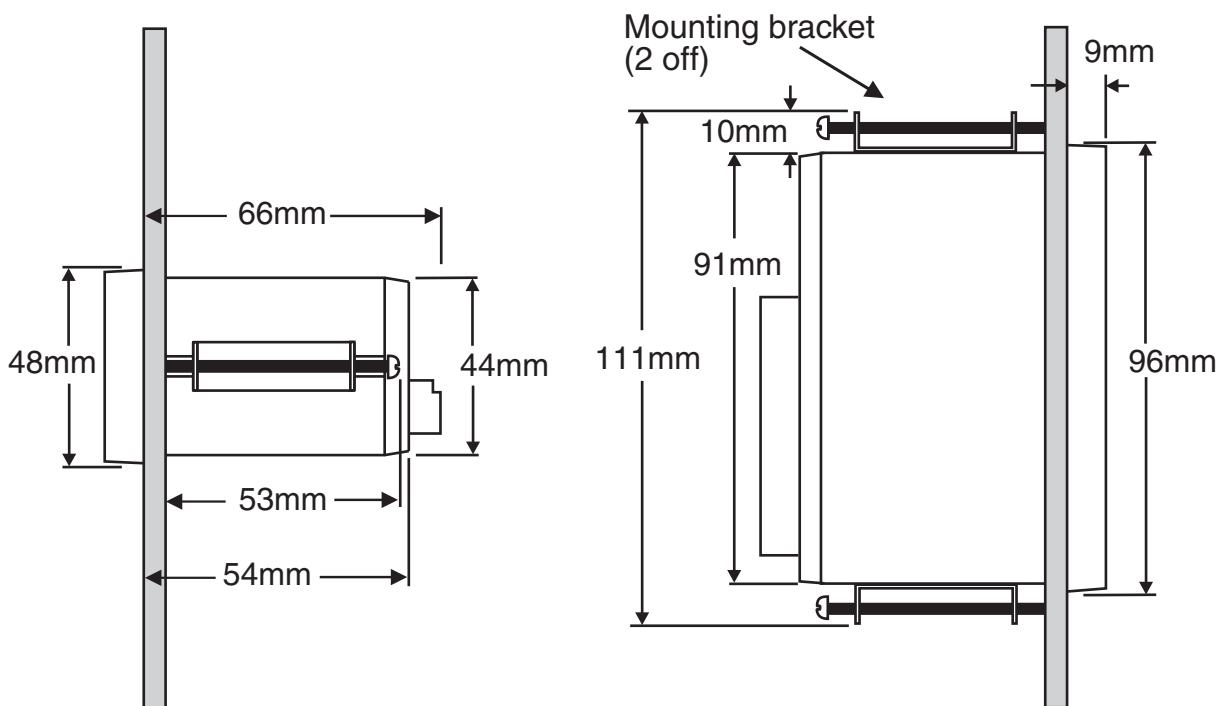
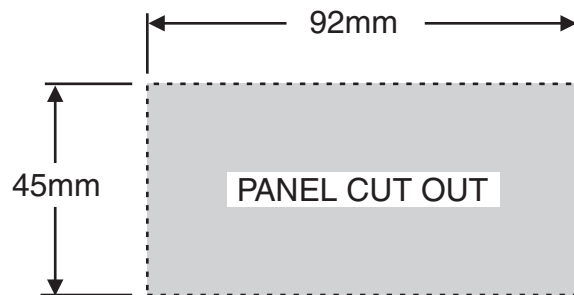

### RT6 Mechanical details

Mounting hole locations for surface mounting are provided with 90mm and 60mm centers. Remove the lid to gain access to the mounting holes. A PG9 cable gland is provided for cable entry, drill a 16mm dia. hole for this gland in a suitable position in the bottom section of the case. Remove top section of the case before drilling to protect the circuit boards. Note that there is a keyway on the top right hand corner of the lid (male key) and base (female key), ensure the keyway is in correct orientation before fixing the base to a surface. The lid will not fit correctly unless the keyways match.

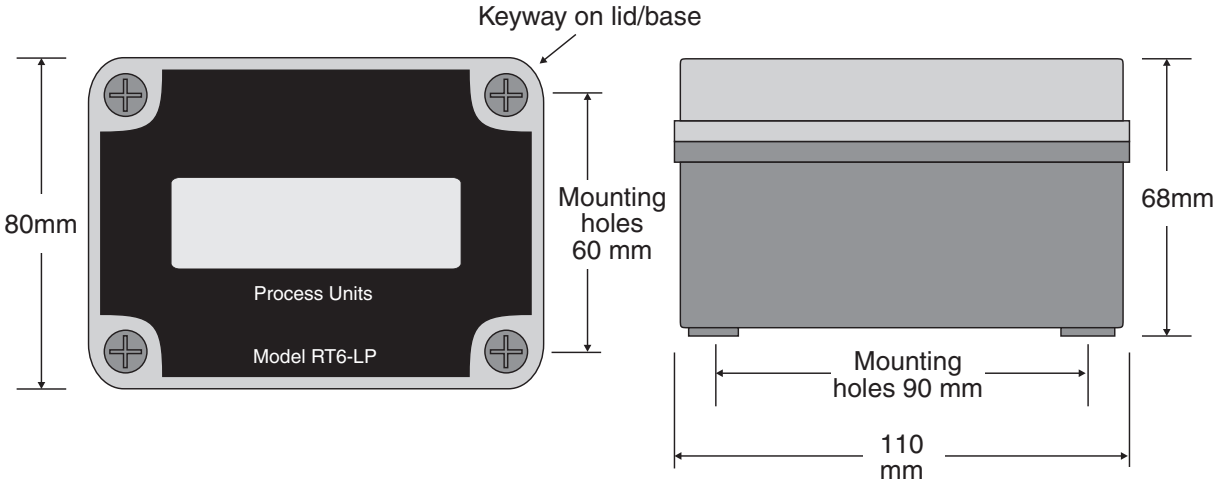

### 3 Electrical installation

#### 3.1 Electrical installation

The PM6 and RT6 loop powered displays are designed for continuous operation and no power switch is fitted.

The screw type terminal blocks allow for wires of up to 2.5mm<sup>2</sup> to be fitted, PM6 connectors are plug in type screw connectors. Connect the wires to the appropriate terminals as indicated below. Wiring to the remote inputs is required only if a remote input function e.g. peak hold is selected.

When loop power is applied the instrument will cycle through a display sequence indicating the software version and other status information, this indicates that the instrument is functioning. The use of screened cable is recommended for signal inputs.

#### 3.2 PM6 rear panel

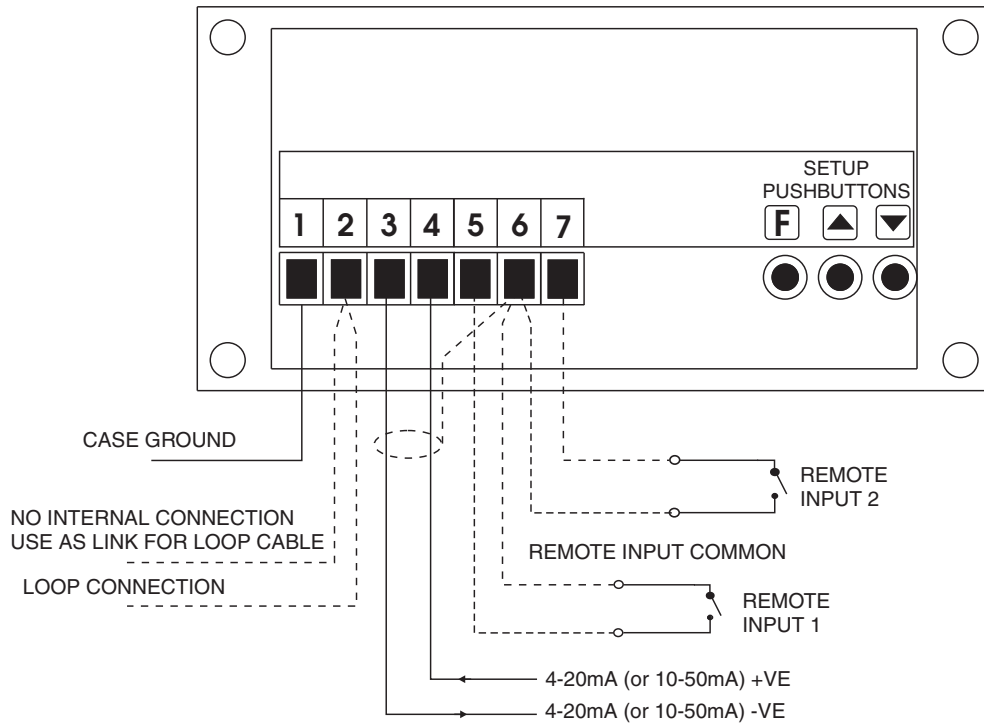

#### 3.3 PM6 data label (located on top of case)

 EMC Compliant	
1 CASE GROUND 2 LOOP CONNECTION 3 4-20mA INPUT -VE 4 4-20mA INPUT +VE 5 REMOTE INPUT 1 6 REMOTE INPUT COMMON	7 REMOTE INPUT 2
PM6-LP-4C	SERIAL No.

### 3.4 PM6 connection to a transmitter

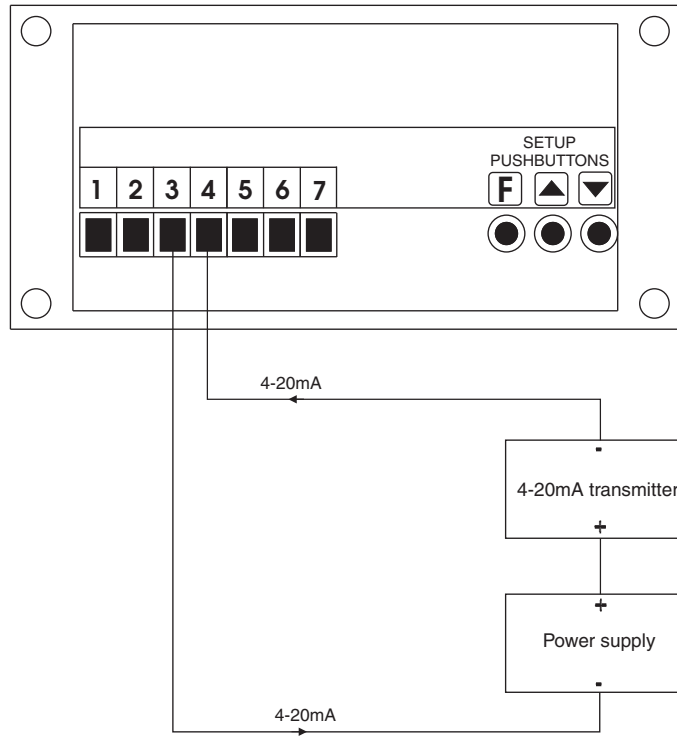

### 3.5 PM6 connection with two displays in one loop

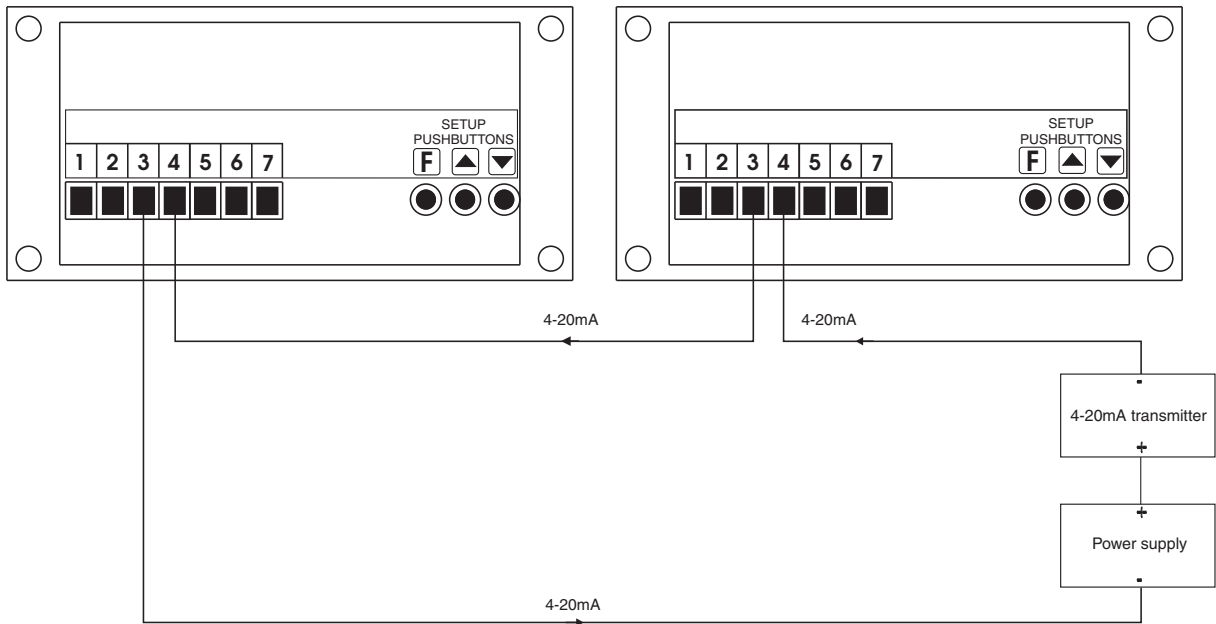

### 3.6 RT6 electrical connections

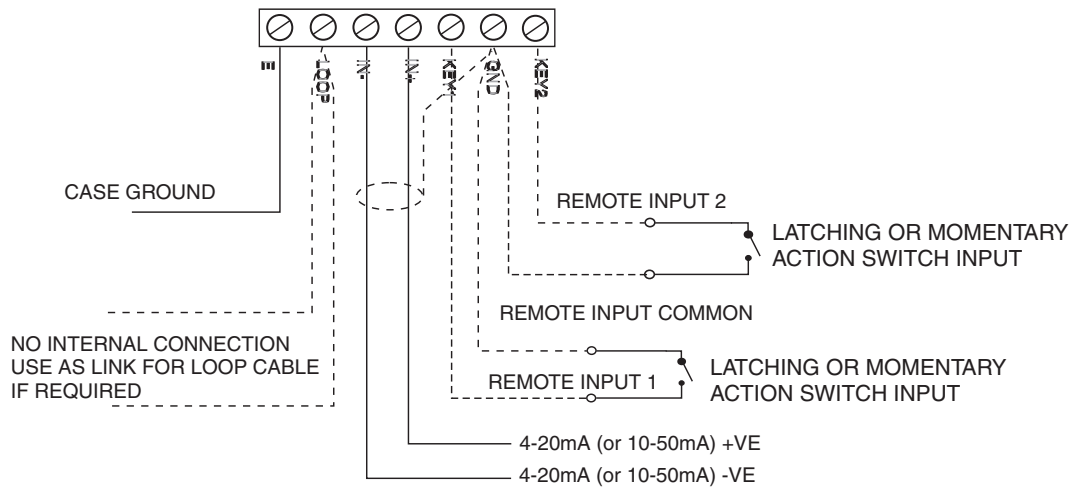

### 3.7 RT6 connection to a transmitter

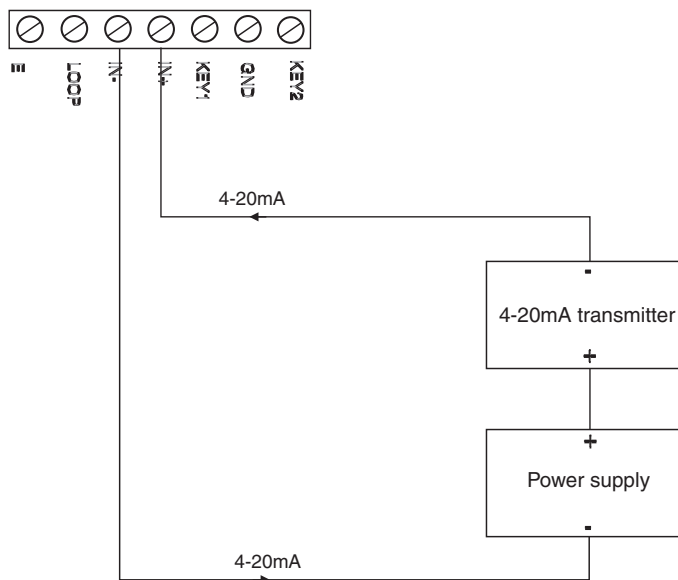

### 3.8 RT6 connection with two displays in one loop

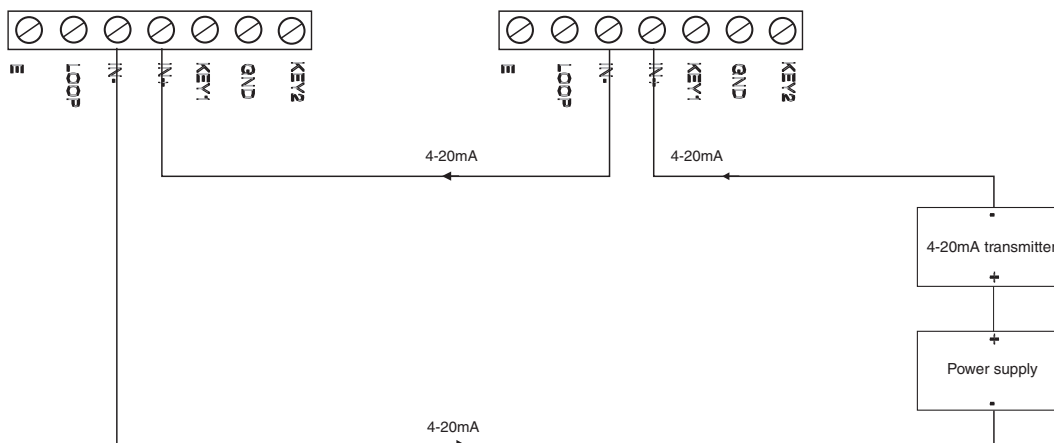

## 4 Function tables - summary of setup functions

Functions in this first table are available in **FUNC** or **CAL** mode

Display	Function	Range	Default	Your record	Ref/Page
<b>drnd</b>	Display rounding	<b>1</b> to <b>5000</b>	<b>1</b>		5.1 / 11
<b>FLtr</b>	Digital filter	<b>0</b> to <b>8</b>	<b>2</b>		5.3 / 11

Functions in this second table are available only in **CAL** mode or if **ACCS** is set to **ALL**

Display	Function	Range	Default	Your record	Ref/Page
<b>dCPt</b>	Decimal point	<b>0, 0.1</b> etc.	<b>0</b>		5.2 / 11
<b>CAL 1</b>	First live input calibration scaling point	Any display value	n/a		5.4 / 12
<b>CAL 2</b>	Second live input calibration scaling point	Any display value	n/a		5.5 / 12
<b>CAL OFSt</b>	Calibration offset	Any display value	n/a		5.6 / 12
<b>SCLE En4</b>	4mA input scale	Any display value	n/a		5.7 / 12
<b>SCLE En20</b>	20mA input scale	Any display value	n/a		5.8 / 12
<b>UCAL</b>	Uncalibrate	n/a	n/a		5.9 / 13
<b>F.I NP</b>	Remote input 1 function	<b>NONE, P.HLd, d.HLd, Hi, Lo</b>	<b>NONE</b>		5.10 / 13
<b>F.I N2</b>	Remote input two (external input) function	<b>NONE, P.HLd, d.HLd, Hi, Lo</b>	<b>NONE</b>		5.11 / 13
<b>Lo di SP</b>	Low overrange visual warning limit value	Any display value or <b>OFF</b>	<b>OFF</b>		5.12 / 14
<b>Hi 9H di SP</b>	High overrange visual warning limit value	Any display value or <b>OFF</b>	<b>OFF</b>		5.13 / 14
<b>di SP</b>	Display visual warning flashing mode	<b>FLASH</b> or <b>-or-</b>	<b>FLASH</b>		5.14 / 14
<b>ACCS</b>	Access mode	<b>OFF, NONE</b> or <b>ALL</b>	<b>OFF</b>		5.15 / 15
<b>Sqr t</b>	Square root mode	<b>on</b> or <b>OFF</b>	<b>OFF</b>		5.16 / 15
<b>input</b>	Input range 4–20mA or 10–50mA	<b>4-20</b> or <b>10.50</b>	<b>4-20</b>		5.17 / 15

# 5 Explanation of functions

Setup and calibration functions are configured through a push button sequence. The three push buttons located at the rear of the PM6 are used to alter settings. Two basic access modes are available:

**FUNC** mode (simple push button sequence) allows access to commonly set up functions such as decimal point.

**CAL** mode (power up sequence plus push button sequence) allows access to all functions including calibration parameters.

Once **CAL** or **FUNC** mode has been entered you can step through the functions, by pressing and releasing the **F** push button, until the required function is reached. Changes to functions are made by pressing the or push button (in some cases both simultaneously) when the required function is reached. See the flow chart example on the following page.

Note: if the **ACCESS** function is set to **ALL** then access to all functions can be made via **FUNC** mode, this allows access to all functions without the need to power down.

## Entering **CAL** Mode



1. Remove power from the instrument. Hold in the **F** button and reapply power. The display will briefly indicate **CAL** as part of the "wake up messages" when the **CAL** message is seen you can release the button. Move to step 2 below.



2. When the "wake up" messages have finished and the display has settled down to its normal reading press, then release the **F** button. Move to step 3 below.

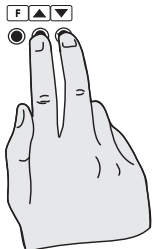

3. Within 2 seconds of releasing the **F** button press, then release the **▲** and **▼** buttons together. The display will now indicate **FUNC** followed by the first function.

Note: If step 1 above has been completed then the instrument will remain in this **CAL** mode state until power is removed. i.e. there is no need to repeat step 1 when accessing function unless power has been removed.

## Entering **FUNC** Mode

No special power up procedure is required to enter **FUNC** mode.



1. When the "wake up" messages have finished and the display has settled down to its normal reading press, then release the **F** button.

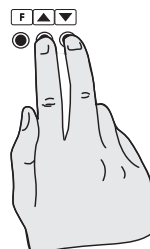

2. Within 2 seconds of releasing the **F** button press, then release the **▲** and **▼** buttons together. The display will now indicate **FUNC** followed by the first function.

Example: Entering **CAL** mode to change **Sqrt** function from **OFF** to **on**

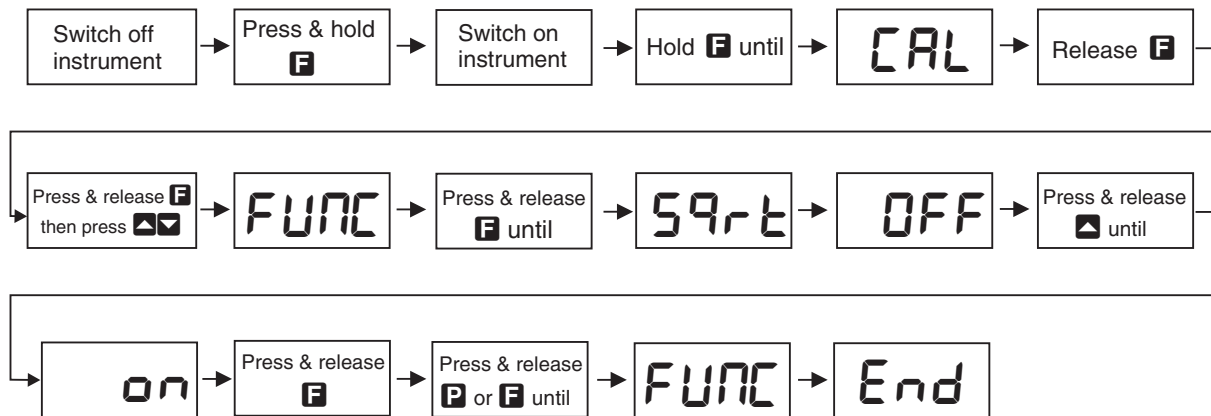

## Explanation of Functions

### 5.1 Display rounding

Display: **drnd**  
 Range: **1** to **5000**  
 Default Value: **1**

Displays and sets the display rounding value. This value may be set to 1 - 5000 displayed units. Display rounding is useful for reducing the instrument resolution without loss of accuracy in applications where it is undesirable to display to a fine tolerance. To set the display rounding value go to the **drnd** function and use the **▲** or **▼** push buttons to set the required value then press **F** to accept this selection.

**Example:** If set to **10** the display values will change in multiples of 10 only i.e. display moves from **10** to **20** to **30** etc.

### 5.2 Decimal point

Display: **dCPE**  
 Range: **0**, **0.1** etc.  
 Default Value: **0**

Displays and sets the decimal point. By pressing the **▲** or **▼** pushbutton at the **dCPE** function the decimal point position may be set. The display will indicate as follows: **0** (no decimal point), **0.1** (1 decimal place), **0.02** (2 decimal places) or **0.003** (3 decimal places). Note if the decimal point is altered the display will need to be recalibrated.

### 5.3 Digital filter

Display: **FLtr**  
 Range: **0** to **8**  
 Default Value: **2**

Displays and sets the digital filter value. Digital filtering uses a weighted average method of determining the display value and is used for reducing display value variation due to short term interference. The digital filter range is selectable from **0** to **8**, where **0** = none and **8** = most filtering. Use **▲** or **▼** at the **FLtr** function to alter the filter level if required. Note that the higher the filter setting the longer the display may take to reach its final value when the input is

changed, similarly the relay operation and any output options will be slowed down when the filter setting is increased. To set the digital filter value go to the **FILTER** function and use the **▲** or **▼** push buttons to set the required value then press **F** to accept this selection.

## 5.4 First calibration scaling point

**Display:** **CAL 1**  
**Range:** Any display value  
**Default Value:** n/a

First scaling point for 2 point calibration scaling - See “Calibration” chapter, section 6.1.

## 5.5 Second calibration scaling point

**Display:** **CAL 2**  
**Range:** Any display value  
**Default Value:** n/a

Second scaling point for 2 point calibration scaling - See “Calibration” chapter, section 6.1.

## 5.6 Calibration offset

**Display:** **CAL OFFSE**  
**Range:** Any display value  
**Default Value:** n/a

Calibration offset - See section 6.2.

## 5.7 4mA input scale

**Display:** **SCALE E04**  
**Range:** Any display value  
**Default Value:** n/a

4mA input scale value, use only as an alternative to **CAL 1** and **CAL 2** calibration - See “Calibration” chapter, section 6. This function will be displayed as **SCALE E010** if set for 10–50mA input.



## 5.8 20mA input scale

**Display:** **SCALE E020**  
**Range:** Any display value  
**Default Value:** n/a

20mA input scale value, use only as an alternative to **CAL 1** and **CAL 2** calibration - See “Calibration” chapter, section 6. This function will be displayed as **SCALE E050** if set for 10–50mA input.

## 5.9 Uncalibrate

Display: **UCAL**  
Range: n/a  
Default Value: n/a

Uncalibrate, resets calibration - required only when a calibration problem occurs and it is necessary to clear the calibration memory. At the **UCAL** function press the  and  buttons simultaneously. The message **CAL CLR** should be seen to indicate that the calibration memory has been cleared.

## 5.10 Remote input 1 function

Display: **F.I NP**  
Range: **NONE, P.HLD, d.HLD, H<sub>i</sub>, Lo**  
Default Value: **NONE**

Remote input function - terminals 8 and 9 at the rear of the instrument are the remote input terminals. When these terminals are short circuited via a switch, relay, keyswitch etc. the instrument will perform the selected remote input function. A message will flash to indicate which function has been selected when the remote input pins are short circuited. The remote input functions are as follows:

- **NONE** - no remote function required i.e. activating the remote input has no effect.
- **P.HLD** - display peak hold. The display will show the peak value (highest positive value) only whilst the remote input terminals are short circuited i.e. the display value can rise but not fall whilst the input terminals are short circuited. The message **P.HLD** will appear briefly every 8 seconds whilst the input terminals are short circuited to indicate that the peak hold function is active.
- **d.HLD** - display hold. The display value will be held whilst the remote input terminals are short circuited. The message **d.HLD** will appear briefly every 8 seconds whilst the input terminals are short circuited to indicate that the display hold function is active.
- **H<sub>i</sub>** - peak memory. The peak value stored in memory will be displayed if the remote input terminals are short circuited, if the short circuit is momentary then the display will indicate the peak memory value then return to normal measurement after 30 seconds. To reset the memory hold the remote input closed for 2 to 3 seconds or remove power from the instrument. The message **P H<sub>i</sub>** will appear briefly every 8 seconds whilst the input terminals are short circuited to indicate that the peak memory function is active.
- **Lo** - valley memory. The minimum value stored in memory will be displayed. The message **P Lo** will appear briefly every 8 seconds whilst the input terminals are short circuited to indicate that the peak memory function is active. Otherwise operates in the same manner as the **H<sub>i</sub>** function described above.

## 5.11 Remote input 2 function

Display: **F.I N2**  
Range: **NONE, P.HLD, d.HLD, H<sub>i</sub>, Lo**  
Default Value: **NONE**

Remote input two functions, operates in the same manner as the first remote input but uses

terminals 9 and 10. Refer to **F.I NP**, section 5.10 for description. Note: unless set to **NONE** it is essential that **F.I NP** and **F.I N2** are not set for the same function.

## 5.12 Low overrange visual warning limit value

**Display:** **Lo di SP**  
**Range:** Any display value or **OFF**  
**Default Value:** **OFF**

Low overrange limit value - the display can be set to show an overrange message if the display value falls below the **Lo di SP** setting. For example if **Lo di SP** is set to **50** then once the display reading falls below **50** the message **-or-** will flash on and off or the display value will flash on and off instead of the normal display units (see **di SP** function 5.14). This message can be used to alert operators to the presence of an input which is below the low limit. If this function is not required it should be set to **OFF** by pressing the **▲** and **▼** buttons simultaneously at this function.

## 5.13 High overrange visual warning limit value

**Display:** **Hi 9H di SP**  
**Range:** Any display value or **OFF**  
**Default Value:** **OFF**

High overrange limit value - the display can be set to show an overrange message if the display value rises above the **Hi 9H di SP** setting. For example if **Hi 9H di SP** is set to **1000** then once the display reading rises above **1000** the message **-or-** will flash on and off or the display value will flash on and off instead of the normal display units (see **di SP** function 5.14). This message can be used to alert operators to the presence of an input which is above the high limit. If this function is not required it should be set to **OFF** by pressing the **▲** and **▼** buttons simultaneously at this function.

## 5.14 Display visual warning flashing mode

**Display:** **di SP**  
**Range:** **FLSH** or **-or-**  
**Default Value:** **FLSH**

Display overrange warning flashing mode - this function is used in conjunction with the **Lo di SP** and **Hi 9H di SP** functions. The **di SP** function can be set to **FLSH** or **-or-**. If the display warning value set at the **Lo di SP** or **Hi 9H di SP** function is exceeded and the **di SP** function is set to **FLSH** then the display value will flash on and off every second as a visual warning. If the display warning value set at the **Lo di SP** or **Hi 9H di SP** function is exceeded and the **di SP** function is set to **-or-** then the **-or-** message will flash on and off once a second as a visual warning. The warning flashes will cease and the normal display value will be seen when the value displayed is higher than the low limit and lower than the high limit.

## 5.15 Access mode

Display: **ACCS**  
Range: **OFF**, **NONE** or **ALL**  
Default Value: **OFF**

Access mode - the access mode function **ACCS** has three possible settings namely **OFF**, **NONE** and **ALL**. If set to **OFF** the function has no effect. If set to **NONE** there will be no access to any functions via **FUNC** mode, entry via **CAL** mode must be made to gain access to functions. If set to **ALL** then access to all functions, including calibration functions, can be gained via **FUNC** mode i.e. when set to **ALL** there is no need to power down to gain access to all functions.

## 5.16 Square root mode

Display: **Sqr t**  
Range: **on** or **OFF**  
Default Value: **OFF**

Square root - selects the square root scaling to **on** or **OFF**. When set to **on** a square root function is applied to the input. When set to **OFF** the calibration is a linear function. When the square root facility is used the scaled displayed value follows the square root of the percentage of the full scale input value. The upper and lower input limits are set as normal as are the values to be displayed at these limits.

Notes: It is essential that the display is rescaled, using **CAL 1** and **CAL 2** or **SCALE EN4** and **SCALE EN20**, whenever the square root function is turned on or off. The **CAL OFSt** function cannot be used when the **Sqr t** function is set to **on**. The square root operation will not work if the rate is scaled to show negative values.

### Example:

For a 4–20mA input if you wish to display 0 at 4mA and 1000 at 20mA the square root function will calculate as follows:

At 20mA (100%) the display will be **1000** i.e.  $\sqrt{1} \times 1000$ .

At 16mA (75%) the display will be **866** i.e.  $\sqrt{0.75} \times 1000$ .

At 12mA (50%) the display will be **707** i.e.  $\sqrt{0.5} \times 1000$  and so on.

## 5.17 Input range

Display: **, nPt**  
Range: **4-20** or **10.50**  
Default Value: **4-20**

Selects the input range to be used as 4–20mA or 10–50mA.

## 5.18 Returning to normal measure mode

When the calibration has been completed it is advisable to return the instrument to the normal mode (where calibration functions are less likely to be tampered with). To return to normal mode, turn off power to the instrument, wait a few seconds and then restore power.

## 5.19 Error messages

**SPAN Err** - calibration span error. Live inputs used at **CAL 1** and **CAL 2** too close in value. Recalibrate using inputs further apart in value. If you are certain that the inputs are far enough apart but still see the **SPAN Err** message then ignore the message and continue with the two point calibration. At the end of the calibration check to see if the display calibration is correct and if not recalibrate using the same inputs.

**Unstable display** - if the display is not stable the usual cause is either that the input signal is unstable or that the calibration scaling was incorrectly attempted. If the calibration scaling was unsuccessful then uncalibrating the display at the **UCAL** function should return the display to stable readings but the previous calibration scaling values will be lost. If the display is still not stable after uncalibrating then check the input for stability and noise.

**Display shows “- - - -”** - this message indicates that the input signal is higher than the range selected e.g. higher than 20mA (or 50mA if set for 10–50mA).

**Display shows “-or-”** - this message indicates either that the number is too big to display e.g. above **9999** or that the **di SP** function has been set to **-or-** and either the **Lo di SP** or **Hi 9H di SP** limits have been exceeded.

**Display value flashes on and off** - this indicates that **di SP** function has been set to **FLSH** and either the **Lo di SP** or **Hi 9H di SP** limits have been exceeded.

**Display shows NO ACC** - this indicates that the **ACCS** function has been set to **NONE** blocking entry to **FUNC** mode. Enter functions via **CAL** mode to gain entry to functions and if required change the **ACCS** function setting.

## 6 Calibration

The instrument can be calibrated via a two point live input calibration method using functions **CAL 1** and **CAL 2**. An alternative method allows display scaling without live inputs using the **SCLE En4** and **SCLE En20** or **SCLE En10** and **SCLE En50** functions. Each of these methods and other calibration scaling function are described in this chapter.

In order to gain access to the calibration functions you must be in **CAL** mode or have the **ACCESS** function set to **ALL**, refer to Chapter 5, page 10 which shows the method of entering **CAL** mode.

### 6.1 Live signal input calibration

**CAL 1** and **CAL 2** - The functions **CAL 1** and **CAL 2** are used together to scale the instruments display, values for both **CAL 1** and **CAL 2** must be set when using this scaling method. The **CAL 1** function sets the first calibration point for live input calibration. When using this method different signal level inputs must be present at the input terminals for **CAL 1** and **CAL 2**. Note: **CAL 1** and **CAL 2** can be set independently.

The procedure for entering the first scaling point **CAL 1** is as follows:

- Ensure that an input signal is present at the input terminals, this will usually be at the low end of the signal range e.g. 4mA.
- At the **CAL 1** function press **▲** and **▼** simultaneously then release them. The display will show the live input value. Do not be concerned at this stage if the live input display value is not what is required. It is important that the live input value seen is a steady value, if not then the input needs to be investigated before proceeding with the scaling.
- Press then release the **F** button. The display will indicate **SCL 1** followed by a value. Use the **▲** or **▼** button to change this value to the required display value at this input. e.g. if 4mA was input and the required display at 4mA was **0** then ensure **0** is entered at **SCL 1**. Press the **F** button to accept changes. If the scaling has been accepted the **CAL End** message should be seen.

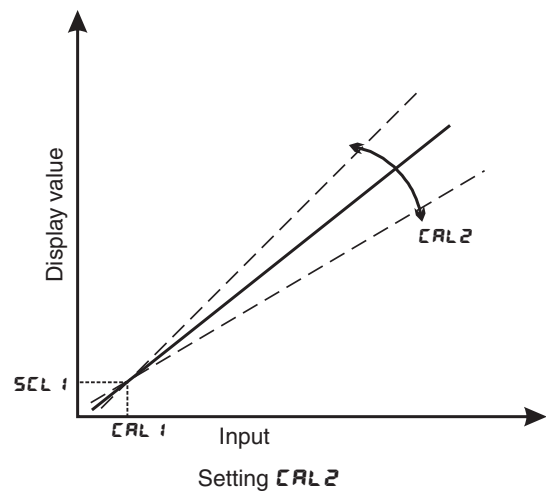
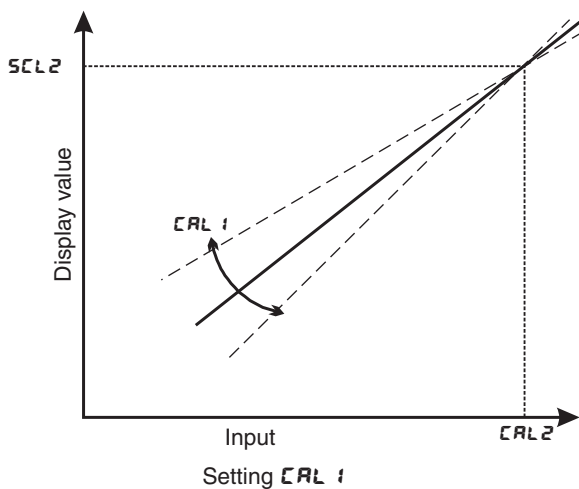

The procedure for entering the second scaling point **CAL 2** is as follows:

- a. Ensure that an input signal is present at the input terminals, this will usually be at the high end of the signal range i.e. close to 20mA . The change in input signal from the **CAL 1** input must be at least 2mA .
- b. At the **CAL 2** function press **▲** and **▼** simultaneously then release them. The display will show the live input value. Do not be concerned at this stage if the live input display value is not what is required. It is important that the live input value seen is a steady value, if not then the input needs to be investigated before proceeding with the scaling.
- c. Press then release the **F** button. The display will indicate **SCL 2** followed by a value. Use the **▲** or **▼** button to change this value to the required display value at this input. e.g. if 20mA was input and the required display at 20mA was **500** then ensure **500** is entered at **SCL 2**. Press the **F** button to accept changes. If the scaling has been accepted the **CAL End** message should be seen.

Example - Flow chart showing scaling using two live inputs

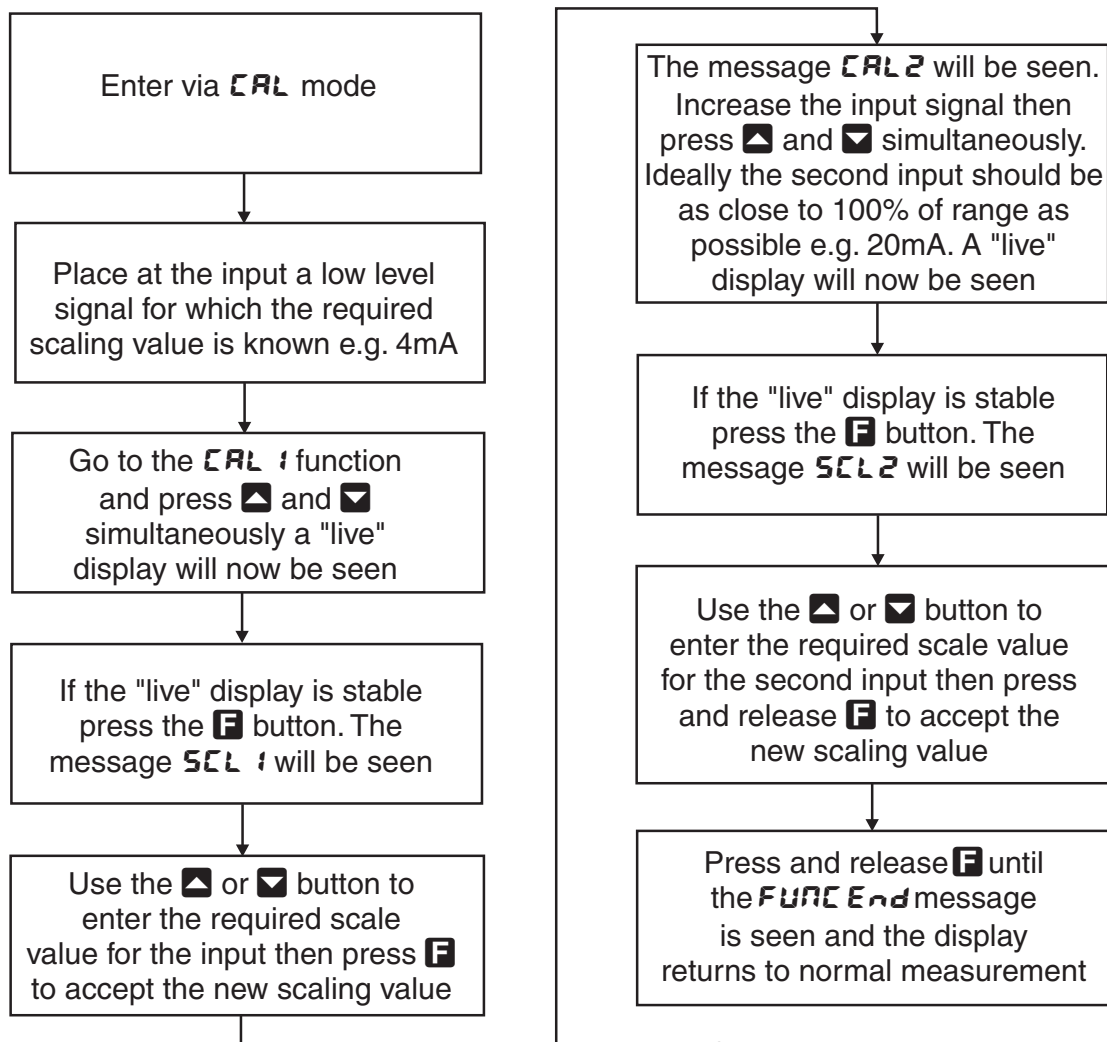

Note: If the "live" display at any scaling point is not stable then check the input signal for stability.

## 6.2 Offset calibration

**CAL OFFSE** - Calibration offset - the calibration offset is a single point adjustment which can be used to alter the calibration scaling values across the entire measuring range without affecting the calibration slope. This method can be used instead of performing a two point calibration when a constant measurement error is found to exist across the entire range. To perform a calibration offset press the **▲** and **▼** buttons simultaneously at the **CAL OFFSE** function. A “live” reading from the input will be seen, make a note of this reading. Press the **F** button, the message **SCALE** will now be seen followed by the last scale value in memory. Use the **▲** or **▼** button to adjust the scale value to the required display value for that input. For example if the “live” input reading was **50** and the required display value for this input was **70** then adjust the **SCALE** value to **70**. Press the **F** button to accept changes or the **P** button to abort the scaling. If the scaling has been accepted the message **OFFSE End** should be seen.

## 6.3 Alternative 4–20mA or 10–50mA scaling

This scaling method which uses functions **SCALE En4** and **SCALE En20** allows the display scale values for 4mA and 20mA to be directly entered without live input. When a sensor is subsequently connected a check for zero offset in the sensor should be made by viewing the display value at a point where the sensor output should be at 4mA output. A remote input zero or calibration offset can be used to adjust for any zero offset in the sensor, see **ZERO** and **CAL OFFSE** functions. If the slope of the sensor output is not correct then **CAL 1** and **CAL 2** methods will have to be used.

**SCALE En4** - 4mA input scaling without a live input - The instrument can be scaled for a 4–20mA input without a live input i.e. this is an alternative method to the **CAL 1** and **CAL 2** method of scaling. To perform the first point (**En4**) scaling simply press the **▲** and **▼** buttons simultaneously when the **SCALE En4** function is displayed. The display will now indicate a value. Use the **▲** or **▼** button to change this value to the display value required for a 4mA input. Press the **F** button to accept changes or the **P** button to abort the scaling. If the scaling has been accepted the **CAL End** message should be seen. Note: for 10–50mA inputs the messages will be **SCALE En 10** and **SCALE En50**.

**SCALE En20** - 20mA input scaling without a live input - this calibration method can be used with 4–20mA inputs only. To perform the second point (**En20**) scaling simply press the **▲** and **▼** buttons simultaneously when the **SCALE En20** function has been reached. The display will now indicate a value. Use the **▲** or **▼** button to change this value to the display value required for a 20mA input. Press the **F** button to accept changes or the **P** button to abort the scaling. If the scaling has been accepted the **CAL End** message should be seen. Note: for 10–50mA inputs the messages will be **SCALE En 10** and **SCALE En50**.

## 6.4 Uncalibration

**UCAL** - Uncalibrate - used to set the instrument back to the factory calibration values. This function should only be used when calibration problems exist and it is necessary to clear the calibration memory. To clear the calibration memory press the **▲** and **▼** buttons simultaneously at the **UCAL** function. The message **CAL CLR** will be seen to indicate that the memory has cleared.

## 7 Specifications

### 7.1 Technical specifications for PM6-LP-4C and RT6-LP-4C

Input type:	4 to 20mA or 10 to 50mA selectable
Loop voltage drop:	2 Volts at 4mA, 2.3 Volts at 20mA nominal
Current range:	Measurable from 3.5 to 22mA or 9 to 55mA
Input protection:	150mA in either direction
ADC resolution:	15 bit
Decimal points:	Up to 3 decimal point places selectable
Accuracy:	0.025% of full scale when calibrated $\pm 50\text{ppm}/^{\circ}\text{C}$ $\pm 1$ display digit
Sample Rate:	2.5 samples per second
Display update:	2.5 times per second
Ambient temperature:	-10 to 50° C
Humidity:	5 to 95% non condensing
Display:	LCD 4 digit 12.7mm

### 7.2 Physical Characteristics

#### PM6

Bezel Size:	DIN 48mm x 96mm x 9mm
Case Size:	44mm x 91mm x 66mm behind face of panel
Panel Cut Out:	45mm x 92mm +1mm/-0mm
Connections:	Plug in screw terminals (max. 2.5mm <sup>2</sup> wire)
Weight:	180 gms

#### RT6

Case Size:	110mm (w) x 80mm (h) x 68mm (d)
Connections:	Screw terminals (max. 2.5mm <sup>2</sup> wire)
Weight:	250 gms
IP rating:	IP65
Mounting holes:	Hole centres 90 and 60mm

## 8 Guarantee and service

The product supplied with this manual is guaranteed against faulty workmanship for a period of 2 years from the date of dispatch.

Our obligation assumed under this guarantee is limited to the replacement of parts which, by our examination, are proved to be defective and have not been misused, carelessly handled, defaced or damaged due to incorrect installation. This guarantee is VOID where the unit has been opened, tampered with or if repairs have been made or attempted by anyone except an au authorised representative of the manufacturing company.

Products for attention under guarantee (unless otherwise agreed) must be returned to the manufacturer freight paid and, if accepted for free repair, will be returned to the customers address in Australia free of charge.

When returning the product for service or repair a full description of the fault and the mode of operation used when the product failed must be given. In any event the manufacturer has no other obligation or liability beyond replacement or repair of this product.

Modifications may be made to any existing or future models of the unit as it may deem necessary without incurring any obligation to incorporate such modifications in units previously sold or to which this guarantee may relate.

This document is the property of the instrument manufacturer and may not be reproduced in whole or part without the written consent of the manufacturer.

This product is designed and manufactured in Australia.