

**PM6-IV**  
DC Current/DC Voltage  
Process Monitor  
Operation and Instruction Manual



---

## Table of Contents

---

<b>Introduction</b> . . . . .	<b>3</b>
<b>Mechanical installation</b> . . . . .	<b>4</b>
<b>Electrical installation</b> . . . . .	<b>5</b>
<b>Switching on the instrument</b> . . . . .	<b>7</b>
<b>Explanation of functions</b> . . . . .	<b>8</b>
<b>Setting up the PM6-IV</b> . . . . .	<b>10</b>
Setting the display rounding (dr nd) . . . . .	10
Setting the decimal point (dCPt) . . . . .	11
Setting the digital filter (FLt r) . . . . .	11
Setting up the display brightness (br gt) . . . . .	11
Setting up the input function (I NPt) . . . . .	11
Scale (SCLE) function . . . . .	12
Uncalibrating (UCAL) . . . . .	12
Select (SLCt) function . . . . .	12
Square root mode (SqRt) . . . . .	12
<b>Setup Examples</b> . . . . .	<b>13</b>
Setting the display rounding . . . . .	13
Setting the decimal point . . . . .	13
Setting the digital filter . . . . .	14
Setting the display brightness . . . . .	14
Setting the input range . . . . .	14
Setting the Scale (SCLE) . . . . .	15
Setting the UCAL (UCAL) . . . . .	15
Setting the select (SLCt) function . . . . .	16
<b>Setting the square root extractor</b> . . . . .	<b>16</b>
Changing multiple settings . . . . .	17
<b>Setting up the USER functions</b> . . . . .	<b>18</b>
Setting up the user function (USER) . . . . .	18
Example of setting the user function . . . . .	19
<b>Setting Up The Lineariser</b> . . . . .	<b>21</b>
Purpose of the lineariser (t bLE) mode . . . . .	21
Initial input scaling . . . . .	21
Using the lineariser . . . . .	21
Using the Pct 1 & 2 functions . . . . .	23
Entering values into the lineariser . . . . .	24
<b>Trouble Shooting</b> . . . . .	<b>25</b>
<b>Specifications</b> . . . . .	<b>26</b>
<b>Guarantee and Service</b> . . . . .	<b>27</b>

---

## 2 Introduction

---

This manual contains information on the installation and operation of the PM6-IV monitor. The PM6-IV accepts inputs in the ranges 0 to 2mA, 0 to 20mA, 4 to 20mA,  $\pm 100\text{mV}$ ,  $\pm 1$  Volt,  $\pm 10$  Volts,  $\pm 100$  Volts or user set input limits anywhere within the above ranges. The displayed output may be scaled to read in any engineering units. A square root extractor and 16 point lineariser is included, these can be selected and configured as required.

Unless otherwise specified at the time of order your PM6-IV has been factory set to a standard configuration. This configuration can be easily changed by the user. All changes to configuration are made via three push buttons located at the rear of the unit.

The PM6 series instruments are designed for high reliability in industrial applications. The LED display can be set for desired brightness level to suit most locations and light levels. The PM6 range of instruments are monitor only devices, other ranges of instruments are available to suit a wide range of instrumentation needs.



### 3 Mechanical installation

The dimensions of the PM6 are shown in the diagrams below. The panel cut out required to mount the PM6 is 45mm x 92mm as shown below. The tolerances on this cut out are +1mm/-0mm. Insert the panel meter from the front of the panel. From the rear of the instrument place the two mounting brackets into the side recesses. Whilst holding the brackets (the elastic bands provided may prove useful for this) tighten the securing screws. Be careful not to over tighten the screws as this could cause damage to the instrument casing.

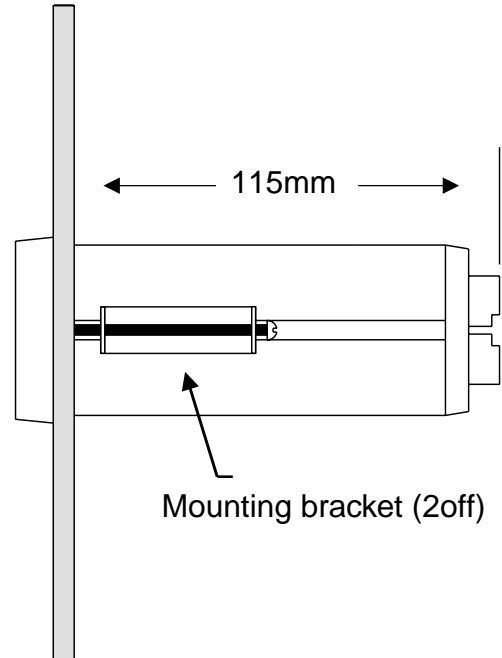
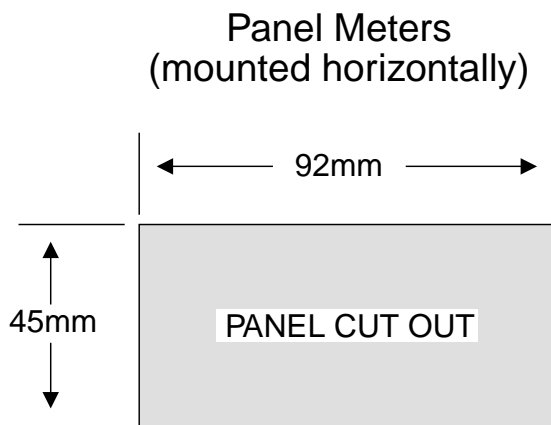
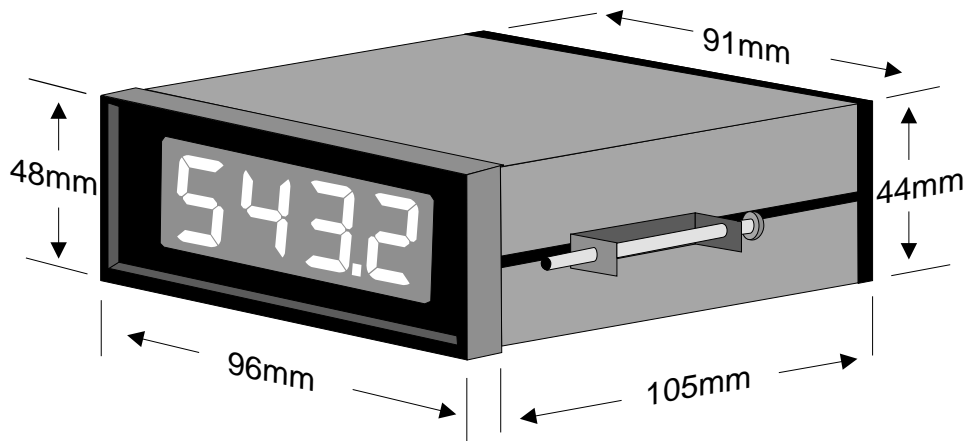

# 4 Electrical installation

The diagrams below show the electrical connection points for the PM6-IV. As the instrument is designed for continuous use no power switch is fitted. It is recommended that an external switch and fuse be provided to allow the unit to be removed for servicing.

The rear terminal blocks are of the plug in type for ease of connection. Wires of up to 2.5mm<sup>2</sup> may be fitted. Connect the wires to the appropriate terminals as indicated in the diagrams below. Ensure that all connections are correct before switching on. When power is applied the instrument will cycle through a display sequence, see the "Switching on the instrument" chapter for full details of display messages. At the end of the switch on display sequence a "live reading" will be shown on the display if an input is present. A test input or a known sensor input may be used at this stage to check the operation of the instrument. Refer to the "Explanation of functions" chapter for details of user alterable functions.

## Electrical wiring details

Instrument rear panel

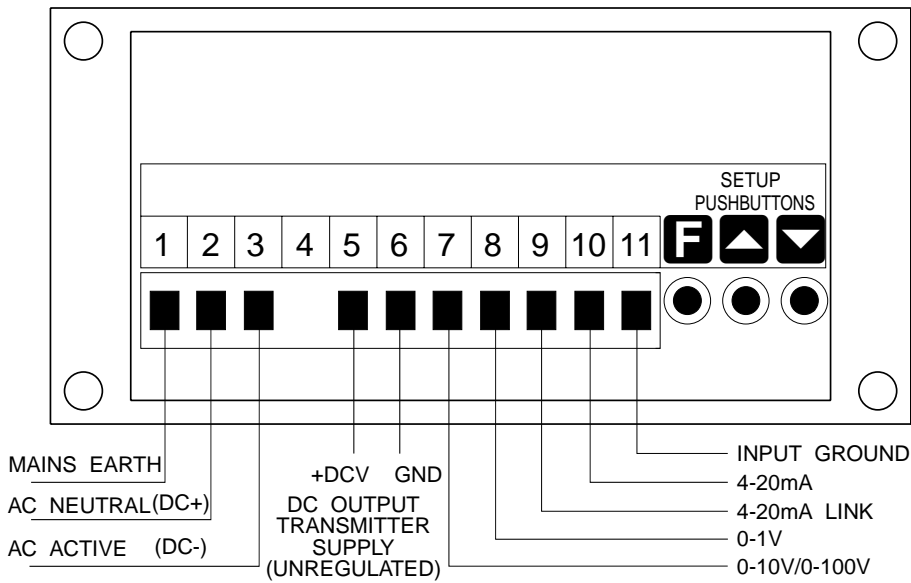

Instrument data label (example)

1 MAINS EARTH	7 0-10V/0-100V INPUT
2 240VAC NEUTRAL	8 0-1V INPUT
3 240VAC ACTIVE	9 4-20mA LINK
5 DC OUTPUT +18 TO 24V	10 4-20mA INPUT
6 DC OUTPUT GROUND	11 INPUT GROUND

0 to 1V	0 to 10V	0 to 100V	4 to 20mA	2 Wire Logic Powered 4 to 20mA Transmitter
5	5	5	5	5
6	6	6	6	6
7	7	7	7	7
8	8	8	8	8
9	9	9	9	9
10	10	10	10	10
11	11	11	11	11

LINK 8 to 11, LINK 8 to 9, LINK 8 to 9, LINK 8 to 9

PM4-IV-240-4E SERIAL No.

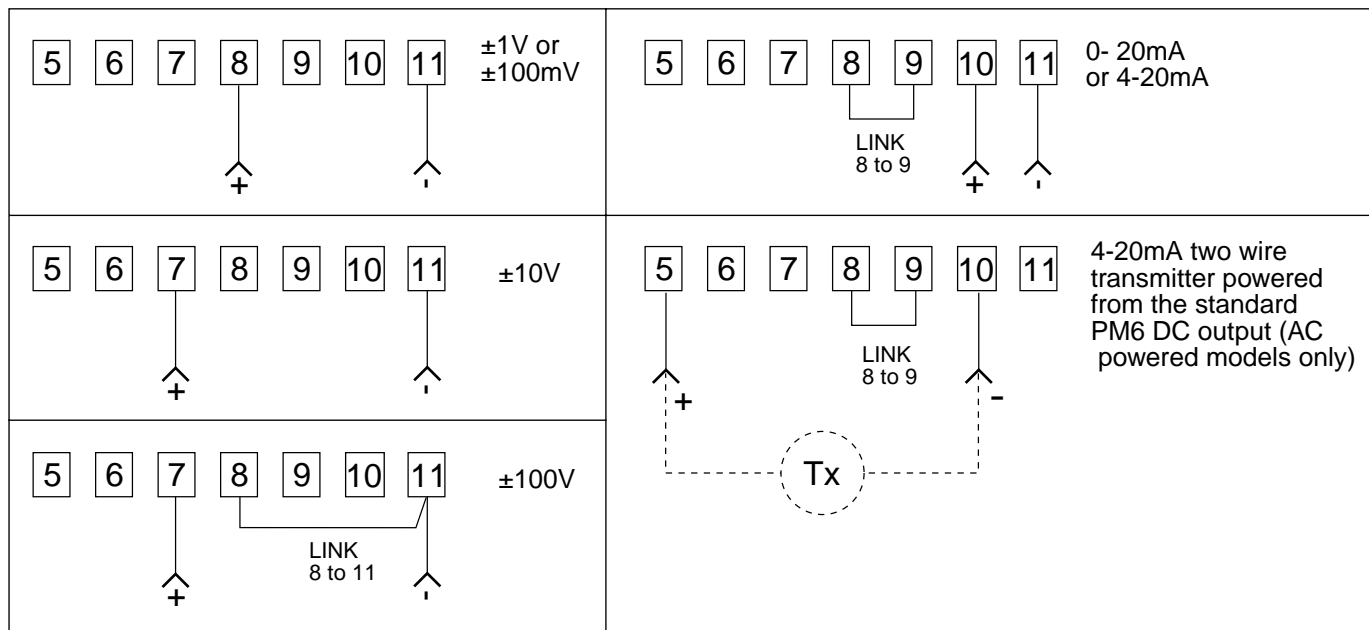

**Examples of sensor connection.**

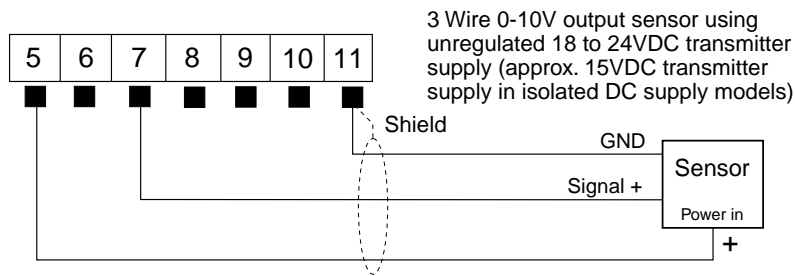
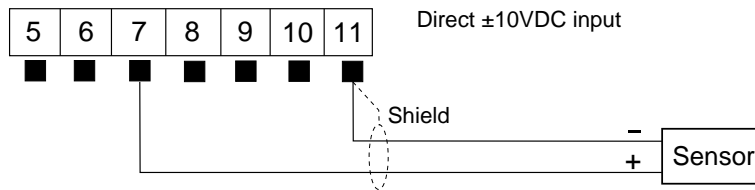
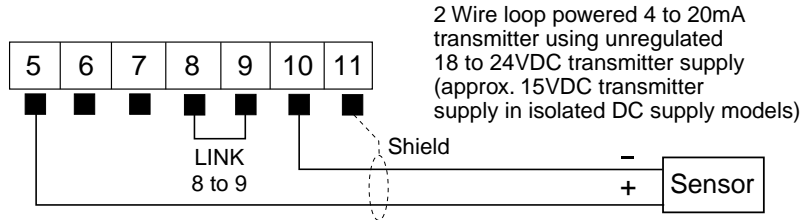
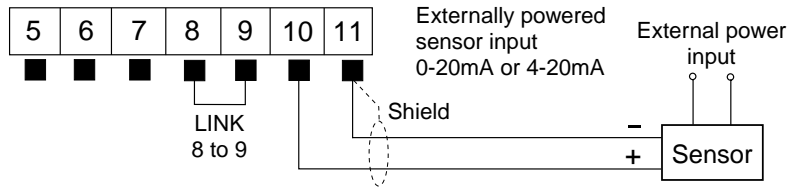

**100mV input link**

To obtain either a 0-100mV or 0-2mA range the x10 link must be in place, see below. Wiring for the 0-100mV range is as per the 0-1V input, wiring for the 0-2mA range is as per the 0-20mA input. When the x10 link is in the USER input mode must be used to calibrate the display. The instrument is not calibrated to be used in any other input mode and therefore the CAL1/SCL1 and CAL2/SCL2 functions must be used to scale the display.

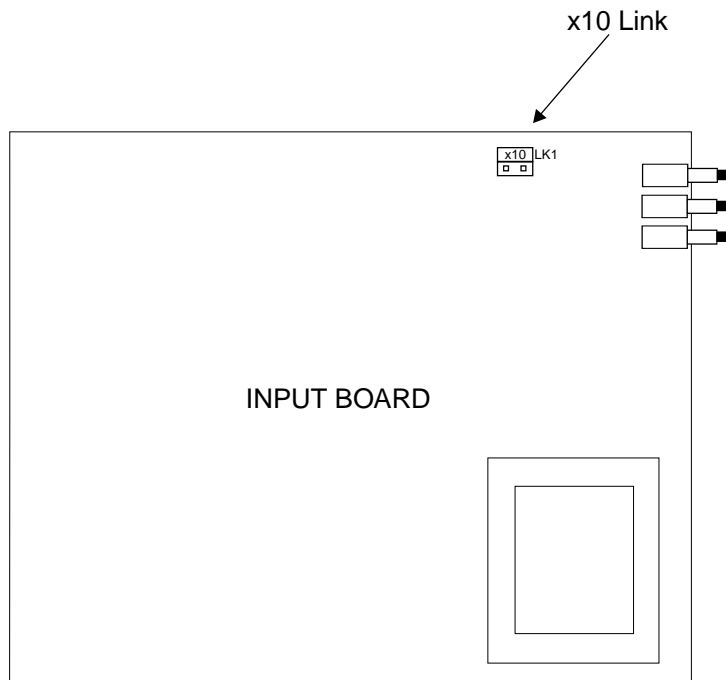

## 5 Switching on the instrument

When the instrument has been electrically connected you can view the status of the input range and measurement mode settings by applying power and watching the display sequence. If you connect a sensor or test voltage/current you will also see the reading obtained from the sensor or test input.

Upon applying power the display automatically scrolls through five displays. The first lights up all LED digits i.e. displays eights. By watching this display you can confirm that all display segments are functioning. The second display is a factory identification message. The third display gives the software revision number of the instrument. The fourth display shows the input range selected, see the “Explanation of functions” and “Setting up the PM6-IV” chapters if this is not the range you require. The fifth display shows the measuring mode being used, again see the “Explanation of functions” and “Setting up the PM6-IV” chapter for details. The sixth display shows the sensor/test input reading, if any input is connected. The switch on display sequence is illustrated in the diagram below.

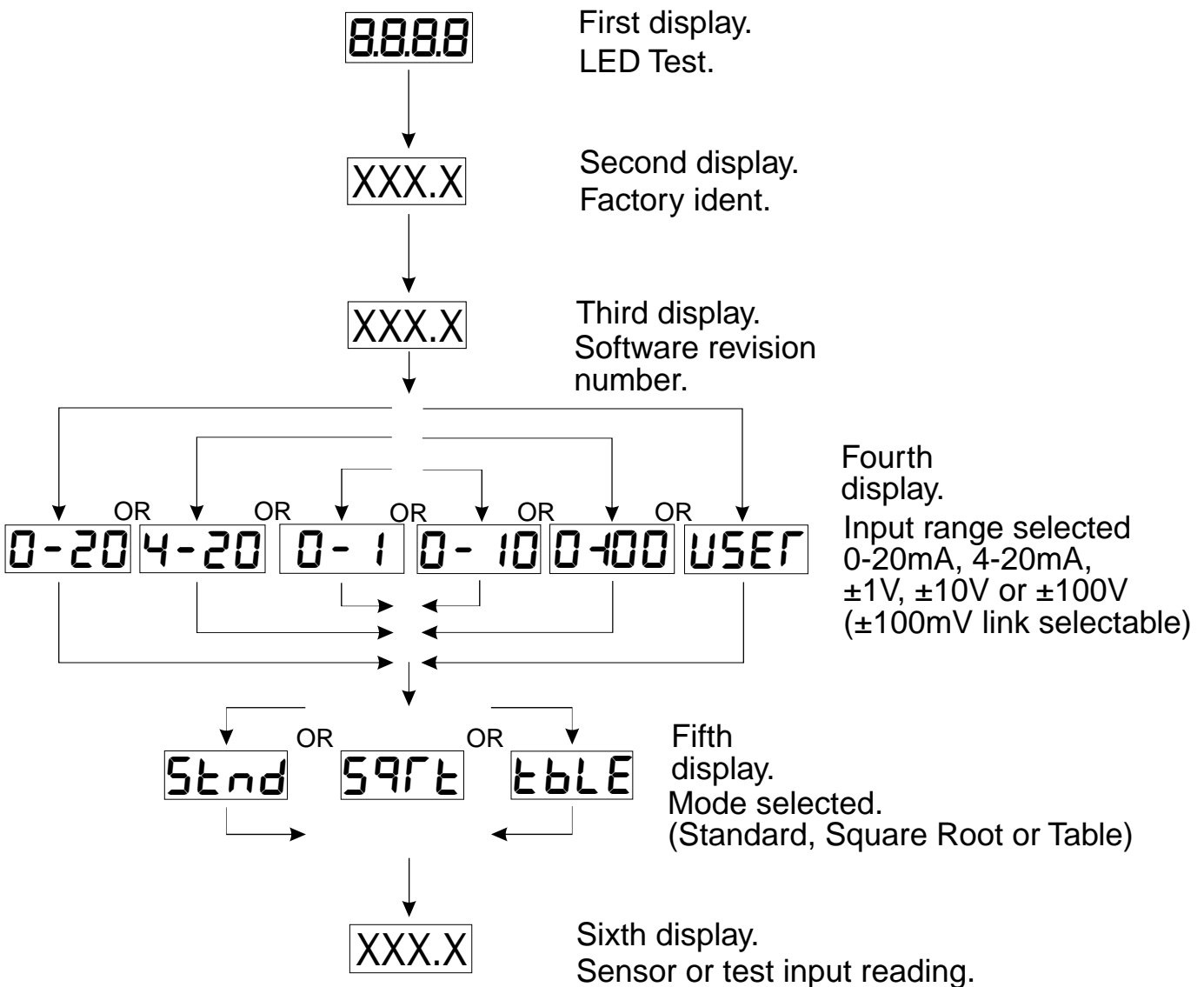

## 6 Explanation of functions

Three measuring modes are available, these are selected at the SLCT function:

**Standard mode** - This mode is indicated by St nd on the display. Use this mode for normal linear measuring conditions.

**Square root mode** - This mode is indicated by SqRt on the display. Use this mode when the square root facility is required in the measurement being made.

**Lineariser mode** - This mode is indicated by t bLE on the display. Use this mode when a non linear input needs to be linearised before being displayed. The use of this mode is described in the "Setting up the lineariser" chapter.

The mode chosen determines how the sensor inputs (input (I NPt ) function) will be interpreted by the instrument. See "Setting up the PM6-IV" chapter for full details on set up procedure for each mode and function. See the function tables on the next page for details of which functions are available in each mode.

Function	Range	Meaning
dr nd	1 to 5000 units	Display rounding - allows the user to set a figure for display rounding. For example if dr nd is set to 10 the display will only show values in multiples of 10 i.e. 0, 10, 20 etc. Display rounding is useful for reducing the instrument resolution without loss of accuracy, in applications where it is undesirable to display to a fine tolerance. The display rounding values will follow the decimal point value e.g. for 1 decimal point place the dr nd values can be set from 0.1 to 500.0 units.
dCpt	0, 0.1, 0.02 or 0.003	Decimal point - allows the user to alter the placement of the decimal point. Displays such as 294.3, 29.43 etc. may be set. The decimal point value must be set prior to calibration scaling.
FLt r	0 to 8	Digital filter - allows the user to alter the input filter level from 0 to 8. The highest setting will give the highest filtering level but it will also give the slowest display response time. Thus a setting of 8 will give a higher filtering level than a setting of 5, but the setting of 5 will give a faster display response. Choose a level which is just high enough to filter out the noise present to ensure optimum response time. A setting of 3 is standard.
brgt	0 to 15	Display brightness - allows the user to set the display brightness level from 0 to 15, where 15 is the highest brightness level.
I NPt	0- 20, 4- 20, 0- 1, 0- 10, 0- 100 or USER	Input selection - allows the user to select one of the input ranges to be used. The input ranges available are: 0 - 20mA (0- 20), 4 - 20mA (4- 20), 0 - 1 Volt (0- 1), 0 - 10 Volts (0- 10), 0 - 100 Volts (0=00) and user (USER). The USER function allows the input limits to be set anywhere within the limits of the other ranges e.g. 3 to 16mA.
CAL 1 & CAL2	n/a	Calibration points - The calibration function is seen only in USER mode where input low and high (0% and 100%) levels are variable. Entering the calibration points allows the instrument to store the actual input signal levels at the input limits.
SCLE	n/a	Scale - Not seen if I NPt is set to USER or if SLCT is set to t bLE. Within the scale function the display values for the input limits are entered, for example if I NPt is set to 4- 20 and SLCT is set to St nd then the values to be displayed at 4mA and at 20mA will be asked for in this function.
OFSt	n/a	Offset - The offset function allows the entry of a single value by which the calibration curve is to be adjusted before being displayed.
SI ZE	2 to 16	Number of lineariser points - Seen only in t bLE mode. This function sets the number of lineariser points to be used in the table.
t bLE	n/a	Lineariser table - Seen only in t bLE mode. This function allows entry of the lineariser values into the table.



Pct 1 & Pct 2	n/a	Percent - The percent function is only seen when setting up the lineariser in USER mode. In this function the 0% and 100% input levels to the lineariser are stored. As with the CAL1 & CAL2 functions in user mode the instrument needs to store the 0% and 100% levels input to the lineariser since these, unlike the preset ranges, are user variable.
UCAL	n/a	Uncalibrate - The uncalibrate function allows the user to reset the functions back to the factory settings. See the "Factory Configuration" section for a table of factory settings and a record of user changes made to these settings.
SLCt	St nd, Sqr t or t bLE	Select measuring mode - from within this function one of the three measuring modes (Standard (St nd), Square root (S9r t) or Lineariser (t bLE)) is selected.

<b>Function Table - St nd or Sqr t mode</b>				
<b>Initial display</b>	<b>Meaning of display</b>	<b>Next display</b>	<b>Default setting</b>	<b>Record your settings</b>
dr nd	Display rounding	Value in memory	1	
dCPt	Decimal point	0, 0.1, 0.02 or 0.003	0	
FLt r	Digital filter	1 to 8 (8 = most filtering)	3	
br gt	Display brightness	1 to 15	15	
I NPt	Input type	0- 20, 4- 20, 0- 1, 0- 10, 0- 100 or USER	4- 20	
SCLE	Display scaling (not seen in USER mode)	EnX & EnY	n/a	
UCAL	Uncalibration	CALCLr	n/a	
SLCt	Operation mode	St nd, Sqr t or t bLE	St nd	
<b>Functions specific to USER mode</b>				
CAL1	Live input calibration first point	SCL1	n/a	
CAL2	Live input calibration second point	SCL2	n/a	
OFSt	Calibration offset	SCLE	n/a	

<b>Function Table - t bLE mode</b>				
<b>Initial display</b>	<b>Meaning of display</b>	<b>Next display</b>	<b>Default setting</b>	<b>Record your settings</b>
dr nd	Display rounding	Value in memory	1	
dCPt	Decimal point	0, 0.1, 0.02 or 0.003	0	
FLt r	Digital filter	0 to 8 (8=most filtering)	3	
br gt	Display brightness	1 to 15	15	
I NPt	Input type	0- 20, 4- 20, 0- 1, 0- 10, 0- 100 or USER	4- 20	
SI ZE	Lineariser points	2 to 16	2	
t bLE	Set table	A 1, Y 1 etc.	n/a	
Pct 1	Calibration 0% (USER mode only)	0P	n/a	
Pct 2	Calibration 100% (USER mode only)	100P	n/a	
SLCt	Operation mode	St nd, Sqr t or t bLE	St nd	

## 7 Setting up the PM6-IV

This section contains descriptions of the setting of each of the available measuring modes and functions, with the exceptions of the user (USER) and lineariser (t bLE) modes. These are dealt with in the “Setting up the USER functions” and “Setting up the lineariser” chapters respectively. A table showing the standard factory configuration for each function with space for the user to record any changes made can be found in the “Explanation of functions” chapter of this manual. When programming the functions they appear on the display in the following order:

- dr nd - Display rounding.
- dCPt - Decimal point.
- FLt r - Digital filter.
- br gt - Display brightness.
- I NPt - Input range selection.
- SCLE - Input scale entry.
- UCAL - Uncalibrate.
- SLCt - Measuring mode selection.

To change a function or measuring mode you will use the three push buttons situated at the rear of the instrument. See below.

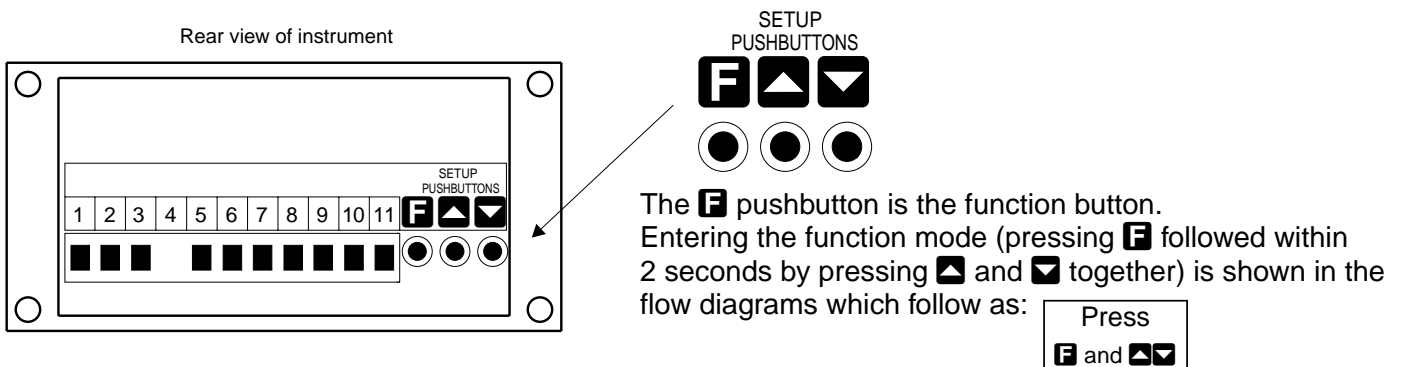

**Entering the function mode** - to make any changes to the function settings you will need to enter the function mode. To enter this mode the power should be applied and a reading present on the display. Press and release the **F** button followed (within 2 seconds) by pressing the **▲** and **▼** buttons together, release the buttons. FUNC will be displayed telling you that you are in the function mode. You can now scroll through the functions by pressing and releasing the **F** button each time you want to change functions. When you arrive at the function you want (as confirmed by the display) the **▲** and **▼** push buttons are used to enter data and change settings. Be careful not to press the **▲** or **▼** push button unless you want to change the setting. As you scroll past the last function (SLCt), the messages FUNC and End will be displayed. Refer to the relevant part of this section for a detailed description of setting up each function and to the “Setup Examples” section for an example of setting up each function.

### 7.1 Setting the display rounding (dr nd)

The display rounding can be set to any positive number the display is capable of showing. To change the setting follow the procedure below.

1. Enter the function mode as described earlier. The messages FUNC followed by dr nd followed by a display with the current display rounding setting will be shown e.g. 5
2. Press and release the **▲** or **▼** push button as needed until the required display is obtained.
3. Having obtained the required display press the **F** button to accept this new setting and enter the next function.

You may now continue to edit other functions or continue pressing and releasing the **F** button until the message FUNC followed by End is displayed and the instrument returns to its normal measuring mode.

## 7.2 Setting the decimal point (dCpt )

The decimal point may be set to none, one, two or three decimal places. These are displayed as:

0 = no decimal points e.g. 2596

0.1 = one decimal point place e.g. 259.6

0.02 = two decimal point places e.g. 25.96

0.003 = three decimal point places e.g. 2.596

To change the setting follow the procedure below.

1. Enter the function mode as described earlier. Scroll through the functions by pressing and releasing the **F** button until dCpt followed by a display with the current decimal point setting is shown e.g. 0.02
2. Press and release the **▲** or **▼** push button as needed until the required display is obtained.
3. Having obtained the required display press the **F** button to accept this new setting and enter the next function.

You may now continue to edit other functions or continue pressing and releasing the **F** button until the message FUNC followed by End is displayed and the instrument returns to its normal measuring mode.

## 7.3 Setting the digital filter (FLt r )

The digital filter setting ranges from 0 (no filtering, fast display response time) to 8 (maximum filtering, slower display response time). To optimise the display response time choose the lowest filter value needed.

To change the filter value follow the procedure below.

1. Enter the function mode as previously described.
2. Scroll through the functions by pressing and releasing the **F** button until FLt r is displayed followed by the current filter setting e.g. 3
3. Use the **▲** or **▼** button to change this value. When the required value is reached press and release the **F** button to accept this new setting and enter the next function.

You may now edit other functions or continue pressing and releasing the **F** button until the message FUNC followed by End is displayed and the instrument returns to its normal measuring mode.

## 7.4 Setting up the display brightness (br gt )

The display brightness function allows the user to set the display brightness to suit the lighting environment and viewing distance required. To change the brightness value follow the procedure below.

1. Enter the function mode as previously described.
2. Scroll through the functions by pressing and releasing the **F** button until br gt is displayed followed by the current filter setting e.g. 15
3. Use the **▲** or **▼** button to change this value. When the required value is reached press and release the **F** push button to accept this new setting and enter the next function.

You may now edit other functions or continue pressing and releasing the **F** button until the message FUNC followed by End is displayed and the instrument returns to its normal measuring mode.

## 7.5 Setting up the input function (I NPt )

The input function holds the input signal range. The PM6-IV has 5 preset input ranges and one user configurable range. The preset ranges are 0 - 20mA, 4 - 20mA, 0 - 1 Volt, 0 - 10 Volts and 0 - 100 Volts. The set up procedure for the preset ranges will be described here. The user range is described in the "Setting up the USER function" chapter.

### Changing the preset ranges

To change the input setting follow the procedure below.

1. Enter the function mode as previously described.
2. Scroll through the functions by pressing and releasing the **F** push button until I NPt is displayed followed by the current input setting e.g. 4- 20
3. Use the **▲** or **▼** push button to select the input range required.
4. When the required value is displayed press the **F** push button to enter this value and move to the next function. The preset range selected has now been set.

You may now edit other functions or continue pressing and releasing the **F** push button until the message FUNC followed by End is displayed and the instrument returns to its normal measuring mode.

## 7.6 Scale (SCLE) function

The scale function allows the display values to be set for the input limits. To alter the scale values follow the procedure below.

1. Enter the function mode as previously described.
2. Scroll through the functions by pressing and releasing the **F** push button until SCLE is displayed.
3. Press the **▲** and **▼** push buttons together. The message En4 will be displayed if the 4 - 20mA range is selected or En0 will be displayed for any other preset range. The old setting will then be displayed.
4. Use the **▲** or **▼** push button to change the old setting to a new reading (the reading you wish displayed when a minimum input level is present).
5. Press and release the **F** push button. The display will now indicate the maximum input level, shown as: En20 or En1 or En10 or E100 depending on the input range set. The old setting will then be displayed.
6. Use the **▲** or **▼** push button to change the old setting to a new reading (the reading you wish displayed when a maximum input level is present).
7. Pressing and releasing the **F** push button will give the SCLE End and FUNC End messages and cause a return to normal measuring mode.

## 7.7 Uncalibrating (UCAL)

The uncalibrating function allows all of the user alterable functions to be reset to factory configuration. To uncalibrate the instrument follow the procedure below.

1. Enter the function mode as previously described.
2. Scroll through the functions by pressing and releasing the **F** push button until UCAL is displayed.
3. Press the **▲** and **▼** push buttons together. The message CAL CLR will be displayed followed by the FUNC End message. The instrument then returns to its normal measuring mode.

## 7.8 Select (SLCt) function

The select function allows the user to change measuring modes. These modes are:

Standard (St nd) - In this mode the inputs are simply scaled, if required, and displayed.

Lineariser mode (t bLE) - a full description of the lineariser mode is given in a separate section "Setting Up The Lineariser".

Square root (SQRt) - see below for description.

## 7.9 Square root mode (SqRt)

When the square root function is used the scaled displayed value follows the square root of the percentage of the full scale input value. The upper and lower input limits are set as normal as are the values to be displayed at these limits. For example if, for a 4 - 20mA input you wish to display 0 at 4mA and 1000 at 20mA the square root function will calculate as follows:

At 20mA (100%) the display will be 1000 i.e.  $\sqrt{1} \times 1000$ .

At 16mA (75%) the display will be 866 i.e.  $\sqrt{0.75} \times 1000$ .

At 12mA (50%) the display will be 707 i.e.  $\sqrt{0.50} \times 1000$  and so on.

The procedure for setting the square root function and changing the limits is as follows.

1. Enter the function mode as previously described.
2. Scroll through the functions by pressing and releasing the **F** push button until SLCt is displayed.
3. Use the **▲** or **▼** push button to change the display to SQRt.
4. Press and release the **F** push button until the FUNC End message is displayed.
5. Re enter the function mode.
6. Scroll through the functions by pressing and releasing the **F** push button until I NPt is displayed.
7. Set the limits and display values as described in the "Setting Up The Input Function" section.

## 8 Setup Examples

This section contains one example of setting up each of the PM6-IV functions with the exception of the user and lineariser functions, these are dealt with in their own sections. It is assumed in all but one case that only one change of function is required, the final example shows the procedure for multiple changes. Following each example is a flow diagram for easy reference. Some of the common button press symbols are described below.

Press **F** and **▲▼**  
Enter function mode by pressing **F** and within 2 seconds pressing both **▲** and **▼** together

Press both **▲** and **▼**  
Press both buttons together i.e. simultaneously

Press & release **F**  
Press **F** once then release

Press & release **▼** until  
Press and release button for small changes in value, also applies to **▲** button

Press & release **F** until  
Repeatedly press and release **F** until the required display is reached

Press & hold **▲** until  
Press and hold the button for large changes in value. This will cause the display to change rapidly, also applies to **▼** button

### 8.1 Setting the display rounding

New setting display rounding of five.

Old setting display rounding of one.

Enter the function mode.

Display shows FUNC followed by dr nd followed by 1 (the old setting).

Press the **▲** push button until 5 is observed on the display

Press and release the **F** push button until the FUNC End message is observed and display returns to normal measuring mode.

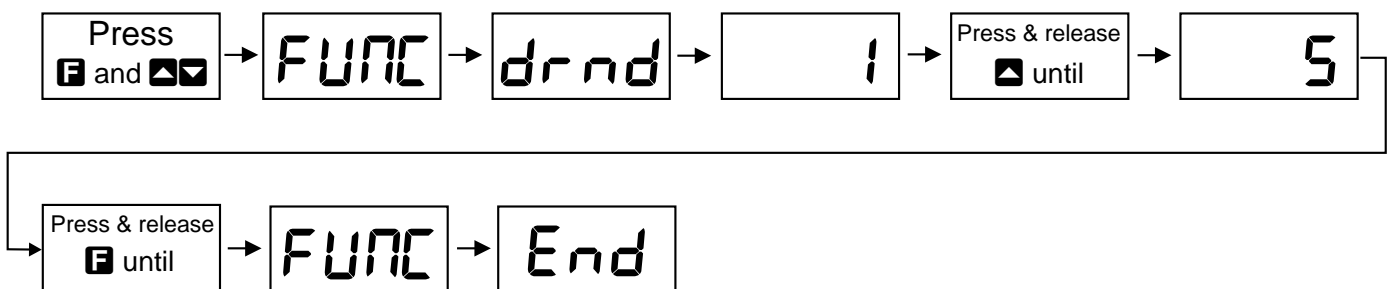

### 8.2 Setting the decimal point

New setting one decimal point place.

Old setting is no decimal points.

Enter the function mode.

Display shows FUNC followed by first function.

Press and release the **F** push button until the display shows dCpT followed by 0 (the old setting).

Press the **▲** push button to get display to 0.1

Press and release the **F** push button until the FUNC End message is observed and display returns to normal measuring mode.

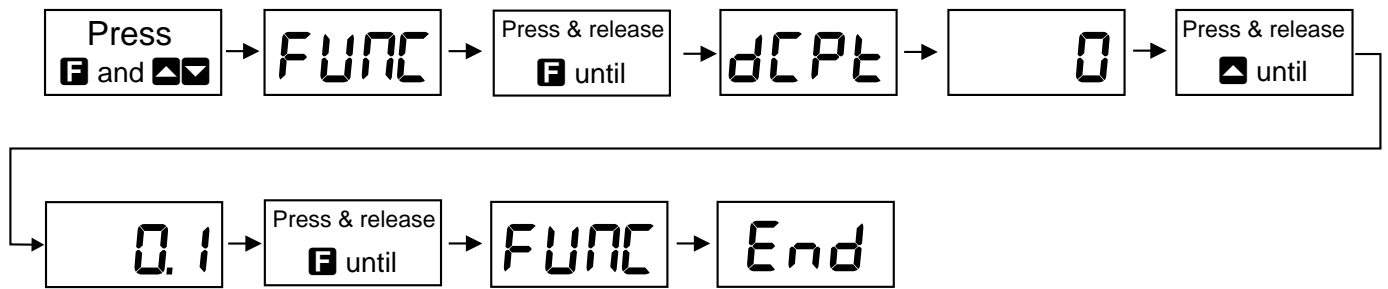

### 8.3 Setting the digital filter

New setting 6.

Old setting 3.

Enter the function mode.

Press and release the **F** push button until the display shows FLt r followed by 3 (old setting).

Press and release the **Δ** push button until 6 is observed on the display. Press and release the **F** push button until the FUNCEnd message is seen and the display returns to normal measuring mode.

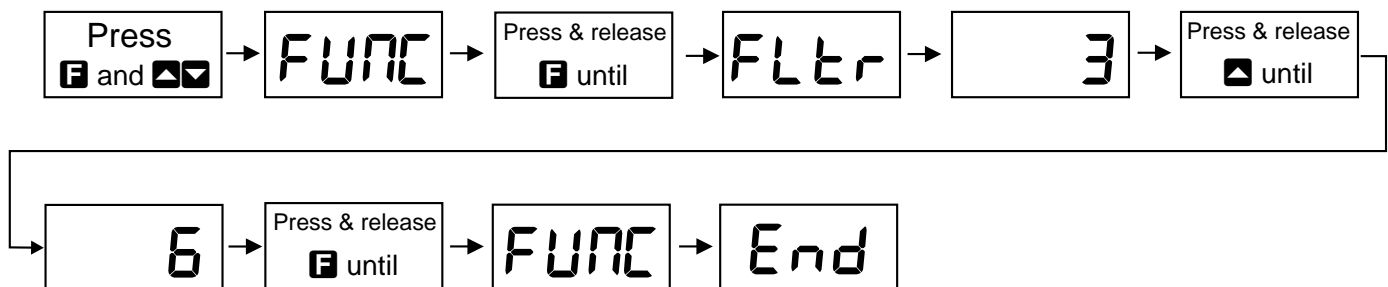

### 8.4 Setting the display brightness

New setting 10.

Old setting 15.

Enter the function mode.

Display shows FUNC followed by first function.

Press and release the **F** push button until the display shows br gt followed by 15 (old setting).

Press and release the **Δ** push button until 10 is observed on the display. Press and release the **F** push button until the FUNCEnd message is seen and the display returns to normal measuring mode.

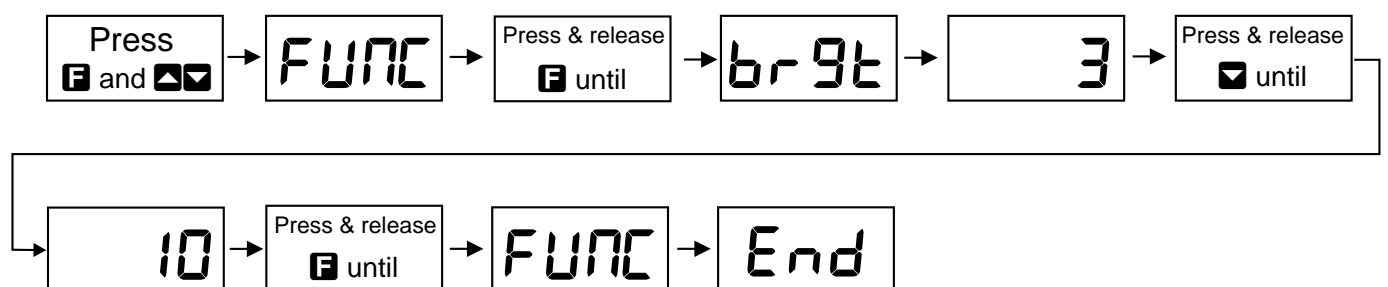

### 8.5 Setting the input range

New range 0 - 20mA

Old range 4 - 20mA

Enter the function mode. Press and release the **F** push button until 1NPlt appears on the display followed 4- 20 (old setting).

Press and release the **Δ** push button until 0- 20 appears on the display.

Press and release the **F** button until the FUNC End message is seen and the display returns to normal measuring mode.

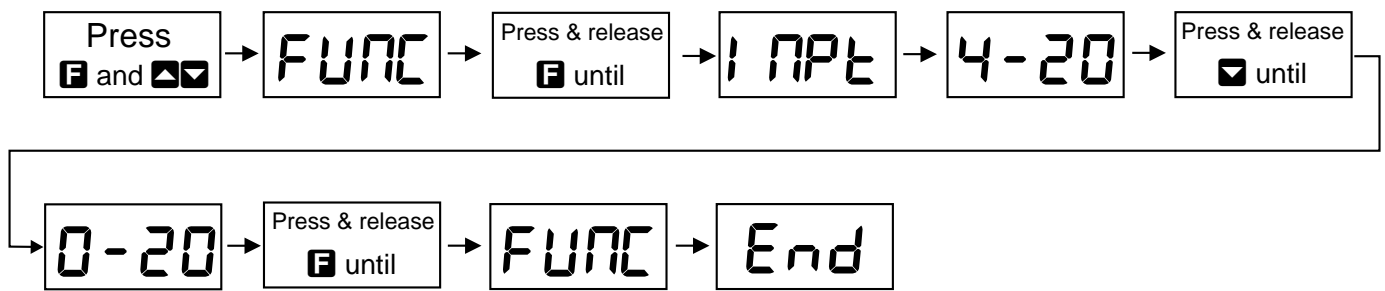

## 8.6 Setting the Scale (SCLE)

New setting 0 - 20mA range, 0mA displayed as - 30, 20mA displayed as 500.

Old setting 4 - 20 mA range, 4mA displayed as 0, 20mA displayed as 1000.

Enter the function mode.

Display shows FUNC followed by first function.

Press and release the **F** push button until the display shows SCLE.

Press the **Shift** and **Shift down** push buttons together, En0 will be displayed followed by 0 (old setting).

Hold the **Shift down** push button until the display changes to - 30.

Press and release the **F** push button until the display shows En20 followed by 1 000 (old setting).

Hold the **Shift down** push button until the display changes to 500.

Press and release the **F** push button until the SCLE End and FUNC End messages are seen and the display returns to its normal measuring mode.

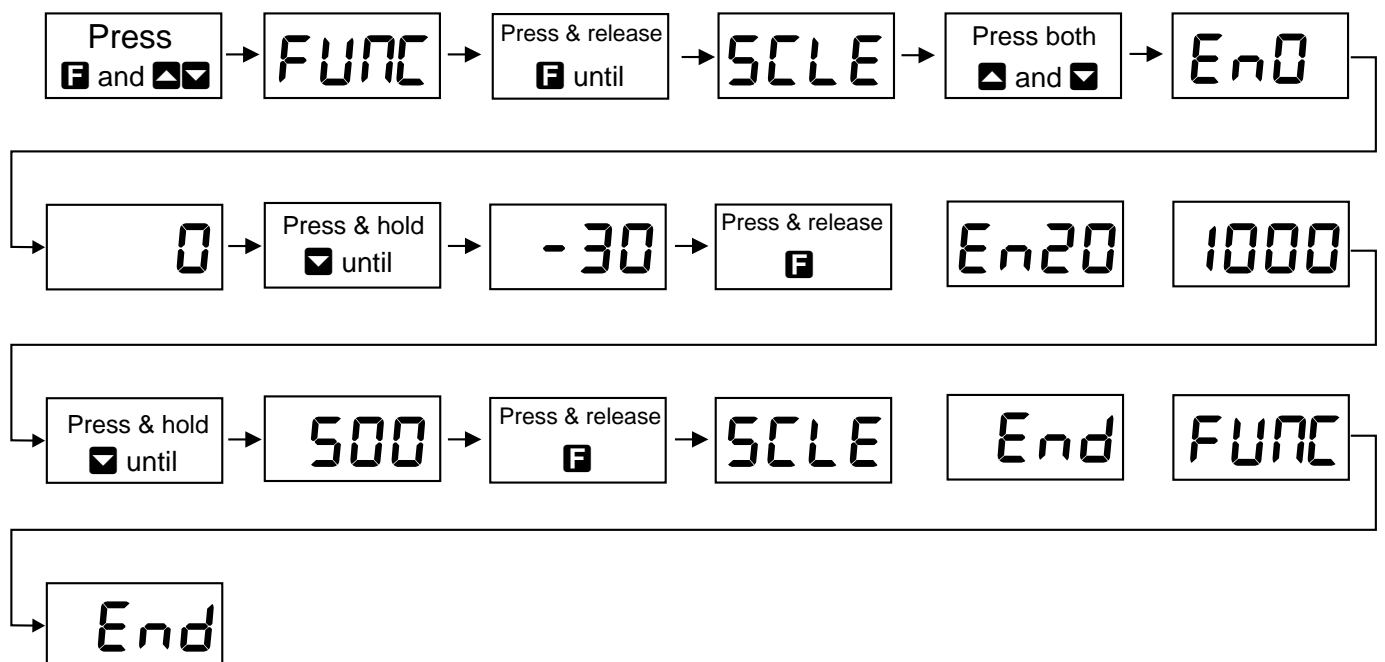

## 8.7 Setting the UCAL (UCAL)

The uncalibrate (UCAL) function may be turned on when you wish to reset the instrument configuration back to the factory settings. The procedure is described fully in the "Setting Up The PM6-IV" section, also refer to flow diagram below.

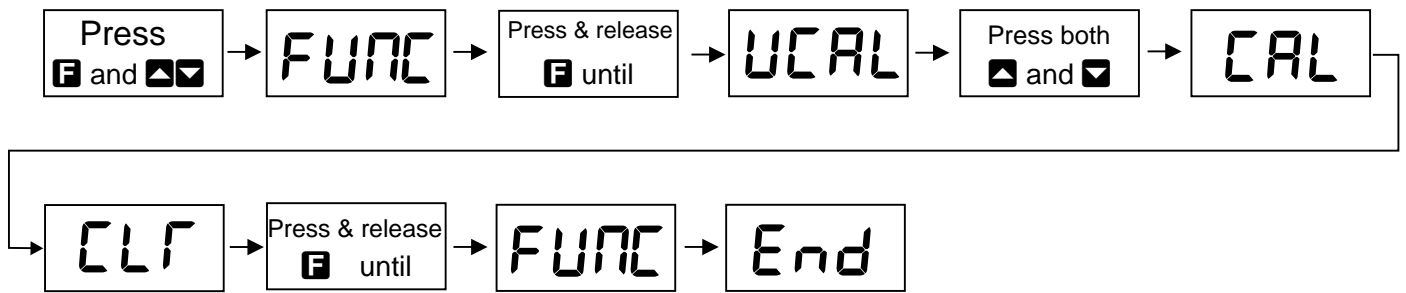

### 8.8 Setting the select (SLCt) function

The select function allows selection of standard(St nd), square root (SqRt ), and lineariser (t bLE) measuring modes. All of the previous examples have been set in the standard mode. The lineariser instructions and example can be found in the “Setting Up The Lineariser” section.

### 8.9 Setting the square root extractor

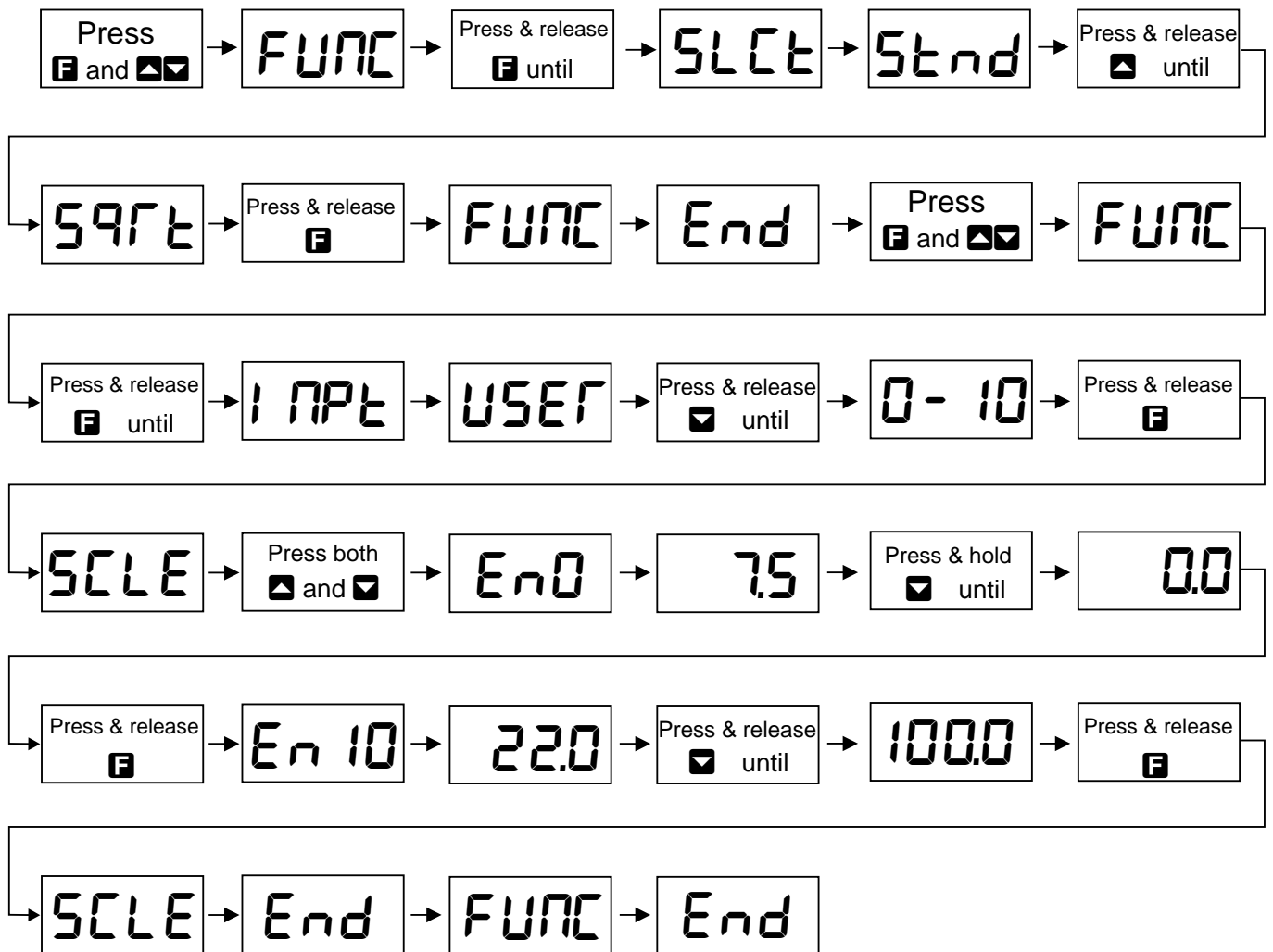

Old setting is Standard St nd (Input user 20 - 80 Volts, display 20 Volts = 7.5, 80 Volts = 2@0).

New setting is Square root SqRt (Input 0 - 10 Volts, display 0 Volts = ) 0, 10 Volts = 10) 0).

Enter the function mode.

Display shows FUNC followed by the first function.

Press and release the **F** push button until the display shows SLCt followed by St nd (old setting).

Use the **[down]** push button to change the display to SqRt

Press the **F** push button again to accept this change. You now need to re-enter the function mode to change the input and display settings as described below.

Enter the function mode.



Display shows FUNC followed by the first function.

Press and release the **F** push button until the display shows 1Npt followed by USER(old setting).

Use the **▼** push button to change the display to 0- 10

Press and release the **F** push button SCLE will be displayed.

Press the **▲** and **▼** buttons together En0 will be displayed followed by 7.5 (old setting). Use the **▼** push button to change this to ) 0

Press and release the **F** push button. En 10 will be displayed followed by 2@0 (old setting). Use the **▲** and **▼** buttons to change this to 10) 0

Press and release the **F** push button . The SCLE End and FUNC End messages are seen and the display returns to normal measuring mode.

### 8.10 Changing multiple settings

In the flow diagram below the filter value is changed from 1 to 2 decimal point places, the digital filter from 6 to 4, the input from 0-20mA to 0-100V and the display values from -30 and 500 to 0 and 800.

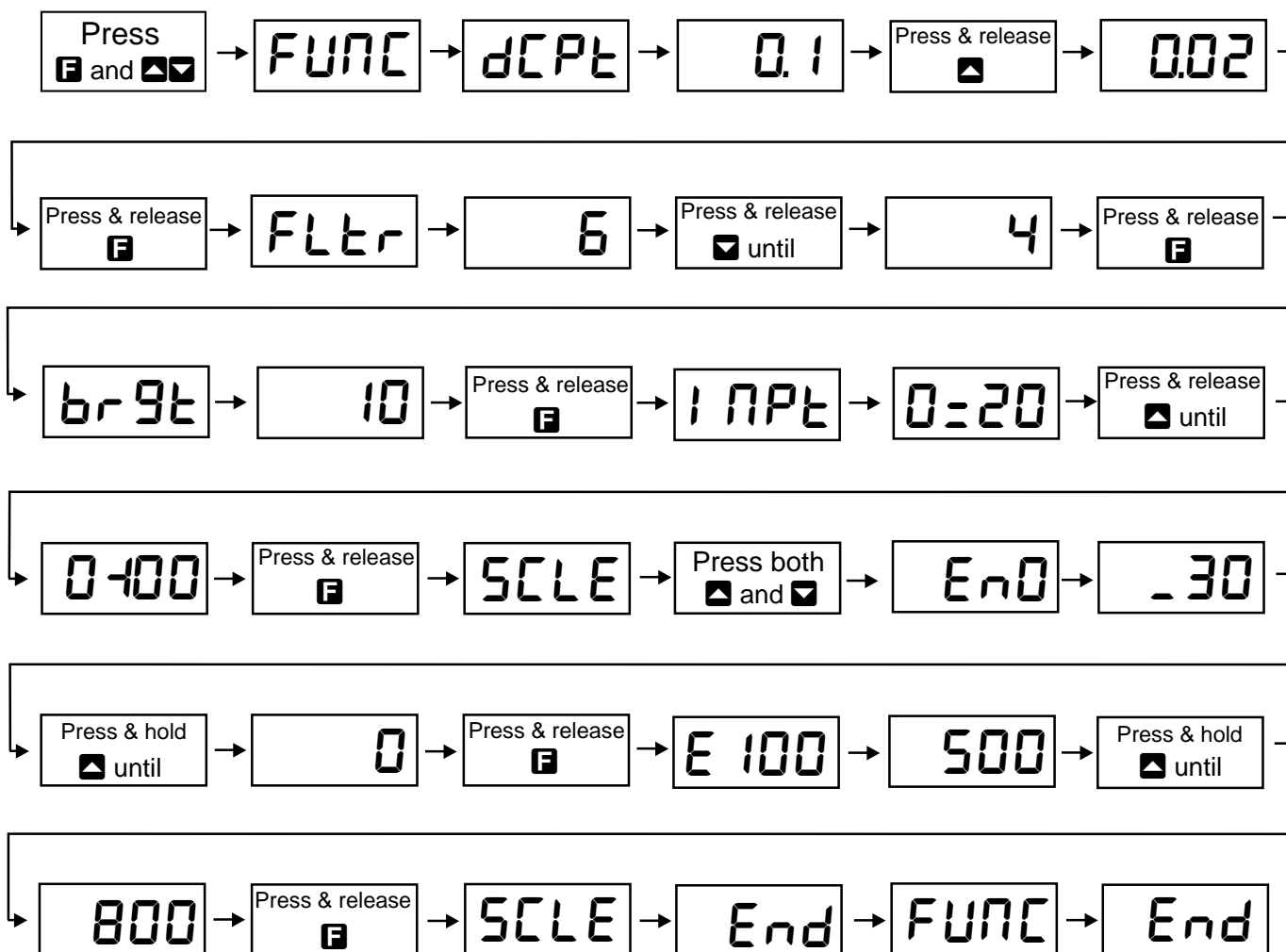

---

## 9 Setting up the USER functions

---

### 9.1 Setting up the user function (USER)

The set up of the user function in lineariser mode is dealt with in the “Setting up the lineariser” chapter. The extra functions which appear as you scroll through the functions are:

CAL1 - First calibration input.

CAL2 - Second calibration input.

OFSt - Offset value.

In setting up the user function you will be setting the limits of the input by applying a signal at both these limits and assigning a value to be displayed for each input. The first limit input is set as CAL1, the value the user wishes displayed for this limit is called SCL1 (scale 1). The second limit input is set as CAL2, the value the user wishes displayed for this limit is called SCL2 (scale 2). For example if our user limits are 2.5 to 25 Volts and we wish the 2.5 Volt level to be displayed as 0 and the 25 Volt level to be displayed as 1000 then CAL1 will be entered as a 2.5 Volt input signal and SCL1 entered as 0, CAL2 will be entered as a 25 Volt input signal and SCL2 entered as 1000.

#### Setting CAL1

1. Apply an input signal of a known value to the instrument.
2. Enter the function mode as previously described.
3. Scroll through the functions by pressing and releasing the **F** push button until I NPt is displayed followed by the old input setting e.g. 4- 20.
4. Use the **▲** or **▼** push button to change this value to User (USER).
5. When USER is displayed press and release the **F** push button. CAL1 will now be displayed. Press **▲** and **▼** together, a reading from the input will be displayed. Check that the input signal level is correct, the display reading for this input will be adjusted at the next step.
6. Press the **F** push button, SCL1 will be displayed followed by the old reading. Use the **▲** or **▼** push button to change this value to the required value i.e. the display value you wish at this input level.
7. When the required value is reached press the **F** push button to accept this new setting. The display will now show CAL1 followed by End. CAL2 will now be displayed. You may now edit CAL2 or continue pressing and releasing the **F** push button until the message FUNC followed by End is displayed and the instrument returns to its normal measuring mode.

#### Setting CAL2

Since CAL1 and CAL2 are independent functions they do not need to be set together, thus CAL2 may be set following the CAL1 setting or set individually, at a later time. The setting procedure is identical to the CAL1 procedure. Note that if setting CAL2 directly after CAL1 then you will be starting from step 6 in the instructions below.

1. Apply an input signal of a known value to the instrument.
2. Enter the function mode as previously described.
3. Scroll through the functions by pressing and releasing the **F** push button until I NPt is displayed followed by the old input setting e.g. 4- 20.
4. Use the **▲** or **▼** push button to change this value to user (USER).
5. When USER is displayed press and release the **F** push button. CAL1 will now be displayed followed by the reading from the input. Press the **F** push button again, CAL2 will be displayed.
6. Press the **▲** and **▼** push buttons together, a reading from the input will be displayed. Check that the input signal level is correct, the display reading for this input will be adjusted at the next step.
7. Press the **F** push button, SCL2 will be displayed followed by the old reading. Use the **▲** or **▼** push button to change this value to the required value i.e. the display value you wish at this input level.
8. When the required value is reached press and release the **F** push button to accept this new setting, the display will now show CAL2 End followed by the FUNC End message.

The instrument then returns to its normal measuring mode.

As shown below setting CAL1 and CAL2 sets the display upper and lower limits corresponding with the input upper and lower limits. Note that CAL1 does not have to correspond with the low input signal or display. Thus the display could be scaled to show a high reading at a low input level if required.

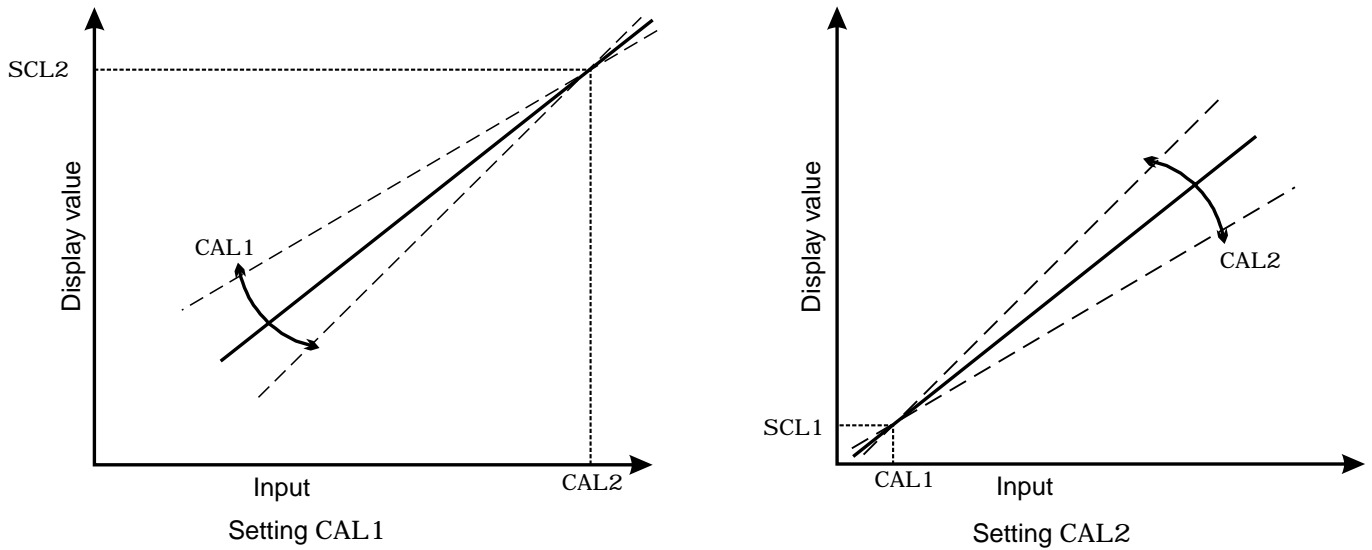

## 9.2 Example of setting the user function

The following example is in standard measuring mode but is equally applicable in square root mode.

New range 20 Volts to 80 Volts (display 20 Volts = 7.5, 80 Volts = 2@0).

Old range 0 - 20mA (Display 0mA = - 3) 0, 20mA = 50) 0).

Apply an input voltage somewhere within the new range (assume the lowest value, 20 Volts). Ensure that the wiring connections have also been changed if needed, see "Electrical installation" chapter.

Enter the function mode. FUNC will be displayed.

Press and release the **F** push button until 1Npt appears on the display followed by the old display (0- 20).

Use the **▲** push button to obtain the USER display message.

Press the **F** push button to obtain a CAL 1 then press **▲** and **▼** push buttons together, a reading from the input will follow.

Confirm that this reading is correct and stable then press the **F** push button.

SCL1 will be displayed followed by the old display setting.

Use the **▲** push button to alter this reading to 7.5

Press the **F** push button again, the CAL1 End message will be seen followed by CAL2 . Press **▲** and **▼** together, an input reading will be displayed.

Apply another input within the range (assume the highest value, 80 Volts). When the input reading is confirmed as correct and is stable press the **F** push button.

SCL2 will be displayed followed by the old display value. Use the **▼** push button to change this reading to 2@0

Press and release the **F** push button. The CAL2 End followed by FUNC End messages are seen and the display returns to normal measuring mode.

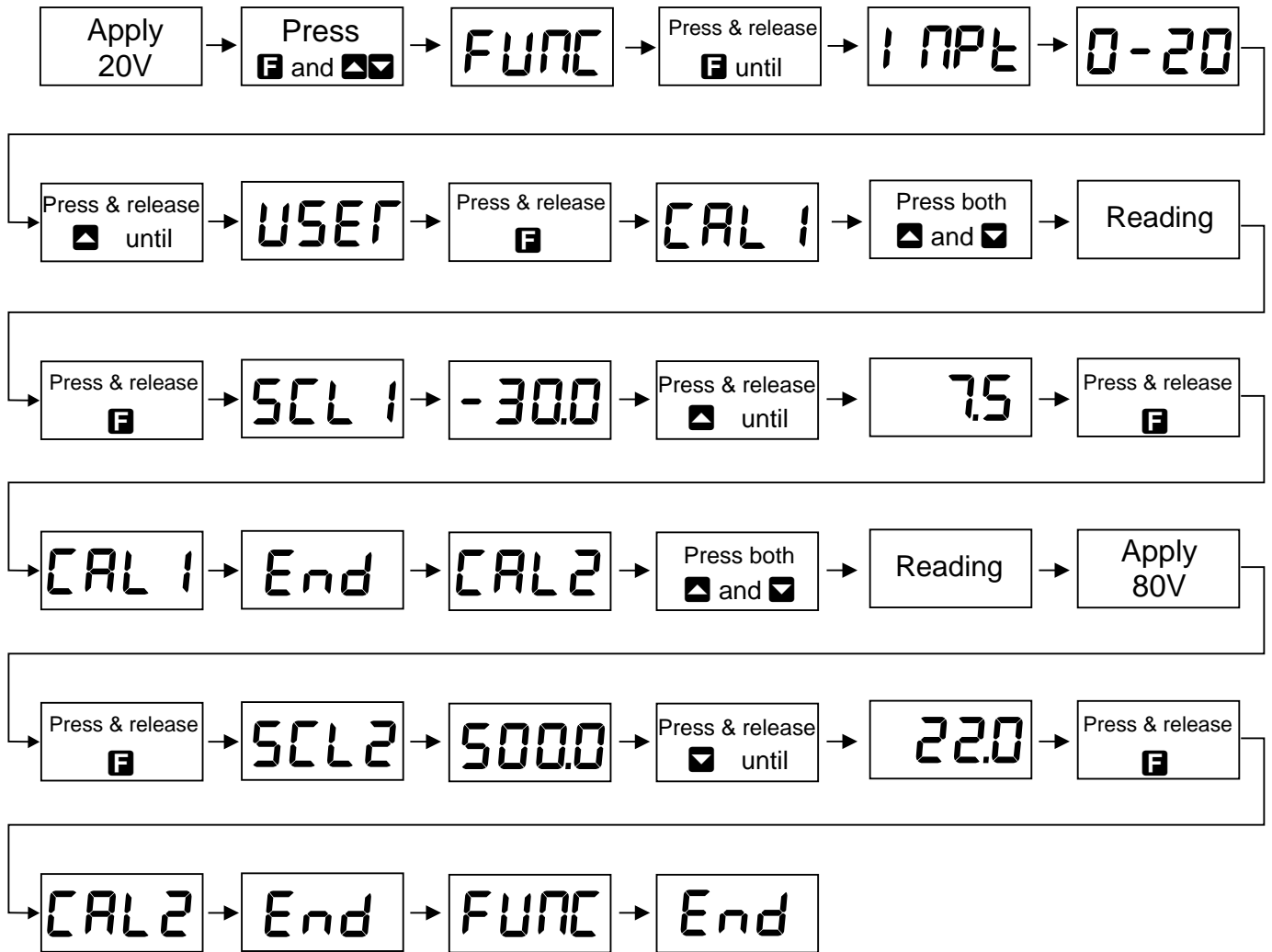

### Setting the offset (OFSt)

The offset function appears only in user mode (standard and square root function). It allows the calibration curve to be offset by a set value. The set value will be added to, or subtracted from the display value along the whole input range. To change the offset simply.

Enter the function mode and scroll through the functions until OFSt appears. Apply a known input to the instrument and press the ▲ and ▼ push buttons together. A reading will be shown, when this is stable press the F push button.

The display will now indicate SCL followed by the old value. Use the ▲ or ▼ button to obtain the required offset.

Press the F push button. The display will show OFSt End followed by FUNC End indicating that the offset calibration is complete. The display now returns to normal measuring mode.

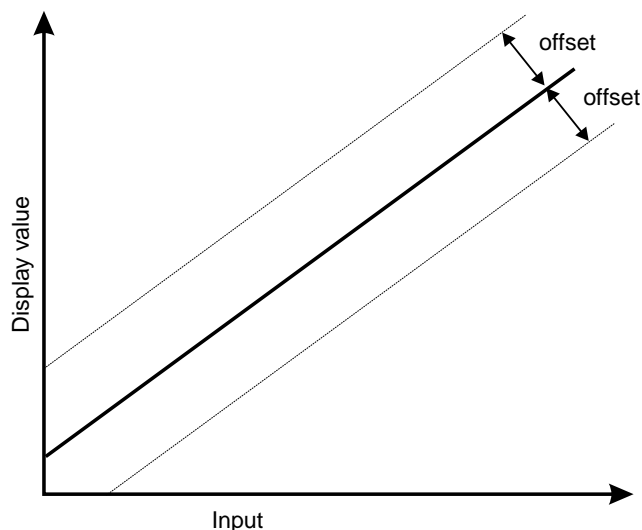

---

## 10 Setting Up The Lineariser

---

### 10.1 Purpose of the lineariser (t bLE) mode

The lineariser is used in situations where it is required that a non linear input be converted to a linear one, e.g. liquid level measurement from an irregularly shaped tank. The inputs to the instrument from the sensor are converted by the lineariser, as programmed by the user. The converted value is the value displayed. Tables are provided in the "Factory Configuration" section to record lineariser settings.

When you enter the lineariser mode you will encounter the following extra displays:

t bLE - table (lineariser) mode.

SI ZE - The size or number of points to be used by the lineariser, selectable from 2 to 16.

A1, A2, A3 etc. - these are the points along the X axis of the lineariser (the display cannot show an X). The A values are measured as a % of full scale.

Y1, Y2, Y3 etc.- these are the corresponding points along the Y axis of the lineariser. The Y values are the ones which will be displayed and are in engineering units e.g. Litres.

Pct 1 & Pct 2 - this is only seen when using the lineariser within the user (USER) function. The 0% and 100% user signal levels are entered at this point.

### 10.2 Input scaling

With the I NPt function set to USER the Pct 1 & Pct 2 functions are used to scale the input, these functions are described more fully later in this chapter.













If the I NPt function is set to anything other than USER e.g. 4- 20 then the input is scaled as a percentage of input range full scale. Using the 4- 20 input as an example the lineariser values A1, A2 etc. would be set as the % of full scale of the 4-20mA input e.g. to enter a 4mA level the value would be entered as 0.0, 8mA as 25.0, 16mA as 50.0, 20mA as 100.0 etc. Similarly for a 0-10V input 0V would be 0.0, 5V would be 50.0 etc.

### 10.3 Using the lineariser

As an example a pressure transmitter with a 4-20mA output is installed near the base of an irregularly shaped tank, see picture which follows, which contains a liquid. 10 linearising points are required to measure the number of litres in the tank. The output from the transmitter will be linear between A9 and A10 since the sides of the tank are straight. Most of the lineariser points are concentrated on the non linear (curved) parts of the tank i.e. the parts of the tank in which the output from the transducer will not be linear. The procedure used is as follows, steps a. to h.

a. Set the I NPt function to USER and the SLCT function to t bLE

b. Set the SI ZE function to 2

c. At the t bLE function press the  and  buttons simultaneously. The message A 1 will appear followed by a number, enter the value 0 via the  or  button. Press , the message Y 1 followed by a value will appear followed by a number, enter the value 0.0 via the  or  button. Press , the message A 2 followed by a value will appear followed by a number, enter the value 100.0 via the  or  button. Press , the message y 2 followed by a value will appear followed by a number, enter the value 100 via the  or  button. This two point 0 to 100% scaling of the display will be used to record the values required for completing the lineariser table.

d. With the tank empty and the sensor connected and in place complete the Pct 1 function (see 10.3 for a description). Fill the tank and complete the Pct 2 function.

e. The tank will need to be gradually emptied whilst the lineariser table record is completed. Decide at what liquid levels the points are to be taken. Partially empty the tank using a flow meter to measure the amount taken from the tank. Record the quantity left in the tank together with the PM6 display reading for this quantity.

f. Repeat the emptying procedure until all 10 points are recorded, the results in this example are shown in the example diagram and table.

g. Change the SI ZE function value to 10.

h. The figures from the written table record now need to be transferred to the instruments lineariser table memory using the t AbL function.

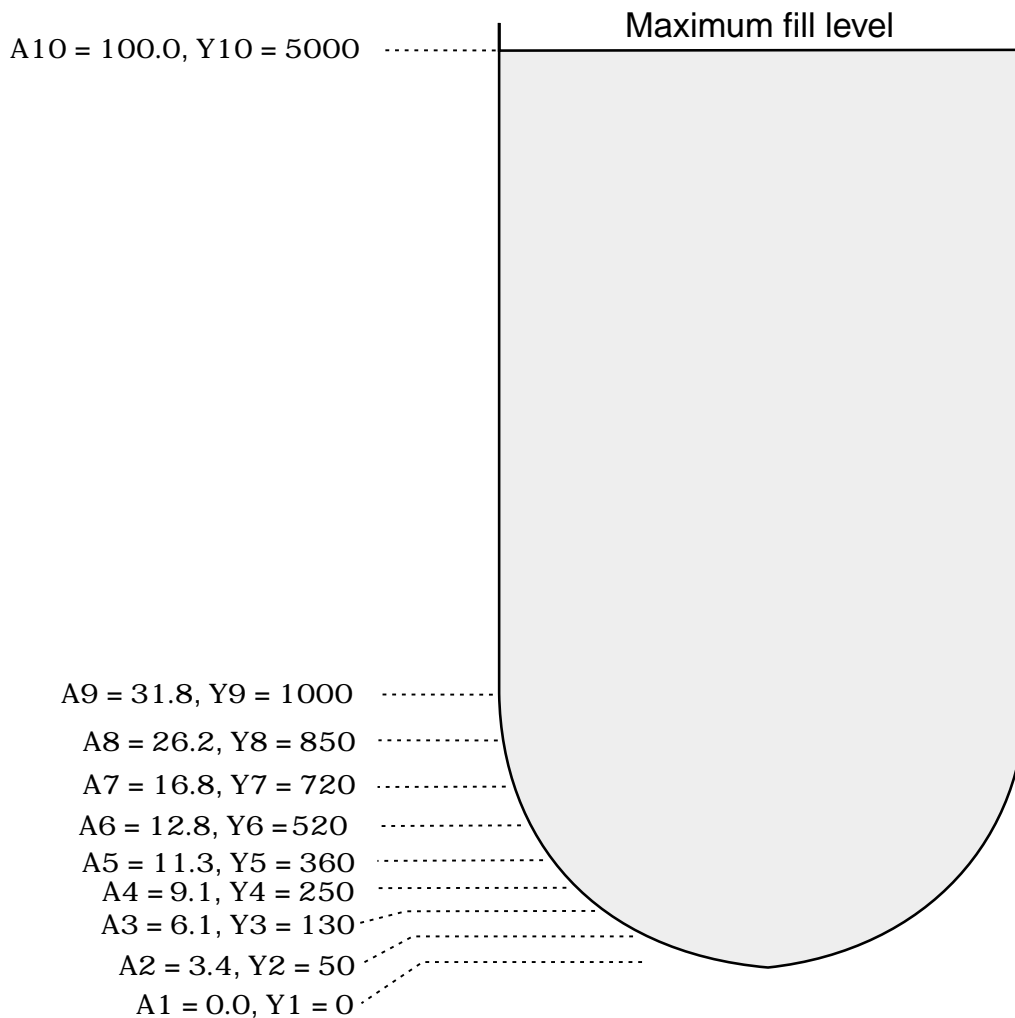

Table showing example values

A Values (% of input)		Y Values (displayed value)	
A1	0.0	Y1	0
A2	3.4	Y2	50
A3	6.1	Y3	130
A4	9.1	Y4	250
A5	11.3	Y5	360
A6	12.8	Y6	520
A7	16.8	Y7	720
A8	26.2	Y8	850
A9	31.8	Y9	1000
A10	100.0	Y10	5000

Blank table fill in your values

A Values (% of input)		Y Values (displayed value)	
A1		Y1	
A2		Y2	
A3		Y3	
A4		Y4	
A5		Y5	
A6		Y6	
A7		Y7	
A8		Y8	
A9		Y9	
A10		Y10	
A11		Y11	
A12		Y12	
A13		Y13	
A14		Y14	
A15		Y15	
A16		Y16	

## 10.4 Using the Pct 1 & 2 functions

If user mode is selected with the lineariser the percent (Pct 1 & 2) functions must be used. Since the low (0%) and high (100%) points are variable in the user function it is necessary to store these percentage points referenced to the actual input signals at these levels.

The sequence for entering values is as follows:

1. Enter the function mode by pressing the **F** button followed (within 2 secs) the **▲** and **▼** buttons together. Step through the functions by pressing and releasing **F** until SLct appears.
2. Press the **▲** or **▼** button to select the lineariser (t bLE) mode. t bLE will be displayed.
3. Press the **F** button to accept t bLE and leave this section.
4. The display will show FUNC then End. Re enter the function mode as described in 1 above.
5. Step through the functions by pressing and releasing **F** until I NPt is displayed. Use the **▲** or **▼** button to select USER.
6. Press **F** to accept the selected input range. SI ZE will appear on the display. Press **F** again t bLE will appear on the display. Press **F** again Pct 1 will appear on the display. Apply the 0% input signal to the instrument.
7. Press **▲** and **▼** together, OP will appear. Ensure that the input to the instrument is the required input for 0% (you will need to measure this, there is no display of the value), wait for 10 seconds then Press **F** again.
8. The display will now show Pct 1 followed by End followed by Pct 2. Put the 100% input signal into the instrument. Press **▲** and **▼** together, 100p will appear. Ensure that the input to the instrument is the required input for 100%, wait for 10 seconds then Press **F** again. The message Pct 2 End followed by FUNC End will be displayed. The instrument then returns to normal measuring mode.

An example of changing the mode from St nd to t bLE and the input range from 4-20mA to user then using the percent function is shown in the following flow diagram.

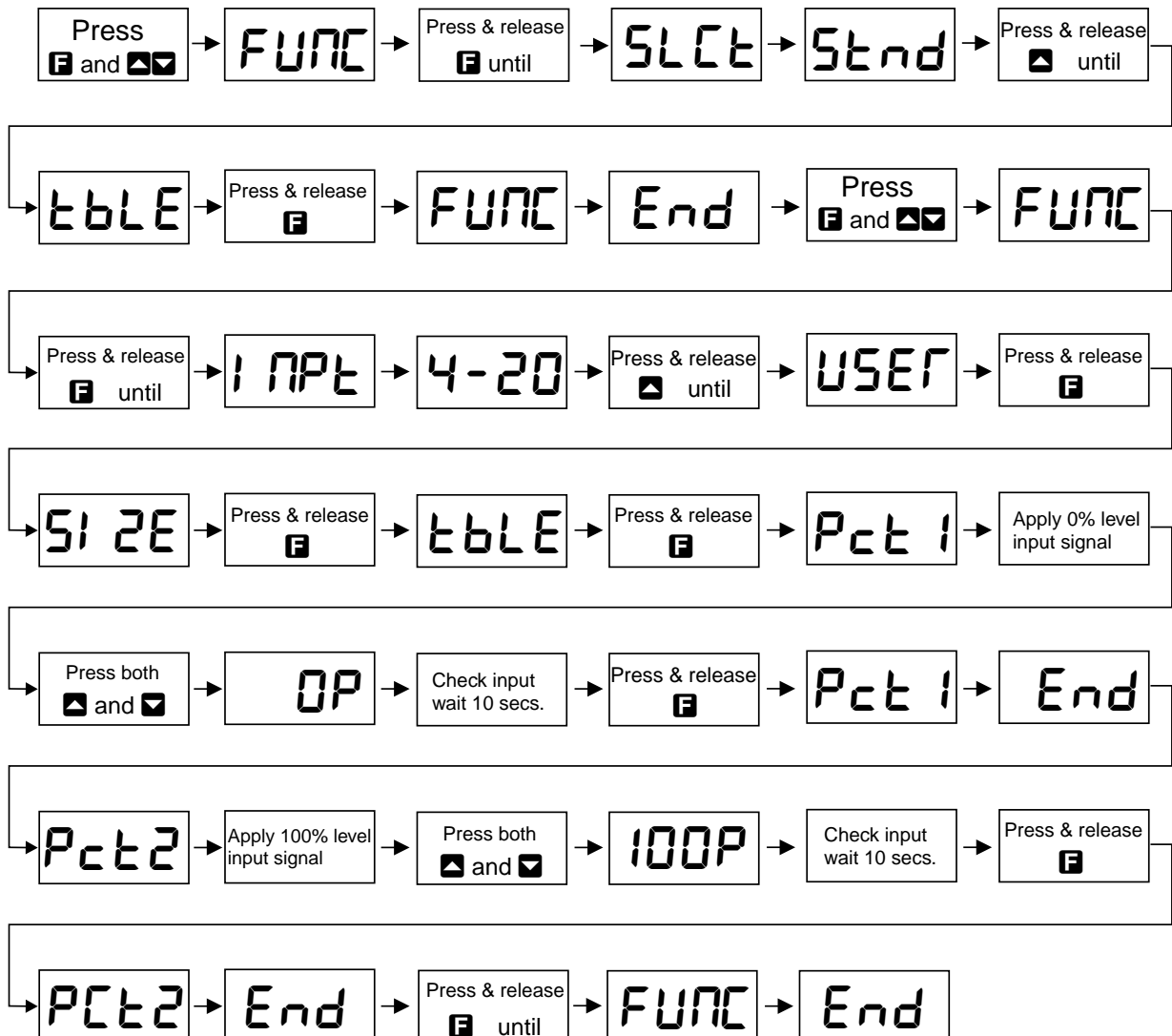

## 10.5 Entering values into the lineariser

The sequence for entering values is as follows:

1. Enter the function mode by pressing the **F** button followed (within 2 seconds) by the **▲** and **▼** buttons together. Step through the functions by pressing and releasing **F** until SLcT appears.
2. Press the **▲** or **▼** button to select the lineariser (t bLE) mode. t bLE will be displayed.
3. Press the **F** button to accept t bLE and leave this section.
4. The display will show FUNC then End. Re enter the function mode as described in 1 above.
5. Step through the functions by pressing and releasing **F** until I NPt is displayed. Use the **▲** or **▼** button to select the required input for the lineariser e.g. 4- 20 or 0- 10
6. Press **F** to accept the selected input range. SI ZE will appear on the display followed by the old size. Use the **▲** or **▼** key to select the number of points for the linearisation process. Press and release the **F** push button, t bLE will be displayed.
7. Press **▲** and **▼** push buttons together.
8. The display will now show A 1 followed by the old value. Use the **▲** or **▼** button to select the required percentage point for A1 (i.e. X1). Press **F** again when the required A1 value has been selected.
9. The display will now show Y1 followed by the old Y1 value. Enter the required value for Y1.
10. Repeat the process for each point. Upon entering the final Y value the message t bLE and End will appear followed by FUNC End. The instrument then returns to normal measuring mode.

For example:

New setting 0.1 - 8.5 Volts user mode with 9 points.

Old setting 4 - 20mA range with 16 points.

The flow diagram will be as follows.

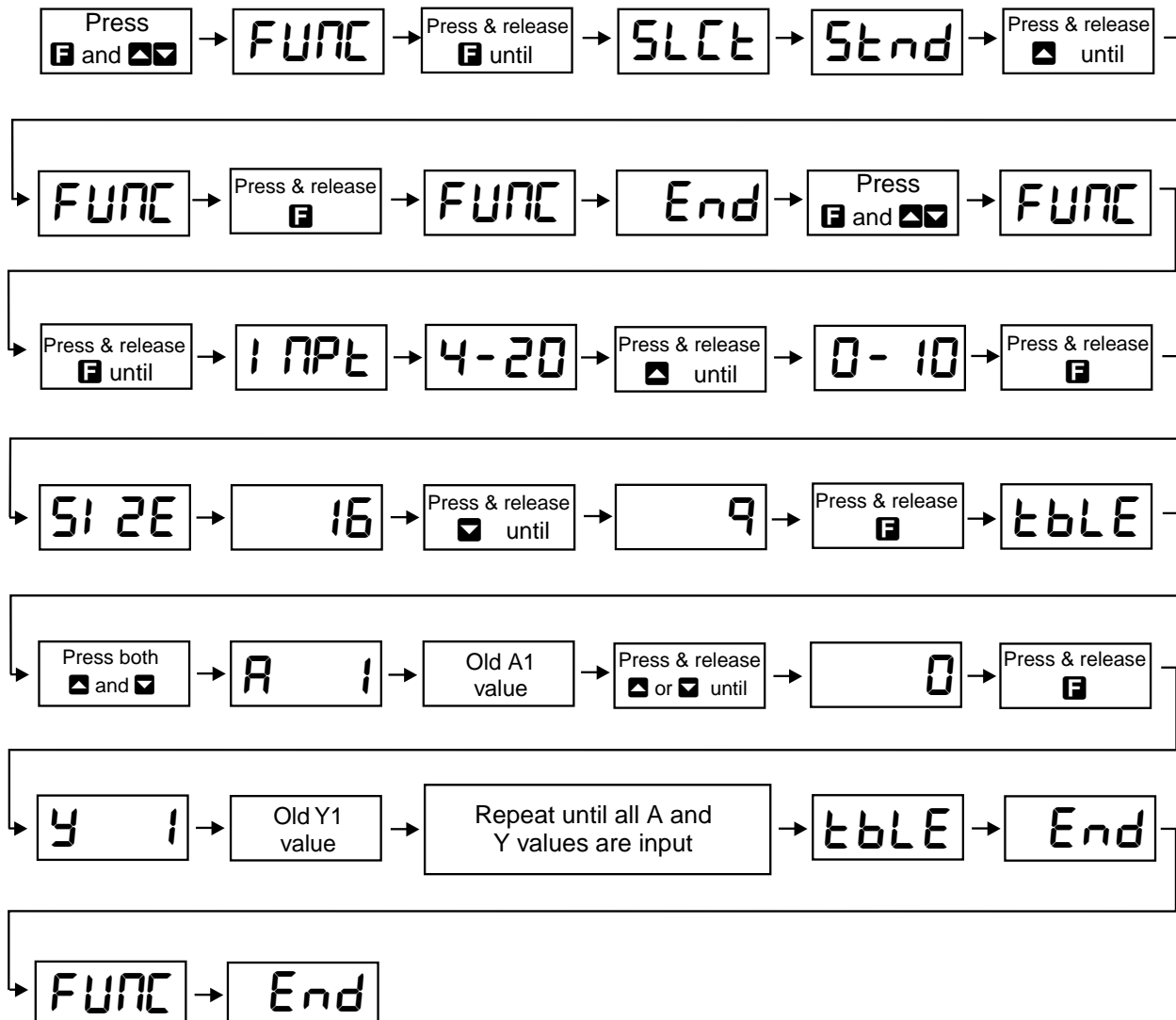



---

## 11 Troubleshooting

---

The following section details some common setup problems encountered by instrumentation meters of the PM6 type. See "Setting Up the PM6-IV" section for details on entering the function mode if you need to check settings.

1. Display not illuminated - check power supply connections.
2. Display shows "- or - " indicates that the number is too big to display i.e. input is too high to display given the configuration figures. Check input from sensor and configuration setup.
3. Row of flashing "- - - " on display indicates input over range. Check input from sensor. If necessary a current or voltage transformer can be used with the instrument for over range inputs.
4. Display shows COP followed by FAI L this message indicates that an internal reset has been generated by the microprocessor. The message should be followed by the "switch on" display sequence and a return to normal measurement. Short term power failure or a spike on the power supply line are possible causes of the reset. Check the power supply to the instrument for drop out or spikes if the reset is occurring regularly enough to be a problem. Also check grounding and shielding of input leads.
5. Display runs through switch on sequence but gives no reading from input - check sensor connections. Check that sensor itself is giving appropriate output for range selected. Check that sensor is connected to appropriate input terminals.
6. Unexpected or erratic display values - check that the sensor is functioning correctly. Check that appropriate measuring mode, input range and display values have been set. Possibility of interference due to noise, check earthing, sensor shielding (if any) and digital filter setting.

---

## 12 Specifications

---

### TECHNICAL SPECIFICATIONS

Input:	DC 4-20mA (-20 to 20mA), 0-2mA (-2 to 2mA) DC $\pm 100\text{mV}$ , $\pm 1\text{V}$ , $\pm 10\text{V}$ or $\pm 100\text{V}$
Input impedance:	105 Ohms nominal DC current range 1M Ohms DC voltage ranges
Accuracy:	0.05% FS when calibrated
ADC resolution:	1 in 20,000
AD conversion:	Dual slope ADC
Sample rate:	4 per second
Memory retention:	Non volatile EEPROM memory
Microprocessor:	MC68HC05 CMOS
Ambient temp:	-40 to 60°C
Humidity:	5 to 95% non condensing
Display types:	4 digit red 20mm digit height
Power supply:	AC 240V, 110V or 24V 50/60Hz DC (wide range) 12 to 48V
Power usage:	AC supply 2VA + transmitter current DC supply 2W + transmitter current
Transmitter supply:	DC output (unregulated, non isolated, max current 25mA) 18 to 24VDC nominal available on AC supply models. On isolated DC supply models the transmitter supply is approx. 15VDC regulated (25mA max.)

### PHYSICAL CHARACTERISTICS

Bezel size:	DIN 48mm x 96mm x 10mm
Case size:	44mm x 91mm x 120mm behind face of panel
Panel cut out:	45mm x 92mm +1mm & -0mm
Connections:	Plug in screw terminals (max 1.5mm diameter wire)
Weight:	400 gms unpacked

### ORDERING CODE

240VAC powered:	PM6-IV-240-4E
110VAC powered:	PM6-IV-110-4E
24VAC powered:	PM6-IV-24-4E
DC powered:	PM6-IV-DC-4E

---

## 13 Guarantee and Service

---

The product supplied with this manual is guaranteed against faulty workmanship for a period of 2 years from the date of dispatch.

Our obligation assumed under this guarantee is limited to the replacement of parts which, by our examination, are proved to be defective and have not been misused, carelessly handled, defaced or damaged due to incorrect installation. This guarantee is VOID where the unit has been opened, tampered with or if repairs have been made or attempted by anyone except an authorised representative of the manufacturing company.

Products for attention under guarantee (unless otherwise agreed) **must be returned to the manufacturer freight paid** and, if accepted for free repair, will be returned to the customers address in Australia free of charge.

When returning the product for service or repair a full description of the fault and the mode of operation used when the product failed must be given.

In any event the manufacturer has no other obligation or liability beyond replacement or repair of this product.

Modifications may be made to any existing or future models of the unit as it may deem necessary without incurring any obligation to incorporate such modifications in units previously sold or to which this guarantee may relate.

**This document is the property of  
the instrument manufacturer  
and may not be reproduced in whole or part without the  
written consent of the manufacturer.**

**This product is designed and manufactured in Australia.**