

PM4-SW

Slidewire / Resistance
Process Monitor/Controller

Operation and Instruction Manual

(2 & 3 wire measurement)

Table of Contents

Introduction	1
Read This First	2
Mechanical Installation	3
Electrical Installation	4
Input connections	5
Alarm Relays	6
Alarm Low Setpoint	6
Alarm High Setpoint	6
Alarm Hysteresis	6
Alarm Relay N/O or N/C Operation	7
Alarm Trip Time	7
Switching Inductive Loads.	7
Output Options	8
Additional Alarm Relays	8
Analog Retransmission	8
DC Voltage Output	8
RS232/RS485 Output	8
Explanation of Functions	10
Setting up the Instrument	14
Remote Input Functions	16
Calibration	18
Input/Output Configuration	21
Hardware Configuration	22
Selecting the Input Range.	22
Configuring the output board	23
Specifications	19
Technical Specifications.	19
Output Options	19
Physical Characteristics.	19
Guarantee and Service	20

1 Introduction

This manual contains information for the installation and operation of the PM4-SW Monitor. The PM4 is a general purpose instrument which may be configured to accept inputs from potentiometers, slidewire and other resistive devices. The PM4-SW measures the resistance from the potentiometer wiper position and translates into engineering units. Selectable ranges are also provided for 2 wire resistive measurements. A standard inbuilt relay provides an alarm/control function, an optional 2nd relay, retransmission and excitation voltage may also be provided.

Unless otherwise specified at the time of order, your PM4 has been factory set to a standard configuration. Like all other PM4 series instruments the configuration and calibration is easily changed by the user. Initial changes may require dismantling the instrument to alter PCB links, other changes are made by push button functions.

Full electrical isolation between power supply, input voltage or current and retransmission output is provided by the PM4, thereby eliminating grounding and common voltage problems. This isolation feature makes the PM4 ideal for interfacing to computers, PLC,s and other data acquisition devices.

The versatile PM4 has various front panel options, therefore in some cases the pushbuttons may be located on the front panel as well as the standard rear panel configuration.

The PM4 series of Panel Mount Monitors are designed for high reliability in industrial applications. The high brightness LED display provides good visibility, even in areas with high ambient light levels. The high contrast LCD displays provide good visibility and are ideal for battery powered applications.

2 Read This First

Your new PM4 monitor has been supplied factory configured (unless otherwise specified), as follows:

Input:	3 wire slidewire
Calibration:	0 to 1000
Relay 1 Low Setpoint:	Off
Relay 1 High Setpoint:	Off
Relay 1 Status:	High Alarm
Relay 1 Hysteresis:	1
Relay 1 Trip Time:	0
Relay 1 Action:	N/O (ie, de-energised when no alarm)
Decimal Point:	0
Display Rounding:	1
Digital Filter:	3 (range 0-8. ie, 0=min & 8=max)
Remote Input:	Set to "NONE" (see section on remote input)

Options (when fitted)

Relay 2:	(same settings as Relay 1)
Retransmission Type:	4 to 20mA standard (0-1V & 0-10V by internal link selection)
Retransmission Low:	0
Retransmission High:	1000
Excitation Voltage:	Isolated ± 12 VDC (24V) or ± 5 V (10V) internal link selection

Input/output Configuration

If you need to change the input configuration or output type from 4 to 20mA to DC volts, proceed as follows:

- Remove plug-in input terminal(s).
- Unscrew 4 x 2g self tapping screws from back cover.
- Remove back cover.
- Loosen earth screw.
- Slide out the printed circuit board.
- Configure PCB links as shown in section "Hardware Configuration".
- Slide printed circuit board back into the instrument case.
- Make sure the earth screw is tightened.
- Refit and secure back cover and plug-in terminals.

3 Mechanical Installation

If a choice of mounting sites is available then choose a site as far away as possible from sources of electrical noise such as motors, generators, fluorescent lights, high voltage cables/bus bars etc. An IP65 access cover which may be installed on the panel and surrounds is available as an option to be used when mounting the instrument in damp/dusty positions. A wall mount case is available, as an option, for situations in which panel mounting is either not available or not appropriate. A portable carry case is also available, as an option, for panel mount instruments.

Prepare a panel cut out of 45mm x 92mm +1 mm / -0 mm (see diagram below). Insert the instrument into the cut out from the front of the panel. Then, from the rear of the instrument, fit the two mounting brackets into the recess provided (see diagram below). Whilst holding the bracket in place, tighten the securing screws being careful not to over-tighten, as this may damage the instrument.

Hint: use the elastic band provided to hold the mounting bracket in place whilst tightening securing screws.

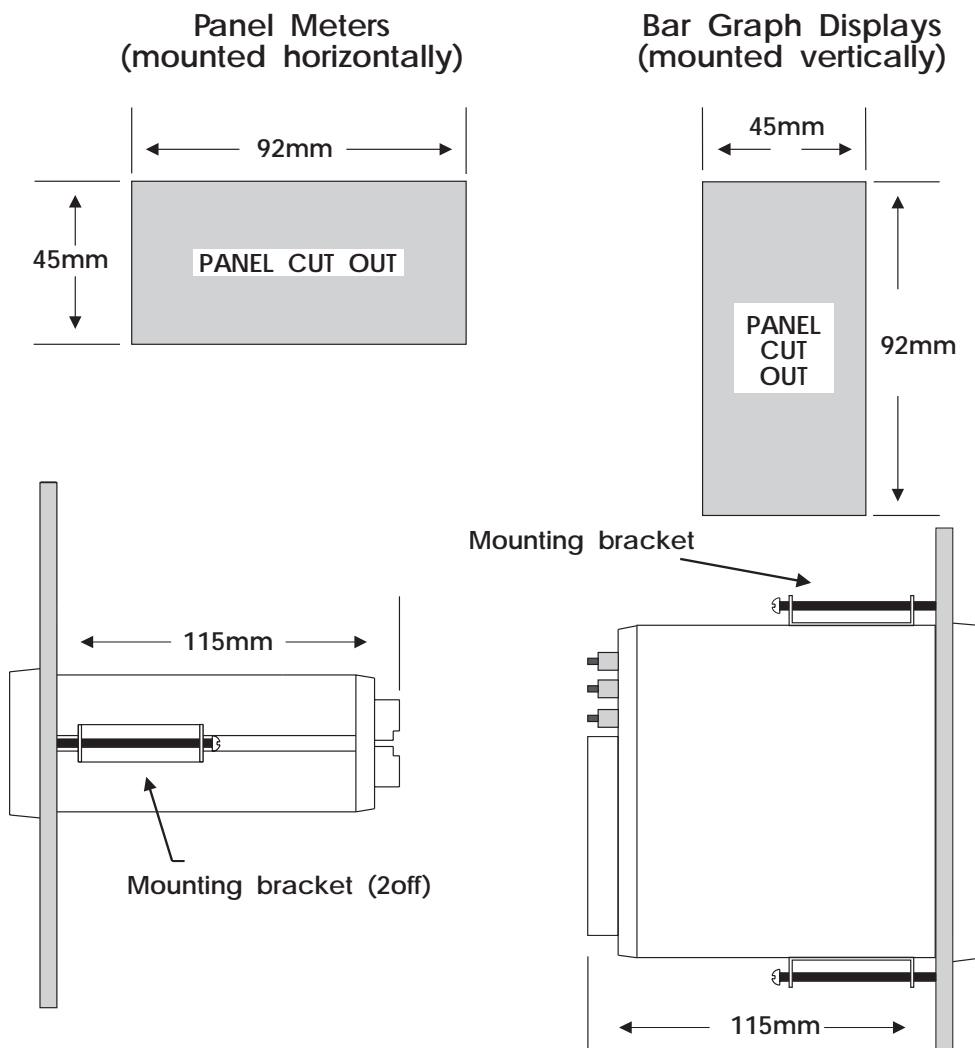

Side view of mounting panel

4 Electrical Installation

The PM4 Panel Meter is designed for continuous operation and no power switch is fitted to the unit. It is recommended that an external switch and fuse be provided to allow the unit to be removed for servicing.

The terminal blocks allow for wires of up to 1.5mm to be fitted. Connect the wires to the appropriate terminals as indicated below. Refer to other details provided in this manual to confirm proper selection of voltage, polarity and input type before applying power to the instrument. When power is applied to the instrument an initial display of **8888** followed by other status displays indicates that the instrument is functioning.

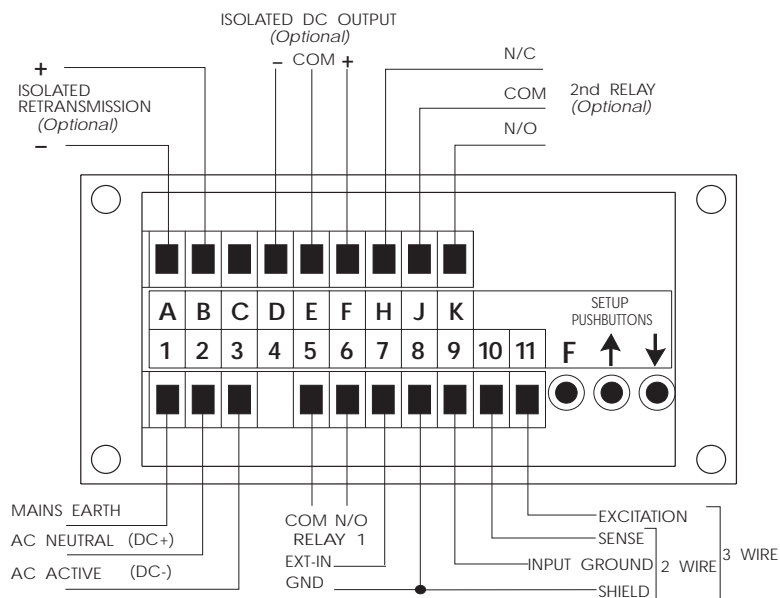

Instrument Rear Panel

 AMALGAMATED INSTRUMENT CO PTY LTD 5/28 LEIGHTON PL, HORNSBY. NSW 2077 AUSTRALIA PH: (02) 476 2244 FAX: (02) 476 2902			
1	MAINS EARTH	OPTIONAL OUTPUTS	
2	240VAC NEUTRAL	A	OUTPUT V/I -
3	240VAC ACTIVE	B	OUTPUT V/I ++
5	RELAY 1 COM	C	
6	RELAY 1 N/O	D	DC VOLTS O/P -
7	EXT IN	E	DC VOLTS O/P GND
8	GROUND	F	DC VOLTS O/P ++
9	INPUT GROUND	H	
10	SENSE	J	RELAY 2 COM
11	EXCITATION	K	RELAY 2 N/O
MODEL No: PM4-SW-240-4E		SERIAL No:	

Instrument Data Label (example)

4.1 Input connections

3 Wire Connection

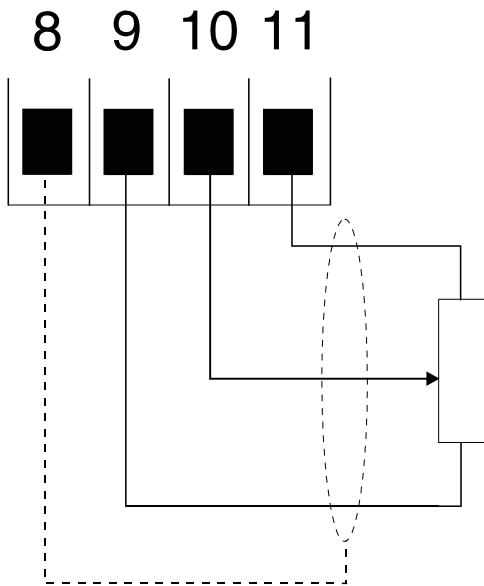

2 Wire Connection

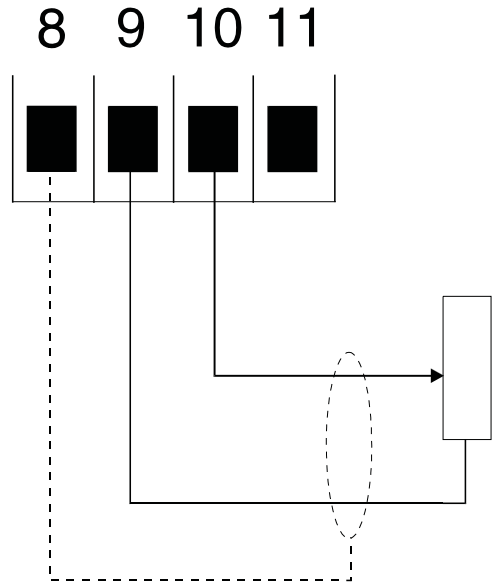

5 Alarm Relays

The PM4 is provided with 1 alarm relay. An optional totally independent 2nd alarm relay may also be provided (up to 7 relays are available on selected models). These are designated **A1** and **A2**. Each alarm has the following parameters which may be set by the user:

1. Low trip point, adjustable in measurement units.
2. High trip point, adjustable in measurement units.
3. Alarm hysteresis, adjustable in measurement units.
4. Alarm trip time, adjustable in seconds.
5. N/O or N/C relay operation

The alarm operates in the following way:

If the measured value is above the High Trip Point, or below the Low Trip Point, the alarm trip timer starts. This timer is reset if the measured value drops below the High Trip Point or above the Low Trip point. When the alarm trip timer's time exceeds the Trip delay time, the alarm is operated.

When the alarm has tripped, the measured value is compared to the High Set Point less the Hysteresis value and the Low Set Point plus the Hysteresis value. If it is less than the High Set Point less the Hysteresis value and greater than the Low Set Point plus the Hysteresis value, the alarm is reset.

5.1 Alarm Low Setpoint

The low setpoint may be programmed to operate the alarm relay when the measured value falls below the set value. If the low setpoint is not required, it may be set to **OFF** in the setup mode by pressing, then releasing, **▲** and **▼** simultaneously. The instrument is configurable for each relay to have a low and a high setpoint, so the relay may be triggered if the reading deviates outside of the setpoint limits.

5.2 Alarm High Setpoint

The high setpoint may be programmed to operate the alarm relay when the measured value exceeds the set value. If the high setpoint is not required, it may be set to **OFF** in the setup mode by pressing, then releasing, **▲** and **▼** simultaneously.

5.3 Alarm Hysteresis

The hysteresis, or deadband, value is used to prevent too frequent operation of the alarm relay when the measured value stays close to the setpoint. The hysteresis value is common to the high and low relay action for each alarm.

Hysteresis Operation Examples:

If the alarm high setpoint is set to 100 and the alarm hysteresis is set to 10 then the alarm will trip when the display reading is above 100 and will not reset until the display reading falls below 90 (high setpoint minus the hysteresis value). Similarly if the alarm low setpoint is set to 50 and the alarm hysteresis is set to 10 then the alarm will trip when the display reading is below 50 and will not reset until the display value is above 60 (low setpoint plus hysteresis value).

5.4 Alarm Relay N/O or N/C Operation

Each alarm may be programmed to operate as a normally open (N/O) or normally closed (N/C) device. A N/O relay is de-energised when no alarm condition is present and is energised when an alarm condition is present. A N/C relay is energised when no alarm condition is present and is de-energised when an alarm condition is present. The N/C mode is useful for power failure detection.

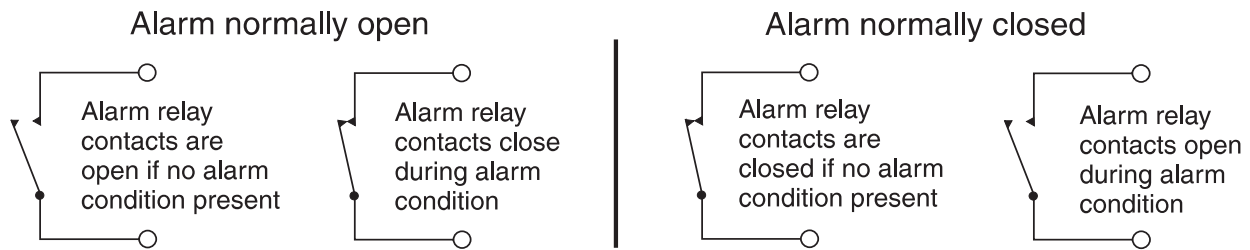

5.5 Alarm Trip Time

The alarm trip time determines how long the measured value has to be above the high set point or below the low set point before the alarm relay is tripped. This can be used to prevent false alarms on noisy inputs. The value is set in seconds, with a range of 0 - 60 seconds. For normal operation a delay of three to five seconds is suitable.

5.6 Switching Inductive Loads

If the alarm relay is to be used to switch an inductive load, such as a solenoid, it is advisable to use a suppressor circuit either across the load or across the relay contacts. Switching inductive loads without a suppressor circuit can cause arcing at the relay contacts resulting in electrical interference and wear on the contacts. A typical suppressor circuit consists of a 100Ω resistor in series with a 0.1µF capacitor, this circuit is then placed across the load or relay contacts. Ensure that the resistor and capacitor are of sufficiently high rating to cope with the voltage and current encountered.

6 Output Options

The basic PM4 is provided with a single alarm relay output. Optional outputs may be provided as follows:

6.1 Additional Alarm Relays

The 2nd alarm relay has the same programmable functions and specifications as the 1st (standard) alarm relay (note up to 6 extra relays are available for some models). The programming messages are automatically updated to include settings for the additional relay(s).

6.2 Analog Retransmission

The isolated analog retransmission output may be user configured to give an output of 4-20mA, 0-1V or 0-10V without the need to recalibrate the instrument. Other output ranges may be provided (consult sections on hardware configuration). The output limits may be programmed to correspond to any points within the measuring range of the instrument. See *FEE* - and *FEE* ~ functions in the “Explanation of Functions” chapter for a description of setting up retransmission.

6.3 DC Voltage Output

An isolated DC voltage output is available to power external transducers etc. The standard output is $\pm 12V$ (24V), the output may be changed to a $\pm 5V$ (10V) by a PCB link selector.

Note: where a 24V DC output is required connect between +12V and -12V (+5V and -5V for 10V outputs).

6.4 RS232/RS485 Output

An RS232 or RS485 output is available with selectable parameters such as baud rate (300 to 9600), parity (none, even or odd), number of data bits, alpha character select etc. Setup instructions for RS232/RS485 operation will be given either in a manual appendix or a manual addendum if this option is fitted.

Note: When this option is supplied the analog output is not available.

Explanation of Functions

The PM4 setup and calibration functions are configured through a pushbutton sequence, as explained in “Setting up the Instrument” and “Calibration” chapters. Two levels of access are provided for setting up and calibrating - level 1 (simple pushbutton sequence) allows access to commonly set up functions, level 2 (power up sequence plus pushbutton sequence) allows access to calibration parameters (see “Calibration” chapter for description). Note; certain functions relating to the optional retransmission output limits are only displayed when the retransmission option is fitted. Changes to the setpoints and other functions are made by pressing the ▲ and ▼ pushbuttons. Below is a brief description of each function.

Set up functions (see also chapter titled “Setting up the Instrument”).

To enter the set up mode, a simple pushbutton sequence is necessary (this prevents accidental alteration of settings). First press the **F** button and then (within 2 seconds) press both the ▲ and ▼ pushbuttons simultaneously. The display will now read **FUNC** thereby indicating that you have entered the Setup Function Mode. Each function may be accessed by pressing the **F** pushbutton to step through the functions as indicated below. Note; The **P** button (only on models with 4 x front panel pushbuttons) may be used to exit the function mode at any time and will abort the function currently displayed without accepting any changes to that function. This is useful for quickly exiting the function mode and as a means preventing accidental or unwanted changes to the functions.

A 1Lo (alarm 1 low setpoint).

Displays and sets the alarm 1 low setpoint value. The low alarm setpoint may be disabled by pressing the ▲ and ▼ pushbuttons simultaneously. When the alarm is disabled the display will indicate **OFF**. Use ▲ or ▼ to adjust the setpoint value if required. Alarm 1 will trip when the displayed value is lower than the **A 1Lo** setpoint value.





A 1Hi (alarm 1 high setpoint).

Displays and sets the alarm 1 high setpoint value. The high alarm setpoint may be disabled by pressing the ▲ and ▼ pushbuttons simultaneously. When the alarm is disabled the display will indicate **OFF**. Use ▲ or ▼ to adjust the setpoint value if required. Alarm 1 will trip when the displayed value is higher than the **A 1Hi** setpoint value.



A 2Lo (alarm 2 low setpoint).

Displays and sets the alarm 2 low setpoint value. The low alarm setpoint may be disabled by pressing the ▲ and ▼ pushbuttons simultaneously. When the alarm is disabled the display will indicate **OFF**. Use ▲ or ▼ to adjust the setpoint value if required. Alarm 2 will trip when the displayed value is lower than the **A 2Lo** setpoint value.

A2H, (alarm 2 high setpoint).

Displays and sets the alarm 2 high setpoint value. The high alarm setpoint may be disabled by pressing the  and  pushbuttons simultaneously. When the alarm is disabled the display will indicate **OFF**. Use  or  to adjust the setpoint value if required. Alarm 2 will trip when the displayed value is higher than the **A2H**, setpoint value.



A1HY (alarm 1 hysteresis [deadband]).

Displays and sets the alarm 1 hysteresis limit and is common for both high and low setpoint values. In the high alarm mode once the alarm is tripped the input must fall below the setpoint value minus the hysteresis value to reset the alarm. In the low alarm mode once the alarm is tripped the input must rise above the setpoint value plus the hysteresis value to reset the alarm. The hysteresis units are expressed in displayed engineering units. Use  or  to adjust the value if required.

A2HY (alarm 2 hysteresis [deadband])

Displays and sets the alarm 2 hysteresis limit (other details as per **A1HY**).



A1TT (alarm 1 trip time).

Displays and sets the alarm 1 trip time and is common for both alarm 1 high and low setpoint values. The trip time is the delay before the alarm will trip. The alarm condition must be present continuously for the trip time period before the alarm will trip. This function is useful for preventing an alarm trip due to short non critical deviations from setpoint. Use  or  to adjust the trip time if required. The trip time is selectable over 0 to 60 seconds.



A2TT (alarm 2 trip time).

Displays and sets the alarm 2 trip time (other details as per **A1TT**).



A1n.o or **A1n.c** (alarm 1 normally open or normally closed)

Displays and sets the alarm relay 1 action to normally open (de-energised) or normally closed (energised), when no alarm condition is present. Use  or  to make changes if required.



A2n.o or **A2n.c** (alarm 2 normally open or normally closed)

Displays and sets the alarm relay 2 action to normally open (de-energised) or normally closed (energised), when no alarm condition is present. Use  or  to make changes if required.

BAR_L (bar graph display low value).

Displays and sets the bar graph low value i.e. the digital display value at which the bar graph will start to operate. May be independently set anywhere within the display range of the instrument. Use  or  to set the low bar graph value.

BAR_H (bar graph high value).

Displays and sets the bar graph high value i.e. the digital display value at which the bar graph will reach its maximum. May be independently set anywhere within the display range of the instrument. Use  or  to set the high bar graph value.

FEE- (recorder/retransmission output low value)

Displays and sets the analog retransmission (4 to 20mA, 0-1V or 0-10V) output low value (4mA or 0V) in displayed engineering units i.e. the digital display value at which 4mA will be retransmitted. Use ▲ or ▼ to set the value if required.

FEE+ (recorder/retransmission output high value).

Displays and sets the analog retransmission (4 to 20mA, 0-1V or 0-10V) output high value (20mA, 1V or 10V) in displayed engineering units i.e. the digital display value at which 20mA will be retransmitted. Use ▲ or ▼ to set the value if required.

dFnd (display rounding).

Displays and sets the display rounding value. This value may be set to 0 - 5000 displayed units. Display rounding is useful for reducing the instrument resolution without loss of accuracy, in applications where it is undesirable to display to a fine tolerance. (example if set to 10 the instrument will display in multiples of 10).

dCPt (decimal point selection).

Displays and sets the decimal point. By pressing the ▲ or ▼ pushbuttons the decimal point position may be set. The display will indicate as follows: 0 (no decimal point), 0.1 (1 decimal place), 0.02 (2 decimal places), 0.003 (3 decimal places).

FtF (digital filter)

Displays and sets the digital filter value. Digital filtering is used for reducing susceptibility to short term interference. The digital filter range is selectable from 0 to 8, where 0 = none and 8 = most filtering. A typical value for the digital filter would be 3. Use ▲ or ▼ to alter if required.

SPFn (special function)

Displays and sets the special function input selection (see chapter on Remote Input Functions) . May be set to any one of the following: none **NONE**, peak hold **PH: d**, display hold **dH: d**, peak memory **H**, valley memory **Lo**, no program access **no.AC**, setpoint only access **SP.AC** or pushbutton tare **tARE**. The selected special function is actuated by a remote contact closure between the terminals 7 (ext in) and 8 (gnd).

Calibration functions (see also chapter titled “Calibration”).

To enter this mode a special “power up procedure must be followed” this procedure prevents accidental alteration of calibration and provides a degree of calibration security.

First, turn off the instrument power.

Press and hold the **F** button whilst applying power to the instrument. The instrument will momentarily show **CAL** in the wake up message to let you know that the calibration level of the function mode is now accessible.

To enter into the calibration mode, you must now enter the function set up

mode as described earlier in this chapter “set up functions” and step through the functions until the display indicates **CAL 1**.

CAL 1 & CAL 2 (calibration by applying an input signal)

Displays and sets the two independent calibration/scaling points of the input to the display. See “Calibration” chapter for full details of setting up. Enter **CAL 1** input value, **SCAL 1** scaling/displayed value, then enter **CAL 2** input value and **SCAL 2** scaling/displayed value. The calibration of these points may also be carried out as independent operations.

OFFSE (offset calibration)

Allows the instrument calibration to be offset by a single point value. This value is added or subtracted across equally the range of the instrument.

UCAL (uncalibration).

Used to set the instrument back to the factory calibration values. This function should only be used when calibration problems exist, and it is necessary to clear the calibration memory. See “Calibration” chapter for a full description.

Returning to normal measure mode

When the calibration has been completed it is advisable to return the instrument to the normal mode (where calibration functions cannot be tampered with). To return to normal mode, turn off power to the instrument, wait a few seconds and then restore power.

8 Setting up the Instrument

Setting up and calibrating the PM4 is extremely easy, since most functions are changed or viewed by pressing the pushbuttons. The instruments may have rear accessible pushbuttons, some versions also have front panel keypads which perform the same functions. Note: some initial configuring may require dismantling the instrument to alter selection links (see sections on hardware configuration).

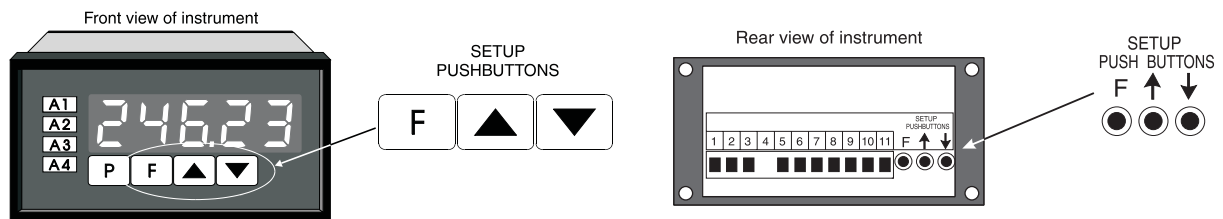

8.1 Step 1 - Entering the Function Setup Mode

To enter the setup mode a simple pushbutton sequence is necessary (this prevents accidental alteration of settings). First press, then release, the **F** button and then (within 2 seconds) press, then release, both the **▲** and **▼** buttons simultaneously. The display will now read **FUNC** indicating that you have entered the Function Setup Mode.

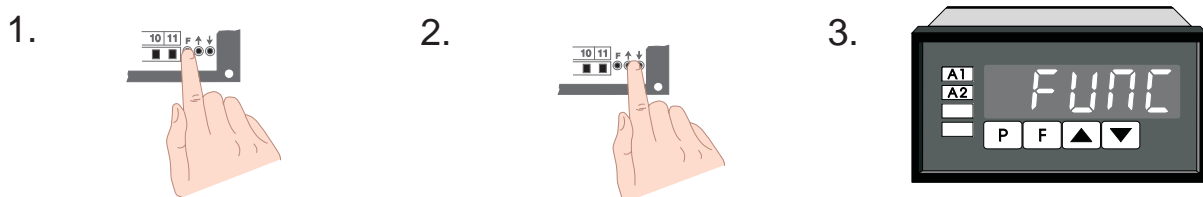



8.2 Step 2 - Stepping through the settings

The display of **FUNC** is followed by the first setup message **A 1 L o** (Alarm 1 Low setting). As with all other messages the first display lets you know which parameter will be affected when changes are made. Each time the **F** button is pressed and released another setup parameter is displayed (see "Function Table" for list of functions). After the last function the display returns to the normal process display.

8.3 Step 3 - Making changes to the settings

Whilst still in the Function Setup Mode, press the **F** button until you reach the parameter you wish to change. Initially the display will indicate the particular function (e.g. **A 1 L o**), this will be followed by a display showing the current status of that setting (e.g. **50.0**). The setting may now be changed by pressing the **▲** or **▼** pushbutton until the desired value is displayed. You may then proceed through the functions until you reach the next function that you wish to change or until you exit the function mode.

Note 1: Remember the alarm relays may be configured to have **both** a high and a low setting. If the relay is required to trip at **only one point** (e.g. **AlH**, high alarm only) turn off the unwanted setpoint by selecting the unwanted setting (e.g. **AlLo**) and press the  and  pushbuttons simultaneously. The display will now indicate **OFF** confirming that Alarm Relay 1 will only trip when the display value is higher than the setpoint value.

Note 2: Instruments with front panel pushbuttons have an additional button (**P** button). Pressing this button in the setup or calibrate mode exits the current function leaving it unchanged. This is useful for aborting a current function or a method of quickly exiting the function mode by stepping to the next function and then pressing the **P** button.

9 Remote Input Functions

The PM4 remote input allows the operation of a special function via a voltage free contact to the instrument terminal block (terminals 7 and 8). The input is either a bi-state contact closure (toggle switch, PLC or other external switch) or a momentary pushbutton contact. The instrument may be configured to perform any **one** of the following functions:

- None
- Peak Hold
- Display Hold
- Peak Memory (Max)
- Valley Memory (Min)
- No Program access
- Setpoint Access Only
- Pushbutton Tare

None (None)

This function is selected when none of the special functions are required. If a remote pushbutton is used with this function selected, the button behaves in the same way as the **P** button which is used with some front panel pushbutton versions (used to toggle display between temperature and pH on PM4-PH instruments for example).

PHLD (Peak Hold)

This function displays and holds the peak reading, when the contact input is closed. When the contact is open the display indicates the live reading.

dHLD (Display Hold)

The display hold function is similar to peak hold, except that the held reading is the value displayed when the switch contact is closed.

H (Peak Memory)

The peak memory (max) is displayed when the pushbutton contact is closed momentarily, the value displayed is the maximum input value recorded since the memory was last reset. The display is returned to the normal display after 20 seconds (note: for instruments with a front panel **P** button only, pressing **P** button returns display to normal). To reset the peak memory the button must be held closed for 1 to 2 seconds.

L (Valley Memory)

The valley memory (min) operates in a similar way to the peak memory.



no.PC (No Program Access)

Inhibits access to functions via pushbuttons and front panel keypads. The remote input requires a contact closure to allow access to functions. The switch input for this function is usually a keyswitch or wire link.

SP.AC (Setpoint Access Only)

Allows access to alarm setpoints only when keyswitch is open. Allows full access with the keyswitch closed. The switch input for this function is usually a keyswitch or wire link.

Selecting the remote input function

To select the required function, enter the setup mode in the usual way (see “Setting up the instrument”) and step through the functions until you reach the display message **SPFN** (special function). Use the  and  buttons select the required function.

Effect of special functions on relays, bar graph and retransmission.

The effect of the remote input function on the alarms, retransmission output and bar graph (when fitted) is programmable. You may for example require the retransmission output to follow the peak hold display instead of following the actual input. A function to select the effect on the alarms, retransmission and bar graph is provided. The following selections will appear after **SPFN** only when the instrument is set to the **CAL** (calibration mode). For details on entering the calibration mode see the chapter on calibration.

AL 1 (Alarm 1)

Select **LI UE** or **SPFN** (display or special function). **LI UE** selects the live input as the value to trigger the alarm 1. **SPFN** selects the special function value (peak, display hold, tare etc.) as the value used to trigger alarm 1.

AL 2 (Alarm 2)

as above but affects alarm 2.

BAR (Bar Graph)

as above but affects bar graph.

REC (Recorder (retransmission))

as above but affects the analog retransmission.

RS232 (RS232 (retransmission))

as above but affects the RS232 retransmission (when fitted).

These functions will not appear if **NONE** is selected as the special function.

With functions requiring a latching switch (peak hold and display hold) the **SPFN** value will be used when the switch is ON and the display value when the switch is OFF.

10 Calibration

To enter the calibration mode a special “power up procedure” must be followed. This procedure prevents accidental alteration of calibration and provides a degree of calibration security.

The calibration procedure allows for two calibration points to be independently set. This is useful where the calibration is being carried out on site and delays are experienced during the calibration procedure (i.e., filling tanks etc.).

Preparing to initialise

Turn off instrument Power.

Initialising the calibration mode

Press and hold the **F** button whilst applying power to the instrument. The instrument will momentarily show **CAL** (during the wake up messages) to let you know that the calibration level of the function mode is now accessible.

Entering the calibration mode

To enter the calibration mode, you must enter the function set up mode by pressing, then releasing **F** then, within 2 seconds, pressing, then releasing, **▲** and **▼** simultaneously. Step through the functions by pressing and releasing **F**, until the display indicates **CAL 1**.

Note: as you step through the functions take care not to accidentally alter the settings of the various functions.

Calibration (by applying an input signal)

Now press the **▲** and **▼** buttons simultaneously to enter the calibration mode. The display will now flash **CAL 1** (1st calibration point) every few seconds followed by the “live” reading. ***Apply a known input to the instrument of nominally 0% (this value is not critical and may be anywhere within the measuring range of the instrument).** When the reading has stabilised press the **F** button. The display will indicate **SEL 1** (scale 1) followed by the scale value in memory. Now press the **▲** or **▼** button to obtain the required scale (calibration) value. Press the **F** button the display will now indicate **CAL End** (indicating that calibration of the first point

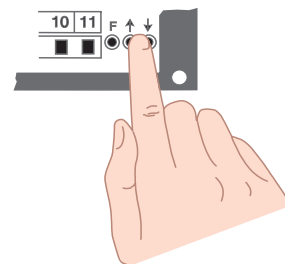

is complete). The display will now indicate **CAL 2** (2nd calibration point). Either step through the functions using the **F** button (to bypass the second calibration point) or enter the 2nd calibration mode as above by pressing the **▲** and **▼** buttons simultaneously. Apply an input of 100% (again this value is not critical, for best accuracy should not be too close to the previous value). When the reading has stabilised, press the **F** button, the display will now read **SCL 2** (scale 2) followed by the second scale value in memory. Press the **▲** or **▼** button to obtain the required scale value. Press the **F** button the display will now read **CAL End** (indicating that calibration of the second point is complete). The display will return to the measure mode (with calibration access). Note: When entering the second point independently, the first calibration point may be bypassed, simply by pressing the **F** button instead of the **▲** and **▼** buttons simultaneously.

Offset Calibration

Sometimes it is necessary to make a single point adjustment to the calibration, it may be done using this function. Note the value set in this function will add or subtract the value equally across the measurement range of the instrument.

Enter the calibration mode as described above, but do not enter **CAL 1** or **CAL 2** setup functions. Step through the functions until the display indicates **OFFSt**, Now press the **▲** and **▼** buttons simultaneously to enter the offset mode. The display will now indicate **OFFSt** (offset) followed by the “live” reading. *Apply a known input to the instrument. When the reading has stabilised press the **F** button. The display will indicate **SCL E** (scale) followed by the value set in memory. Now press the **▲** or **▼** button to obtain the required offset. Press the **F** button the display will now indicate **OFFSt End** (indicating that the offset calibration is complete). The display will return to the measure mode (with calibration access).

Uncalibration

The uncalibration function sets the instrument back to the factory calibration value. This function is useful as a temporary measure when the input source device/transmitter is replaced and on the spot recalibration is difficult or when a calibrating error exists due to a problem during calibration. The uncalibration mode follows the calibration mode described above and is initialised by pressing the **▲** and **▼** buttons simultaneously (note this function will delete the existing calibration and should only be used when necessary). The display will show **CAL Cl F** indicating that the calibration is cleared. The display will return to the measure mode (with calibration access).

Returning to the normal measure mode

Turn off power to the instrument (to exit the calibration access mode), wait a few seconds and then restore power.

Note:

* “Apply a known input” refers to either a simulated or real input. Since the PM4 is intended for use with various transducers, the input may take the form of a weight (weighing applications), an air or hydraulic pressure input (pressure transducers), temperature (temperature transmitters with 4 to 20 mA outputs) or a suitable electronic simulator etc.

11 Input/Output Configuration

If you need to alter the input or output configuration proceed as follows:

1. Remove the plug in terminals from the rear of the instrument

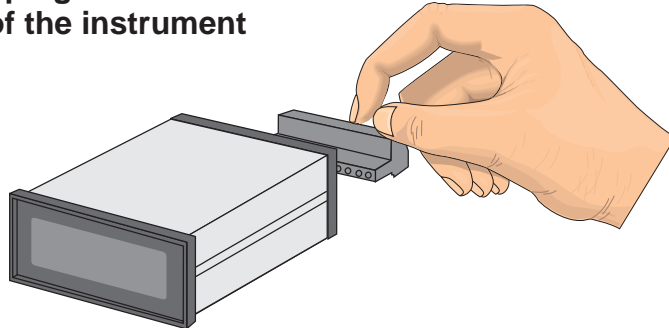

2. Remove 4 x self tapping screws from back cover, remove back cover by pulling it away from the instrument

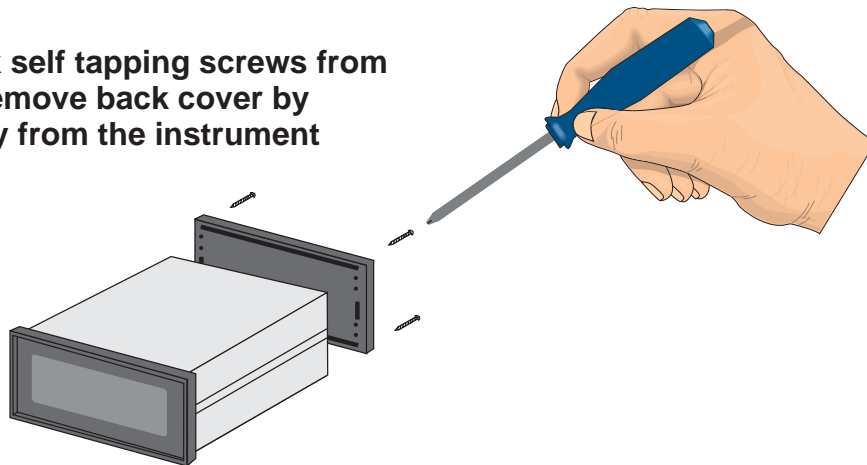

3. Using a screwdriver, loosen the earth screw which passes through the PCB then slide out the board or boards

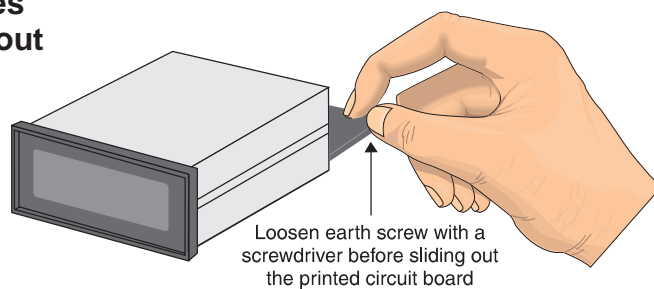

4. Configure the PCB links as required, see appropriate chapter
5. Slide PCB back into the case
6. Re tighten the earth screw which passes through the PCB
7. Refit back cover and fix with the self tapping screws
8. Plug the terminal strips back into the rear of the instrument

12 Hardware Configuration

12.1 Selecting the Input Range

Dismantle the instrument as described in section titled “Input/Output Configuration”. Insert the links in the appropriate location on the pin header, to suit the range required.

LINK description	INPUT (END TO END RESISTANCE)			
	3 WIRE 100Ω to 1MΩ	2 WIRE 100Ω to 1KΩ	2 WIRE 1KΩ to 10KΩ	2 WIRE 10KΩ to 100KΩ
10K	NIL	NIL	IN	NIL
1K	NIL	IN	NIL	NIL
2 WIRE	NIL	IN	IN	IN

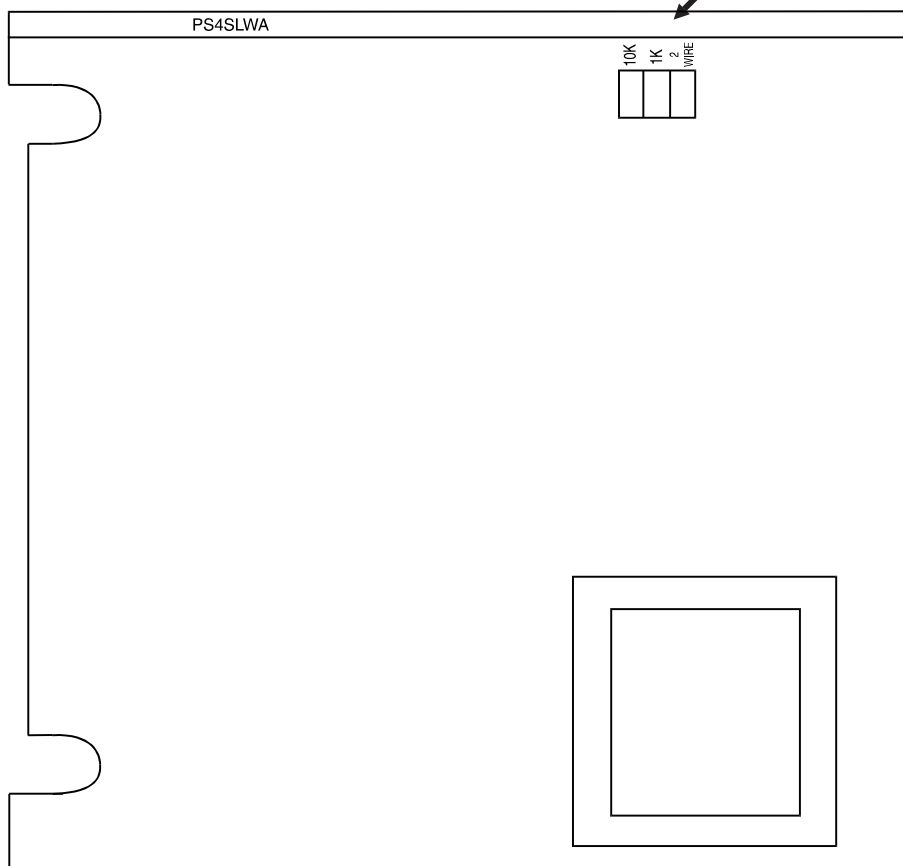

Main Circuit Board

14 Configuring the output board

The optional output board is factory supplied with the necessary components for the output options required. Combinations of three output types are available:

- a/ Second relay output
- b/ Isolated analog retransmission (4-20mA, 0-1V or 0-10V)
- c/ Isolated DC Voltage output (to power transmitters etc)

PCB links are fitted to the circuit board to provide data to the microprocessor and to connect the electronic components for the correct output types. It may be necessary to alter the PCB links to change the analog output or DC voltage output (see link settings below), see the chapter entitled "Input/output configuration" for details on dismantling the instrument.

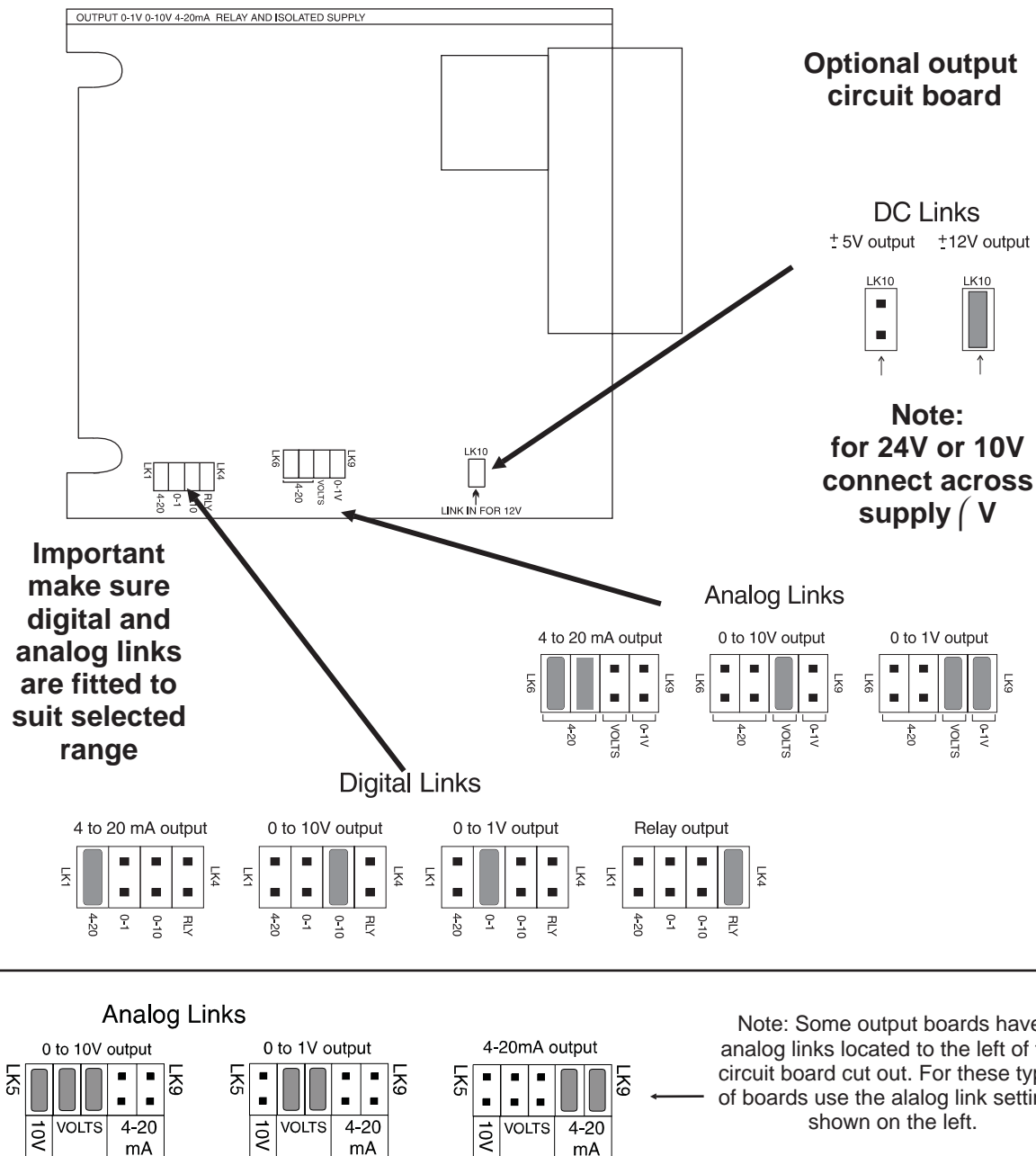

15 Specifications

15.1 Technical Specifications

Resistance range:	3 wire 100Ω to 1MΩ (end to end) or 2 wire 100Ω to 100KΩ
ADC Resolution:	1 in 20,000
Accuracy:	0.05% of FS when calibrated
Sample Rate:	4 per sec
Conversion Method:	Dual Slope ADC
Microprocessor:	MC68HC05C8 CMOS
Ambient Temperature:	LED -40 to 60°C, LCD -10 to 50°C
Humidity:	5 to 95% non condensing
Display:	LED Models 4 digit 20mm, 5 digit 14.2mm + status LEDs + 4 way keypad. 6 digit 14.2mm + 4 way keypad LED Bar Graph 20 segment bar + 4 digit 7.6mm LCD Models 4 digit 12.7mm, 4½ digit 10.2mm
Power Supply:	AC 240V, 110V or 24V 50/60Hz DC 9 to 55V
Power Consumption:	AC supply 4 VA max, DC supply, consult AIC (depends on display type & options)
Output (standard):	1 x relay, Form, A rated 5A resistive
Relay Action:	Programmable N.O. or N.C.

15.2 Output Options

2nd Relay:	Same specs as Relay 1
Analog Retransmission:	4 to 20mA standard 0 to 1V and 0 to 10V link selectable
Serial Communications:	(not released)
DC Voltage Output:	Isolated ±12V(24V) standard, ±5V(10V) link selectable.

15.3 Physical Characteristics

Bezel Size:	DIN 48mm x 96mm x 10mm
Case Size:	44mm x 91mm x 120mm behind face of panel
Panel Cut Out:	45mm x 92mm +1mm &- 0mm
Connections:	Plug in screw terminals (max 1.5mm wire)
Weight:	400 gms Basic model, 450 gms with option card

Guarantee and Service

Products manufactured by Amalgamated Instrument Co Pty Ltd are guaranteed against faulty workmanship for a period of 2 years from the date of dispatch.

Our obligation assumed under this guarantee is limited to the replacement of parts which, by our examination are proved to be defective and have not been misused, carelessly handled, defaced, damaged due to excessive installation. This guarantee is VOID where the unit has been opened, tampered with or if repairs have been made or attempted by anyone except an authorised representative of Amalgamated Instrument Co Pty Ltd.

Products for attention under guarantee (unless otherwise agreed) **must be returned to the factory freight paid** and, if accepted for free repair, will be returned to the customers address in Australia free of charge.

When returning the product for service or repair, a full description of the fault must be given, and the mode of operation used when the product failed.

In any event Amalgamated Instrument Co Pty Ltd has no other obligation or liability beyond replacement or repair of this product.

A.I.C. may make such modifications to any existing or future models of the unit as it may deem necessary without incurring any obligation to incorporate such modifications in units previously sold or to which this guarantee may relate.

If service other than under guarantee is required please contact Amalgamated Instrument Co Pty Ltd directly.