

**Model PM4-SSI
Synchronous Serial Interface
Panel Mount Display/Controller
Operation and Instruction Manual**

AMALGAMATED INSTRUMENT CO PTY LTD

ACN: 001 589 439

*Unit 5, 28 Leighton Place Hornsby
NSW 2077 Australia*

*Telephone: +61 2 9476 2244
Facsimile: +61 2 9476 2902*

*e-mail: sales@aicpl.com.au
Internet: www.aicpl.com.au*

Table of Contents

1	Introduction	3
2	Mechanical Installation	4
3	Electrical installation	5
4	Function tables - summary of setup functions	8
5	Explanation of functions	12
6	BCD Converter Input Functions	33
7	Specifications	35
8	Guarantee and service	36

1 Introduction

This manual contains information for the installation and operation of the PM4-SSI monitor. The input to this instrument is a Synchronous Serial Interface (SSI) up to 31 bits of binary or Gray code, user selectable. The SSI data transmission is initiated by clock pulses generated by the PM4 monitor. Typical SSI output devices include absolute position encoders and distance measuring equipment. Data transmission distances of up to 1.2km are possible when using SSI data communications.

The display can be scaled in engineering units e.g. "mm" by one of three methods:

1. By entering values at the **INPT** and **SCALE** functions, These values work together with the output value from the encoder in a formula used to calculate the required display scaling. See functions 5.28 and 5.29.
2. By the **USCL** method which allows the encoder to be zeroed or assigned a preset value in one position then moved to a known position and its value for this position entered (see **USCL** function 5.33). The ability to use external switch with front **P** and **F** buttons makes this method most useful where the scaling is to be changed frequently.
3. By entering the values required at two known points (see **USER SCALE** function 5.37). This method also allows the use of a calibration offset.

The PM4-SSI may also be used with models RM-BC and RM4-BC BCD to SSI converters. When used with one of these converters a BCD input is converted to an SSI output which is then interpreted by the PM4-SSI. The **SET OPER** setup function is used to select the input type required. If the input from a general SSI output device then select SSI at this function. If the input is from model RM-BC or RM4-BC then there is a choice of either 8 bit BCD (**bc 8**) or 24 bit BCD (**bc 24**). Refer to Chapter 6 for a description of functions seen when in the **bc 8** or **bc 24** modes.

Scaling and setup of the PM4 monitor are all accomplished by push button operation. "On screen" prompts are given for each function to assist in setting up the instrument. Some changes may require dismantling the instrument to alter PCB links.

An inbuilt relay provides an alarm/control function, optional relays (giving up to 7 in total), optically isolated analog or digital re-transmission (including scaled pulse re-transmission) and excitation voltage may also be provided.

Unless otherwise specified at the time of order, your PM4 has been factory set to a standard configuration, see the function table for your selected mode for default settings.

Full electrical isolation between power supply, input voltage and re-transmission output is provided by the PM4, thereby eliminating grounding and common voltage problems. This isolation feature makes the PM4 ideal for interfacing to computers, PLCs and other data acquisition devices.

The PM4 series of Panel Mount Monitors are designed for high reliability in industrial applications. The high brightness LED display provides good visibility, even in areas with high ambient light levels.

2 Mechanical Installation

Choose a mounting position as far away as possible from sources of electrical noise such as motors, generators, fluorescent lights, high voltage cables/bus bars etc. An IP65 access cover which may be installed on the panel and surrounds is available as an option to be used when mounting the instrument in damp/dusty positions. A wall mount case is available, as an option, for situations in which panel mounting is either not available or not appropriate. A portable carry case is also available, as an option, for panel mount instruments.

Prepare a panel cut out of 45mm x 92mm +1 mm / - 0 mm (see diagram below). Insert the instrument into the cut out from the front of the panel. From the rear of the instrument fit the two mounting brackets into the recess provided (see diagram below). Whilst holding the bracket in place, tighten the securing screws being careful not to over-tighten, as this may damage the instrument. Hint: use the elastic band provided to hold the mounting bracket in place whilst tightening securing screws.

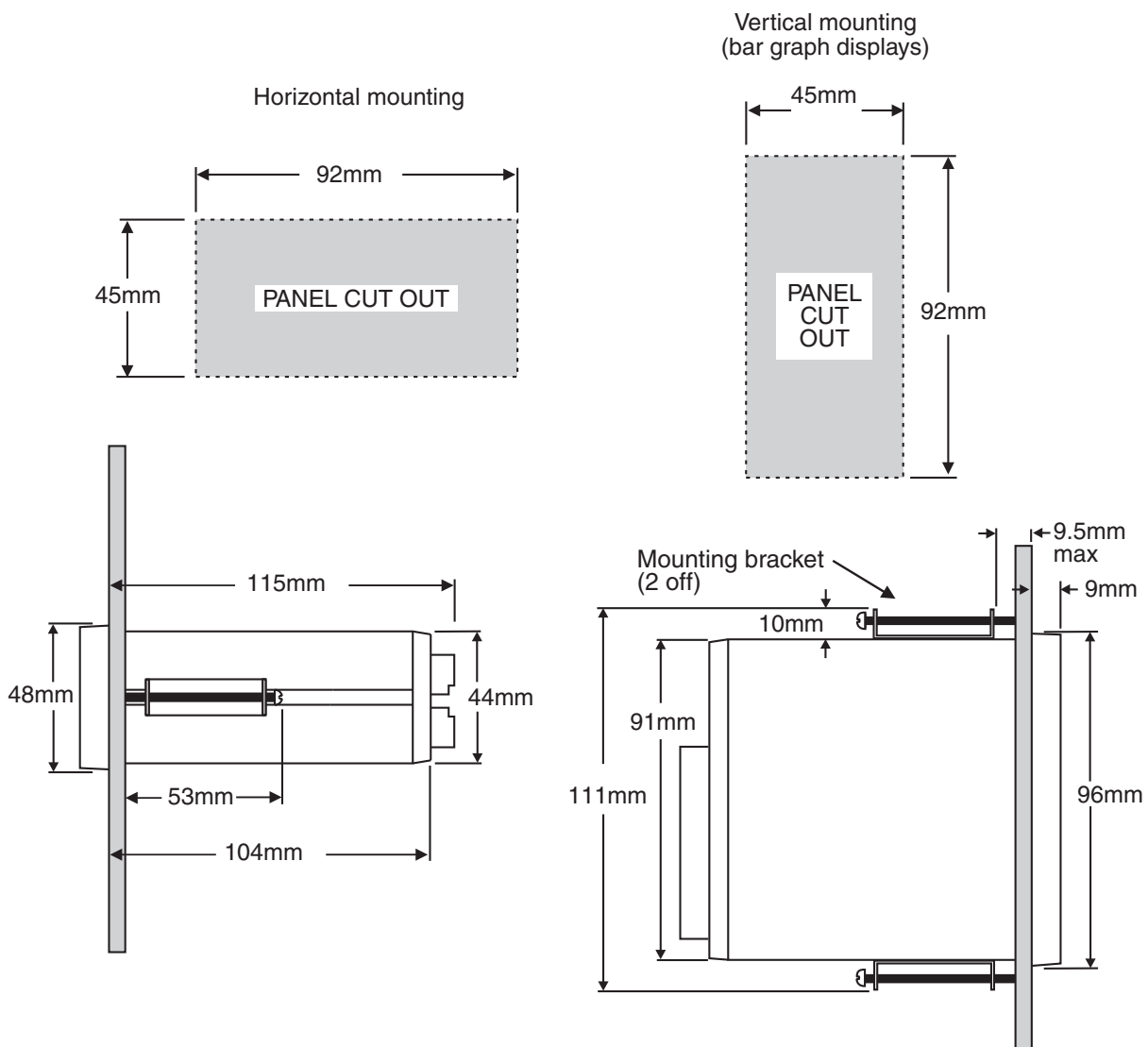

3 Electrical installation

3.1 Electrical installation

The PM4 Panel Meter is designed for continuous operation and no power switch is fitted to the unit. It is recommended that an external switch and fuse be provided to allow the unit to be removed for servicing.

The plug in, screw type, terminal blocks allow for wires of up to 2.5mm² to be fitted. Connect the wires to the appropriate terminals as indicated below. Refer to connection details provided in this chapter to confirm proper selection of voltage, polarity and input type before applying power to the instrument.

When power is applied the instrument will cycle through a display sequence indicating the software version and other status information, this indicates that the instrument is functioning. Acknowledgement of correct operation may be obtained by applying an appropriate input to the instrument and observing the reading. The use of screened cable is recommended for signal inputs.

For connection details of optional outputs refer to the separate "PM4 Panel Meter Optional Output Addendum" booklet supplied when options are fitted.

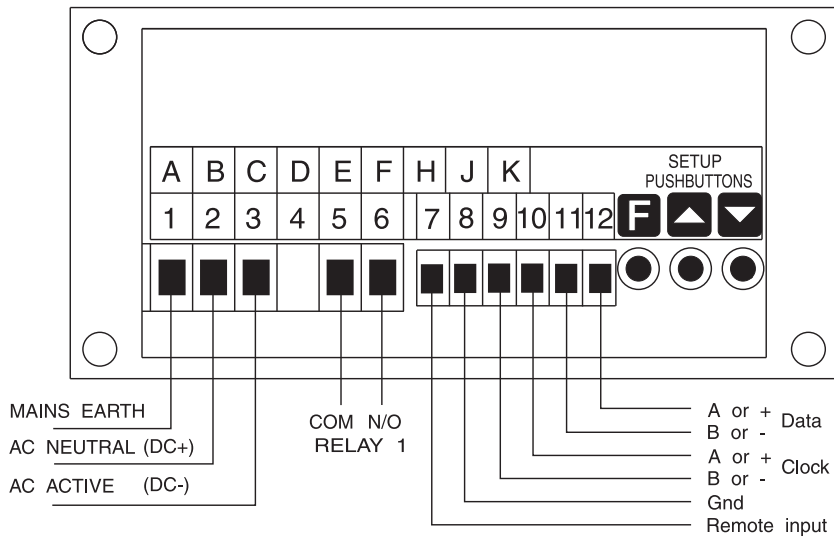

 N1440	
1	MAINS EARTH
2	240 VAC NEUTRAL
3	240 VAC ACTIVE
5	RELAY 1 COM
6	RELAY 1 N/O
7	REMOTE INPUT
8	GROUND
9	CLOCK B
10	CLOCK A
11	DATA B
12	DATA A
PM4-SSI-240-5E	
SERIAL No.: XXXX-XXX	

3.2 Electrical connection examples

If output options are fitted refer to the "PM4 Panel Meter Optional Output Addendum" booklet for connection details.

AC power connections - supply type is factory configured, check before connecting

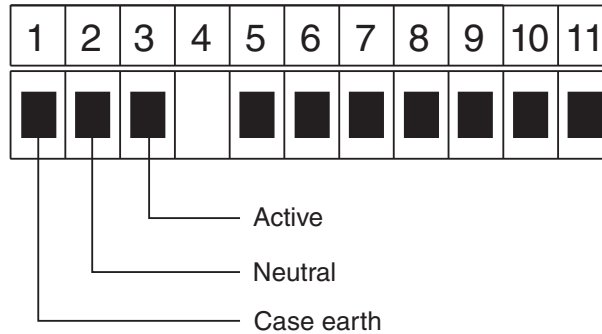

DC power connections (12 to 48VDC) - supply type is factory configured, check before connecting

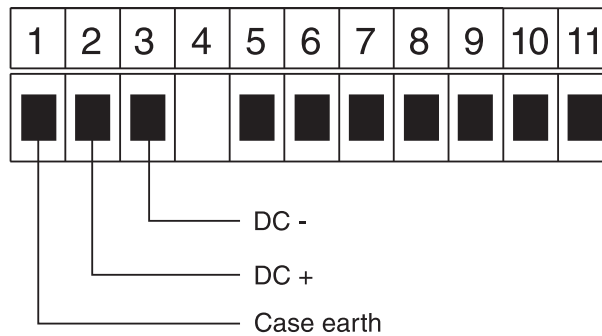

Clock and signal connections between sensor and display

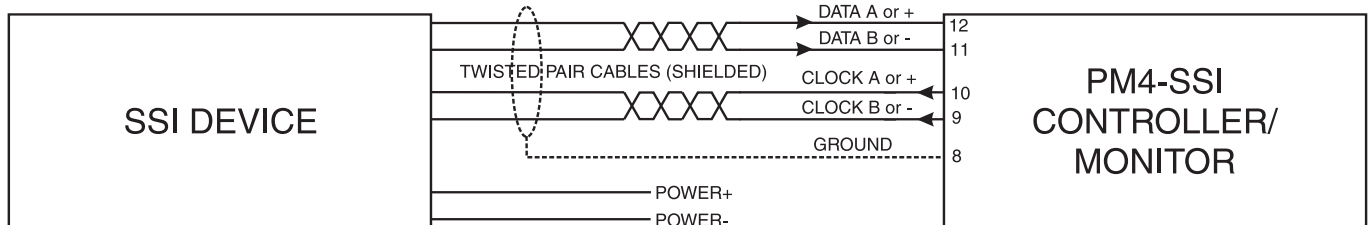

Maximum cable length: Maximum cable length is normally determined by the device being connected to the PM4. Consult the handbook for the SSI device used for details of maximum cable length. Notes: Twisted pair cable must be used for clock and data. refer to the **SSI RATE** function for details of clock frequency settings which may be required for long cable lengths and to the section on link settings below.

3.3 Input Board Link Settings

Two links are fitted to the input board, these are LK1 and LK2. These links are used to bring terminating resistors for the clock and data lines into or out of circuit. For long cable runs these links should be in. The links are located close to the DATA A and B connector on the input circuit board.

3.4 Input Output Configuration

If you need to alter the input or output configuration link settings proceed as follows:

1. Remove the plug in terminals from the rear of the instrument

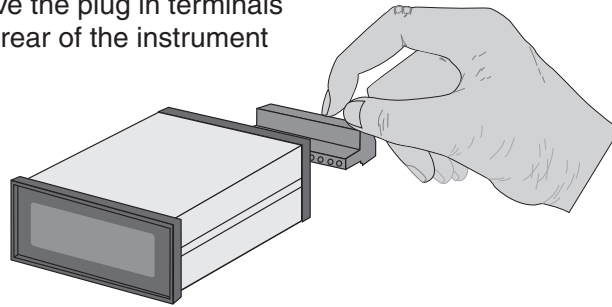

2. Remove the 4 x self tapping screws from the back cover then remove the back cover by pulling it away from the instrument

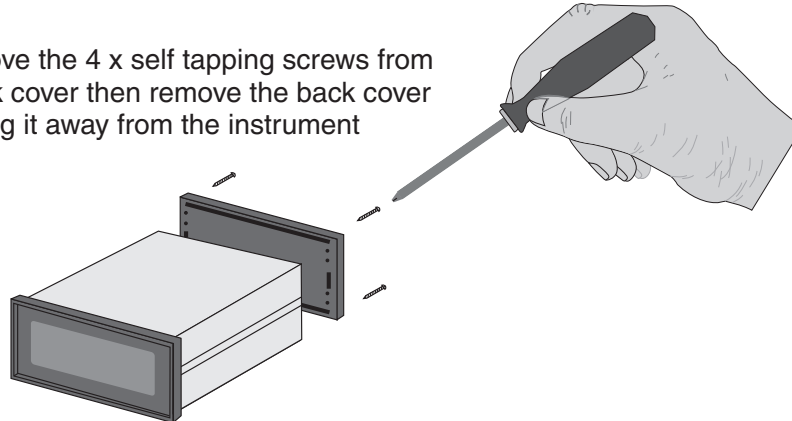

3. Remove the earth screw which passes through the underside of the case then slide out the board or boards

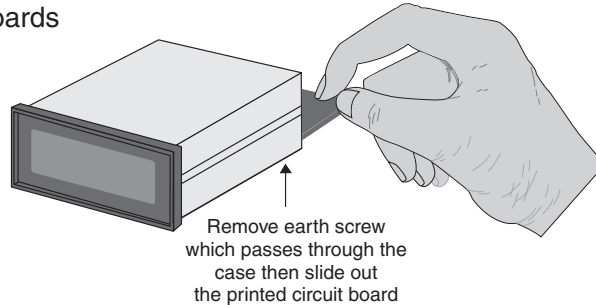

4. Configure the PCB links as required, see appropriate chapter
5. Slide PCB back into case
6. Replace the earth screw which passes through the case
7. Refit the back cover and fix with the self tapping screws
8. Plug the terminal strips back into the rear of the instrument

4 Function tables - summary of setup functions

Note: the order in which the functions appear on the display may not be exactly as shown below. The availability and order of functions is determined by choice of function settings and options fitted.

Functions in this first table are available in **FUNC** or **CAL** mode

Display	Function	Range	Default	Your record	Ref/Page
AxLo	Low setpoint value for designated alarm relay <i>x</i>	Any display value or OFF	OFF	See 4.1	5.1 / 14
AxHi	High setpoint value for designated alarm relay <i>x</i>	Any display value or OFF	OFF	See 4.1	5.2 / 14
AxHY	Hysteresis value for the designated alarm relay <i>x</i> .	0 to 9999	10	See 4.1	5.3 / 15
AxTt	Trip time delay for the designated alarm relay <i>x</i> .	0 to 9999	0	See 4.1	5.4 / 15
Axrt	Reset time delay for the designated alarm relay <i>x</i> .	0 to 9999	0	See 4.1	5.5 / 16
Axn.o or Axn.c	Alarm relay <i>x</i> action to normally open (de-energised) or normally closed (energised)	Axn.o or Axn.c	Axn.o	See 4.1	5.6 / 16
AxSP or Axt 1 etc.	Relay operation independent setpoint or trailing setpoint (*Optional)	AxSP or Axt 1 etc.	AxSP	See 4.1	5.7 / 16
P.SET	Preset value	Any display value	0		5.8 / 17
brgt	Display brightness level	1 to 15	15		5.9 / 17
dull	Display remote brightness switching	0 to 15	1		5.10 / 17
bAr -	Bargraph low value (seen only on bargraph display instruments)	Any display value	0		5.11 / 18
bAr ~	Bargraph high value (seen only on bargraph display instruments)	Any display value	1000		5.12 / 18

(*Optional)—this function will only be accessible if the relevant option is fitted

Functions in this second table are available only in **CAL** mode or if **ACCS** is set to **ALL**

Display	Function	Range	Default	Your record	Ref/Page
bAr tYPE	Bargraph type for instruments with bargraph display (seen only on bargraph display instruments)	bAr , 5.dot , d.dot , C.bAr or r.dot	bAr		5.13 / 18
d9OP	Digital output option mode (*Optional)	bcd , b.SCL , b, n or b, n2	b, n2		5.14 / 19
d9.OP	Digital output option polarity (*Optional)	RI 0 or RI,	RI 0		5.15 / 20
bcd StAr	Digital output option BCD start position (*Optional)	0 , 1 or 2	0		5.16 / 20
d, 9-	Digital output option low value (*Optional)	Any display value	0		5.17 / 20
d, 9+	Digital output option high value (*Optional)	Any display value	1000		5.18 / 20
FEE-	Analog output option low display value (*Optional)	Any display value	0		5.19 / 21
FEE+	Analog output option high display value (*Optional)	Any display value	1000		5.20 / 21
drnd	Display rounding	1 to 5000	1		5.21 / 21
dCPt	Decimal point	0 , 0.1 etc.	0		5.22 / 22
FLtR	Digital filter	0 to 8	2		5.23 / 22
P.but	P button function	NONE.H. , Lo.H; Lo. ZEFO or P.SET	NONE		5.24 / 22
r, i NP	Remote input (external input)function	NONE. , P.HLd. , d.HLd.H. , Lo.H; Lo. ZEFO. , SP.Ac. , No.Ac.CAL.S .P.SET or dULL	NONE		5.25 / 23
ACCS	Access mode	OFF.EASY. NONE or ALL	OFF		5.26 / 24
SPAC	Setpoint access mode (*Optional)	RI, RI-2 etc.	RI		5.27 / 24
i NPt	Display input scaling factor	1 to any positive display value	1		5.28 / 24

(*Optional)—this function will only be accessible if the relevant option is fitted

SCALE	Display scaling factor	1 to any display value	1		5.29 / 25
SSIBITS	Number of input bits	1 to 31	1		5.30 / 25
SIGN	Sign bit	on or OFF	OFF		5.31 / 26
SSICode	SSI code type	bin or GRAY	bin		5.32 / 26
USCL	User simple scaling method	on or OFF	OFF		5.33 / 26
DISP RATE	Display update rate	1, 2, 4, 8, 16 or 32	4		5.34 / 27
CLRZERO	Clear zero	n/a	n/a		5.35 / 27
CLRUSCL	Clear user scale operation	n/a	n/a		5.36 / 28
USESCALE	Two point live input scaling	on or OFF	OFF		5.37 / 28
CAL1	First live input calibration scaling point	Any display value	n/a		5.38 / 28
CAL2	First live input calibration scaling point	Any display value	n/a		5.39 / 29
CALOFFSET	Calibration offset	Any display value	n/a		5.40 / 29
SETOPER	Set display operation	SSI, bc8 or bc24	SSI		5.41 / 30
SSIRATE	SSI clock frequency	Lo or Hi	Hi		5.42 / 30
BAUDRATE	Baud rate for serial communications (*Optional)	300.600. 1200.2400. 4800.9600. 19.2 or 38.4	9600		5.43 / 30
PRTY	Parity for serial communications (*Optional)	NONE.EVEN or odd	NONE		5.44 / 30
OUTPUT	Output for serial communications (*Optional)	DISP.Cont. POLL, R.buS or n.buS	Cont		5.45 / 31
ADDR	Instrument address for serial communications (*Optional)	0 to 31	0		5.46 / 31

(*Optional)—this function will only be accessible if the relevant option is fitted

4.1 Relay table

Record your relay settings in the table below

Display	Relay 1	Relay 2	Relay 3	Relay 4	Relay 5	Relay 6	Relay 7
AxLo							
AxH,							
AxHY							
AxLl							
Axrl							
Axn.o or Axn.c							
AxSP or AxLl etc.	n/a						

5 Explanation of functions

The PM4 setup and calibration functions are configured through a push button sequence. The three push buttons located at the rear of the instrument (also at the front on some display options) are used to alter settings. Two basic access modes are available:

FUNC mode (simple push button sequence) allows access to commonly set up functions such as alarm setpoints.

CAL mode (power up sequence plus push button sequence) allows access to all functions including calibration parameters.

Once **CAL** or **FUNC** mode has been entered you can step through the functions, by pressing and releasing the **F** push button, until the required function is reached. Changes to functions are made by pressing the or push button (in some cases both simultaneously) when the required function is reached. See the flow chart example on the following page.

Entering **CAL** Mode



1. Remove power from the instrument. Hold in the **F** button and reapply power. The display will briefly indicate **CAL** as part of the "wake up messages" when the **CAL** message is seen you can release the button. Move to step 2 below.



2. When the "wake up" messages have finished and the display has settled down to its normal reading press, then release the **F** button. Move to step 3 below.

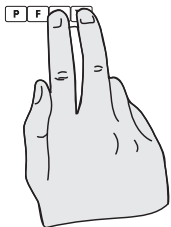

3. Within 2 seconds of releasing the **F** button press, then release the **▲** and **▼** buttons together. The display will now indicate **FUNC** followed by the first function.

Note: If step 1 above has been completed then the instrument will remain in this **CAL** mode state until power is removed. i.e. there is no need to repeat step 1 when accessing function unless power has been removed.

Entering **FUNC** Mode

No special power up procedure is required to enter **FUNC** mode.



1. When the "wake up" messages have finished and the display has settled down to its normal reading press, then release the **F** button.

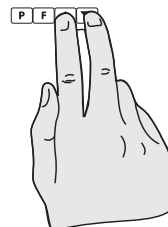

2. Within 2 seconds of releasing the **F** button press, then release the **▲** and **▼** buttons together. The display will now indicate **FUNC** followed by the first function.

Example: Entering **FUNC** mode to change alarm 1 high function **A 1H**, from **OFF** to **100**

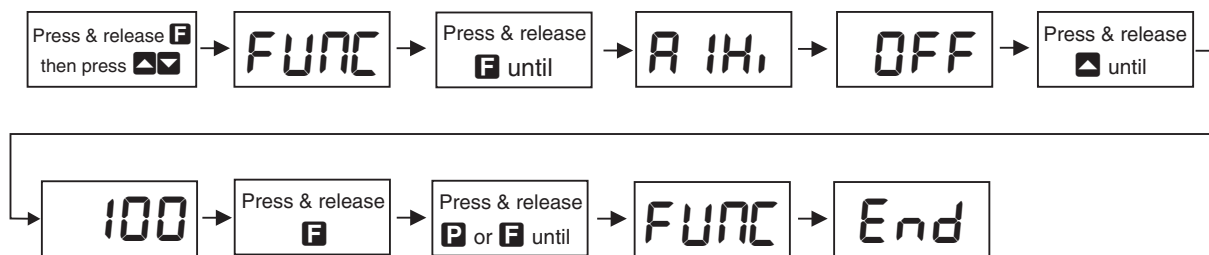

Example: Entering **CAL** mode to change decimal point function **dCPT** from **0** to **0.02**

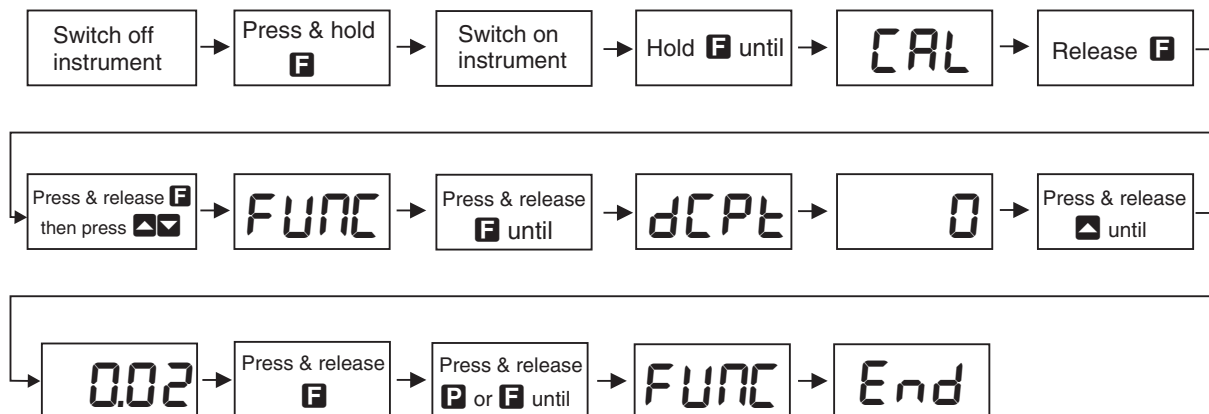

Easy alarm relay adjustment access facility

The display has an easy alarm access facility which allows access to the alarm setpoints simply by pressing the **F** button at the front or rear of the instrument. The first setpoint will then appear and changes to this setpoint may be made to this setpoint via the **▲** or **▼** buttons. Press the **F** button to accept any changes or to move on to the next setpoint. Note: this easy access also functions in the same manner for the PI control setpoint (relay and/or analog PI output) if PI control is available. The instrument must be set in the manner described below to allow the easy access facility to work:

1. The **FN** function must be set to **SPAC** or the **ACCS** function must be set to **EASY**.
2. At least one alarm must have a setpoint, nothing will happen if all the alarm setpoints are set to **OFF**.
3. The **SPAC** function must be set to allow access to the relays required e.g. if set to **A 1-2** then the easy access will work only with alarm relays 1 and 2 even if more relays are fitted.
4. The instrument must be in normal measure mode i.e. if the instrument is powered up so that it is in **CAL** mode then the easy access will not function. If in doubt remove power from the instrument, wait for a few seconds then apply power again.
5. If the easy access facility is used then the only way to view or alter any other function settings is to power up via **CAL** mode i.e. there is no entry to **FUNC** mode functions unless the instrument is powered up in **CAL** mode.

5.1 Alarm relay low setpoint

Display: $RxLo$
Range: Any display value or **OFF**
Default Value: **OFF**

Displays and sets the low setpoint value for the designated alarm relay x . Note x will be replaced by the relay number when displayed e.g. $R1Lo$ for relay 1. Use this low setpoint function if a relay operation is required when the display value becomes equal to or less than the low setpoint value. To set a low alarm value go to the $RxLo$ function and use the \blacktriangle or \blacktriangledown push buttons to set the value required then press **F** to accept this value. The low alarm setpoint may be disabled by pressing the \blacktriangle and \blacktriangledown push buttons simultaneously. When the alarm is disabled the display will indicate **OFF**. If the relay is allocated both a low and high setpoint then the relay will activate when the value displayed moves outside the band set by the low and high setpoints. The value at which the relay will reset is controlled by the $RxHy$ function.

Example:

If $R1Lo$ is set to **10** then relay 1 will activate when the display value is 10 or less.

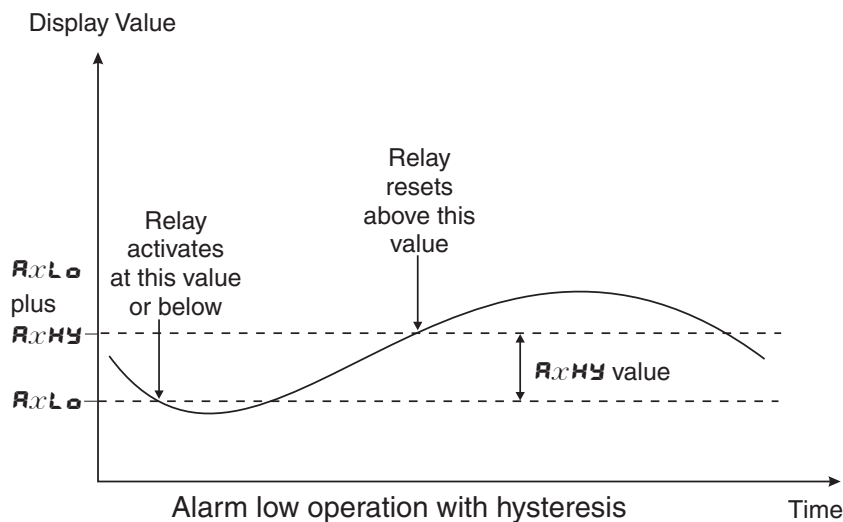

5.2 Alarm relay high setpoint

Display: RxH
Range: Any display value or **OFF**
Default Value: **OFF**

Displays and sets the high setpoint value for the designated alarm relay x . Note x will be replaced by the relay number when displayed e.g. $R1H$ for relay 1. Use this high setpoint function if a relay operation is required when the display value becomes equal to or more than the low setpoint value. To set a high alarm value go to the RxH function and use the \blacktriangle or \blacktriangledown push buttons to set the value required then press **F** to accept this value. The high alarm setpoint may be disabled by pressing the \blacktriangle and \blacktriangledown push buttons simultaneously. When the alarm is disabled the display will indicate **OFF**. If the relay is allocated both a low and high setpoint then the relay will activate when the value displayed moves outside the band set by the low and high setpoints. The value at which the relay will reset is controlled by the $RxHy$ function.

Example:

If $R1H$ is set to **100** then relay 1 will activate when the display value is **100** or higher.

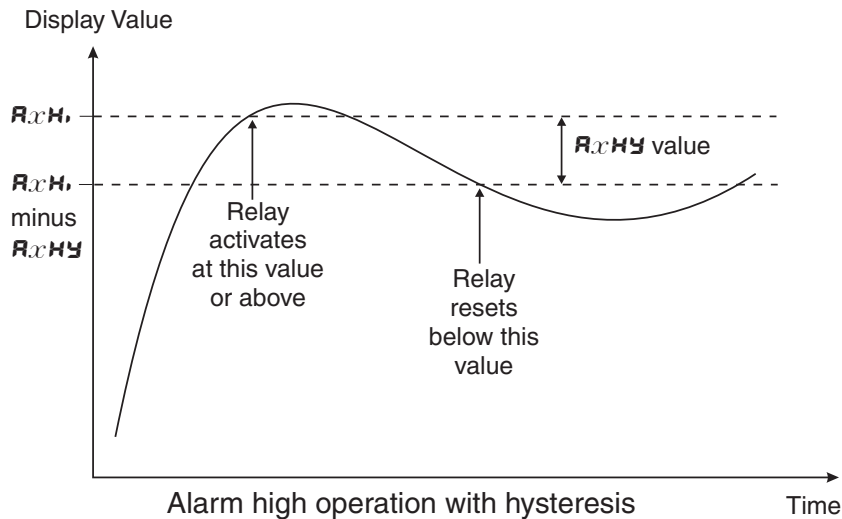

5.3 Alarm relay hysteresis (deadband)

Display: $AxHY$
Range: 0 to 9999
Default Value: 10

Displays and sets the alarm relay hysteresis limit for the designated relay x . Note x will be replaced by the relay number when displayed e.g. $A 1HY$ for relay 1. To set a relay hysteresis value go to the $AxHY$ function and use the \blacktriangle or \blacktriangledown push buttons to set the value required then press \blacksquare to accept this value. The hysteresis value is common to both high and low setpoint values. The hysteresis value may be used to prevent too frequent operation of the relay when the measured value is rising and falling around setpoint value. e.g. if $A 1HY$ is set to zero the alarm will activate when the display value reaches the alarm setpoint (for high alarm) and will reset when the display value falls below the setpoint, this can result in repeated on/off switching of the relay at around the setpoint value.

The hysteresis setting operates as follows: In the high alarm mode, once the alarm is activated the input must fall below the setpoint value minus the hysteresis value to reset the alarm. e.g. if $A 1H$ is to 50.0 and $A 1HY$ is set to 3.0 then the setpoint output relay will activate once the display value goes to 50.0 or above and will reset when the display value goes below 47.0 i.e. at 46.9 or below. In the low alarm mode, once the alarm is activated the input must rise above the setpoint value plus the hysteresis value to reset the alarm. e.g. if $A 1L$ is to 20.0 and $A 1HY$ is set to 10.0 then the alarm output relay will activate when the display value falls to 20.0 or below and will reset when the display value goes above 30.0 i.e. at 30.1 or above. The hysteresis units are expressed in displayed engineering units.

Example: If $A 1H$ is set to 100 and $A 1HY$ is set to 10 then relay 1 will activate when the display value is 100 or higher and will reset at a display value of 89 or lower.

5.4 Alarm relay trip time

Display: $Axtt$
Range: 0 to 9999
Default Value: 0

Displays and sets the alarm trip time in seconds. The trip time is common for both alarm high and

low setpoint values. The trip time provides a time delay before the alarm relay will activate when an alarm condition is present. The alarm condition must be present continuously for the whole trip time period before the alarm will activate. If the input moves out of alarm condition during this period the timer will reset and the full time delay will be restored. This trip time delay is useful for preventing an alarm trip due to short non critical deviations from setpoint. The trip time is selectable over **0** to **9999** seconds. To set a trip time value go to the **AxTt** function and use the **▲** or **▼** push buttons to set the value required then press **F** to accept this value.

Example: If **A1Tt** is set to **5** seconds then the display must indicate an alarm value for a full 5 seconds before relay 1 will activate.

5.5 Alarm relay reset time

Display: **AxrT**
Range: **0** to **9999**
Default Value: **0**

Displays and sets the alarm reset delay time in seconds. The reset time is common for both alarm high and low setpoint values. With the alarm condition is removed the alarm relay will stay in its alarm condition for the time selected as the reset time. If the input moves back into alarm condition during this period the timer will reset and the full time delay will be restored. The reset time is selectable over **0** to **9999** seconds. To set a reset time value go to the **AxrT** function and use the **▲** or **▼** push buttons to set the value required then press **F** to accept this value.

Example: If **A1rT** is set to **10** seconds then the resetting of alarm relay 1 will be delayed by 10 seconds.

5.6 Alarm relay normally open/closed

Display: **Axn.o** or **Axn.c**
Range: **Axn.o** or **Axn.c**
Default Value: **Axn.o**

Displays and sets the setpoint alarm relay *x* action to normally open (de-energised) or normally closed (energised), when no alarm condition is present. Since the relay will always open when power is removed a normally closed alarm is often used to provide a power failure alarm indication. To set the alarm relay for normally open or closed go to the **Axn.o** or **Axn.c** function and use the **▲** or **▼** push buttons to set the required operation then press **F** to accept this selection. **Example:** If set to **A1n.o** alarm relay 1 will be open circuit when the display is outside alarm condition and will be closed (short circuit across terminals) when the display is in alarm condition.

5.7 Alarm relay setpoint or trailing operation

Display: **AxSP** or **Axt I** etc.
Range: **AxSP** or **Axt I** etc.
Default Value: **AxSP**

Relay operation independent setpoint or trailing setpoint, this function will not be seen unless extra optional relays are fitted. Each alarm relay, except relay 1, may be programmed to operate

with an independent setpoint value or may be linked to operate at a fixed difference to another relay setpoint, known as trailing operation. The operation is as follows:

Alarm 1 (**A1**) is always independent. Alarm 2 (**A2**) may be independent or may be linked to Alarm 1. Alarm 3 (**A3**) may be independent or may be linked to Alarm 1 or Alarm 2. Alarm 4 (**A4**) may be independent or may be linked to Alarm 1, Alarm 2 or Alarm 3. The operation of each alarm is selectable by selecting, for example, (Alarm 4) **A4.SP** = Alarm 4 normal setpoint or **A4.t1** = Alarm 4 trailing Alarm 1 or **A4.t2** = Alarm 4 trailing Alarm 2 or **A4.t3** = Alarm 4 trailing Alarm 3. For trailing set points the setpoint value is entered as the difference from the setpoint being trailed. If the trailing setpoint is to operate ahead of the prime setpoint then the value is entered as a positive number and if operating behind the prime setpoint then the value is entered as a negative number.

Example: With Alarm 2 set to trail alarm 1, if **A1H** is set to **1000** and **A2H** is set to **50** then Alarm 1 will activate at **1000** and alarm 2 will activate at **1050** (i.e. 1000 + 50). If Alarm 2 had been set at **-50** then alarm 2 would activate at **950** (i.e. 1000 - 50).

5.8 Preset value

Display: **P.SET**
Range: Any display value
Default Value: **0**

Displays and sets the preset value, this function will not be seen unless either the **F.FNP** or **P.SET** function is set to **P.SET**. The preset value can be used via the remote input or the front panel **P** button to force the display to go to the preset value. A change in the input value will then cause the display to rise or fall from the preset value. To use the remote input to operate the preset functions set the **F.FNP** value to **P.SET**. To use the **P** button to operate the preset function set the **P.but** function to **P.SET**.

5.9 Display brightness

Display: **brgt**
Range: **1** to **15**
Default Value: **15**

Displays and sets the digital display brightness. The display brightness is selectable from **1** to **15**, where **1** = lowest intensity and **15** = highest intensity. This function is useful for improving the display readability in dark areas or to reduce the power consumption of the instrument. See also the **dull** function. To set brightness level go to the **brgt** function and use the **▲** or **▼** push buttons to set the value required then press **F** to accept this value.

5.10 Display remote brightness switching

Display: **dull**
Range: **0** to **15**
Default Value: **1**

Displays and sets the level for remote input brightness switching, see **F.FNP** function. When a remote input is set to **dull** the remote input can be used to switch between the display brightness

level set by the **brgt** function 5.9 and the display brightness set by the **dull** function. The display dull level is selectable from **0** to **15**, where **0** = lowest intensity and **15** = highest intensity. This function is useful in reducing glare when the display needs to be viewed in both light and dark ambient light levels. To set dull level go to the **dull** function and use the **▲** or **▼** push buttons to set the value required then press **F** to accept this value.

Example: With **dull** set to **4** and **brgt** set to **15** and the **FN** function set to **dull** the display brightness will change from the **15** level to **4** when a switch connected to the remote input terminals is activated.

5.11 Bargraph low value

Display: **bar_l**
Range: Any display value
Default Value: **0**

Seen only in bargraph display instruments. Displays and sets the bar graph low value i.e. the value on the 7 segment display at which the bargraph will start to rise. This may be independently set anywhere within the display range of the instrument. Note: The **bar_l** and **bar_h** settings are referenced from the 7 segment display readings, not the bargraph scale values. The bargraph scale may be scaled differently to the 7 segment display. For example the bargraph scale may be indicating percentage fill of a tank whilst the 7 segment display is indicating actual process units. To set bargraph low level go to the **bar_l** function and use the **▲** or **▼** push buttons to set the value required then press **F** to accept this value.

5.12 Bargraph high value

Display: **bar_h**
Range: Any display value
Default Value: **1000**

Seen only in bargraph display instruments. Displays and sets the bar graph high value i.e. the value on the 7 segment display at which the bargraph will reach its maximum indication (e.g. all LEDs illuminated). May be independently set anywhere within the display range of the instrument. To set bargraph high level go to the **bar_h** function and use the **▲** or **▼** push buttons to set the value required then press **F** to accept this value.

5.13 Bargraph type for instruments with bargraph display

Display: **bar_tTYPE**
Range: **bar_t**, **S.dot**, **d.dot**, **C.bAR** or **r.dot**
Default Value: **bar_t**

Bar graph display operation mode - seen only in vertical or circular bargraph display instruments. Allows selection of bargraph operation mode. Choices available are:

- **bar_t** - conventional solid bargraph display i.e. all LEDs illuminated when at full scale. When scaling the display use the **bar_l** and **bar_h** functions e.g. **bar_l = 0** and **bar_h =**

100 will give a bargraph with no segments lit at a 7 segment display reading of **0** and all segments lit with a 7 segment display reading of **100**.

- **S.dot** - single dot display. A single segment will be lit to indicate the input readings position on the scale. When scaling the display use the **bAr₋** and **bAr⁻** functions e.g. **bAr₋ = 0** and **bAr⁻ = 100** will give a bargraph with the bottom segment lit at a 7 segment display reading of **0** and the top segment lit with a 7 segment display reading of **100**. Note: this could also be set up as a centre zero single dot display by entering a negative value and positive value. e.g. **bAr₋ = -100, bAr⁻ = 100**.
- **d.dot** - double dot display. Two segments will be lit to indicate the input reading position on the scale. The reading should be taken from the middle of the two segments. When scaling the display use the **bAr₋** and **bAr⁻** functions e.g. **bAr₋ = 0** and **bAr⁻ = 100** will give a bargraph with the bottom two segments lit at a 7 segment display reading of **0** and the top two segments lit with a 7 segment display reading of **100**. Note: this could also be set up as a centre zero double dot display by entering a negative value and positive value. e.g. **bAr₋ = -100, bAr⁻ = 100**.
- **C.bAr** - centre bar display. The display will be a solid bargraph but will have its zero point in the middle of the display. If the seven segment display value is positive the bargraph will rise. If the seven segment display value is negative then the bargraph will fall. When scaling the display use the **bAr₋** and **bAr⁻** functions e.g. **bAr₋ = 0** and **bAr⁻ = 100** will give a bargraph with all the bottom half segments lit at a 7 segment display reading of **-100** and all the top segments lit with a 7 segment display reading of **100**.
- **r.dot** - modulus or wrap around single dot bargraph. This mode of operation allows the bargraph to wrap around the limits set by the **bAr₋** and **bAr⁻** functions by dividing the 7 segment display by the modulus (the modulus is the difference between 0 and **bAr⁻**) and displaying the remainder. For example if **bAr₋** is set to **0** and **bAr⁻** is set to **10** then in other bargraph modes when the 7 segment display reads a value such as **25** the bargraph would be stuck at the high limit of its travel since it cannot go beyond **10**. In **r.dot** mode the display will wrap around at **10** then continue up the bar again and will be at the midpoint of the bargraph when the 7 segment display shows **25** (as it would for a 7 segment display of **15, 35**, etc.). In this example for a 7 segment display of **25** the value of 25 is divided by the modulus value of 10 in this example and the remainder displayed i.e. 10 goes into 25 twice with the remainder of 5 and so a bargraph position of 5 is displayed. This mode will operate on both vertical and circular bargraph type displays.

5.14 Digital output option mode

Display: **d90P**
 Range: **bcd, b.5CL, b, n** or **b, n2**
 Default Value: **b, n2**

Seen only with the 16 bit digital output option. Refer to the separate “PM4 Panel Meter Optional Output Addendum” booklet supplied when this option is fitted. Selections available are: **b, n2** (signed binary) i.e. -32767 to 32767, **b, n** (unsigned binary) i.e. 0 to 65535, **b.5CL** (scaled binary, see **d, 9-** and **d, 9-** below), **bcd** (binary coded decimal) i.e. up to four BCD numbers. .

5.15 Digital output option polarity

Display: **d9.OP**
Range: **AL** or **AH**
Default Value: **AL**

Seen only with the 16 bit digital output option. Refer to the separate “PM4 Panel Meter Optional Output Addendum” booklet supplied when this option is fitted. Selections available are: **AL** (active low i.e. logic 1 = 0V output, logic 0 = +V output) or **AH**, (active high i.e. logic 1 = +V output, logic 0 = 0V output).

5.16 Digital output option BCD start position

Display: **bcd Start**
Range: **0**, **1** or **2**
Default Value: **0**

Seen only with the 16 bit digital output option. Refer to the separate “PM4 Panel Meter Optional Output Addendum” booklet supplied when this option is fitted. This function affects BCD mode only and determines the number of digits to skip when outputting from the display. As the output is 16 bit it can output up to 4 BCD numbers. Select from **0** to number of display digits minus 4. e.g. for a 6 digit display you may select **0** to **2**, if **2** is selected then the four left most digits will be output, if set to **0** then the four right most digits will be output.

5.17 Digital output option low value

Display: **d, 9-**
Range: Any display value
Default Value: **0**

Seen only with the 16 bit digital output option. Refer to the separate “PM4 Panel Meter Optional Output Addendum” booklet supplied when this option is fitted. Accepts any valid display value. Determines the low scaling point for the **b.SCL** mode and has no effect on other modes. See example which follows in 5.18.

5.18 Digital output option high value

Display: **d, 9^**
Range: Any display value
Default Value: **1000**

Seen only with the 16 bit digital output option. Refer to the separate “PM4 Panel Meter Optional Output Addendum” booklet supplied when this option is fitted. Determines the high scaling point for the **b.SCL** mode and has no effect on other modes.

Example: If **d, 9-** is set to **0** and **d, 9^** is set to **65535** ($2^{16} - 1$) then the retransmission will not be scaled i.e. a display of **2** will cause a retransmission of 2. If **d, 9^** is now changed to **32767** ($2^{15} - 1$) then a display of **2** will cause a retransmission of 4 (note: rounding may occur on retransmission).

5.19 Analog output option low value

Display: ***FEEL***
Range: Any display value
Default Value: ***0***

Seen only when analog retransmission option fitted. Refer to the separate “PM4 Panel Meter Optional Output Addendum” booklet supplied when this option is fitted for wiring details and link settings. Displays and sets the analog retransmission (4–20mA, 0–1V or 0–10V, link selectable) output low value (4mA or 0V) in displayed engineering units. To set the analog output low value go to the ***FEEL*** function and use the **▲** or **▼** push buttons to set the required value then press **F** to accept this selection.

Example: If it is required to retransmit 4mA when the display indicates ***0*** then select ***0*** in this function using the **▲** or **▼** button.

5.20 Analog output option high value

Display: ***FEEL***
Range: Any display value
Default Value: ***1000***

Seen only when analog retransmission option fitted. Refer to the separate “PM4 Panel Meter Optional Output Addendum” booklet supplied when this option is fitted for wiring details and link settings. Displays and sets the analog retransmission (4–20mA, 0–1V or 0–10V, link selectable) output high display value (20mA, 1V or 10V) in displayed engineering units. To set the analog output high value go to the ***FEEL*** function and use the **▲** or **▼** push buttons to set the required value then press **F** to accept this selection.

Example: If it is required to retransmit 20mA when the display indicates ***50*** then select ***50*** in this function using the **▲** or **▼** button.

5.21 Display rounding

Display: ***drnd***
Range: ***1*** to ***5000***
Default Value: ***1***

Displays and sets the display rounding value. This value may be set to 1 - 5000 displayed units. Display rounding is useful for reducing the instrument resolution without loss of accuracy in applications where it is undesirable to display to a fine tolerance. To set the display rounding value go to the ***drnd*** function and use the **▲** or **▼** push buttons to set the required value then press **F** to accept this selection.

Example: If set to ***10*** the display values will change in multiples of 10 only i.e. display moves from ***10*** to ***20*** to ***30*** etc.

5.22 Decimal point

Display: **dCPt**
Range: **0, 0.1** etc.
Default Value: **0**

Displays and sets the decimal point. By pressing the **▲** or **▼** pushbutton at the **dCPt** function the decimal point position may be set. The display will indicate as follows: **0** (no decimal point), **0.1** (1 decimal place), **0.02** (2 decimal places), **0.003** (3 decimal places) and **0.0004** for display with more than 4 digits. Note if the decimal point is altered the display will need to be recalibrated and alarm etc. settings checked.

5.23 Digital filter

Display: **FLtr**
Range: **0** to **8**
Default Value: **2**

Displays and sets the digital filter value. Digital filtering uses a weighted average method of determining the display value and is used for reducing display value variation due to short term interference. The digital filter range is selectable from **0** to **8**, where **0** = none and **8** = most filtering. Use **▲** or **▼** at the **FLtr** function to alter the filter level if required. Note that the higher the filter setting the longer the display may take to reach its final value when the input is changed, similarly the relay operation and any output options will be slowed down when the filter setting is increased. To set the digital filter value go to the **FLtr** function and use the **▲** or **▼** push buttons to set the required value then press **F** to accept this selection.

5.24 **P** button function

Display: **P.but**
Range: **NONE.H, .Lo.HI Lo.ZERO** or **P.SET**
Default Value: **NONE**

P button function - The **P** button (5, 6 or 8 digit LED models only) may be set to operate some of the remote input functions. With the **P.SET** and **ZERO** functions, to prevent accidental operation, the **P** button must be held pressed for 2-3 seconds before the display will go to the preset value or zero. The **P.SET** and **ZERO** functions operations will only work if either the **USCL** or **USER SCALE** function is set to **on**. If both the remote input and **P** button function are operated simultaneously the **P** button will override the remote input. The functions below are as described in the **FLTRP** function below.

5.25 Remote input function

Display: **FINP**
Range: **NONE . P.HLd . d.HLd . H_i . Lo . H_i Lo . ZERO . SP.Ac . No.Ac . CAL.S . P.SET** or **dULL**
Default Value: **NONE**

Remote input function - When these remote input terminals are short circuited, via a switch, relay, keyswitch etc. the instrument will perform the selected remote input function. A message will flash to indicate which function has been selected when the remote input pins are short circuited. The remote input functions are as follows:

NONE - no remote function required i.e. activating the remote input has no effect.

P.HLd - peak hold. The display will show the peak value (highest positive value) only whilst the remote input terminals are short circuited i.e. the display value can rise but not fall whilst the input terminals are short circuited. The message **P.HLd** will appear briefly every 8 seconds whilst the input terminals are short circuited to indicate that the peak hold function is active.

d.HLd - display hold. The display value will be held whilst the remote input terminals are short circuited. The message **d.HLd** will appear briefly every 8 seconds whilst the input terminals are short circuited to indicate that the display hold function is active.

H_i - peak memory. The peak value stored in memory will be displayed if the remote input terminals are short circuited, if the short circuit is momentary then the display will return to normal measurement after 20 seconds. If the short circuit is held for 2 to 3 seconds or the power is removed from the instrument then the memory will be reset.

Lo - valley memory. The minimum value stored in memory will be displayed. Otherwise operates in the same manner as the **H_i** function described above.

H_i Lo - toggle between **H_i** and **Lo** displays. This function allows the remote input to be used to toggle between peak and valley memory displays. The first operation of the remote input will cause the peak memory value to be displayed, the next operation will give a valley memory display. **PH_i** or **PLO** will flash before each display to give an indication of display type.

ZERO - display zero. Either the **USCL** or **USER SCL** function must be set to **on** if the **ZERO** operation is required. When the **ZERO** operation is used the display will show the message **ZERO** and the display value will fall to zero. All zero operations can be reset i.e. cleared via the **CLR ZERO** function if required.

SP.Ac - setpoint access only. This blocks access to any functions except the alarm setpoint functions unless the remote input pins are short circuited or entry is made via **CAL** mode or if the **ACCESS** function is set to **ALL**.

No.Ac - no access. This blocks access to all functions unless the remote input pins are short circuited or entry is made via **CAL** mode or if the **ACCESS** function is set to **ALL**.

CAL.S - calibration select. The remote input can be used to select between scaling values. Two sets of scaling values can be entered in the instrument, one set set of scaling values can be entered with the remote input open circuit and another set with the remote input short circuit to ground. A switch connected to the remote input can then be used to switch between one set and the other. This feature could be used to allow switching between display units each scaled differently e.g. metres and feet. Alternatively it could be used to allow the one display to switch between 2 different encoders with one being setup and scaled with the remote input switch open and the other with the switch closed.

P.SET - preset value. Either the **U.SCL** or **USER SCL** function must be set to **on** if the **P.SET** operation is required. The remote input can be used to force the display to the preset value, this preset value is set at the **P.SET** function. Any changes in the output from the sensor will then add or subtract from the displayed preset value.

dULL - display brightness control. The remote input can be used to change the display brightness. When this mode is selected the display brightness can be switched, via the remote input terminals, between the brightness level set at the **brgt** function and the brightness level set at the **dULL** function.

5.26 Access mode

Display: **ACCS**
Range: **OFF.EASY.NONE** or **ALL**
Default Value: **OFF**

Access mode - the access mode function **ACCS** has four possible settings namely **OFF.EASY.NONE** and **ALL**. If set to **OFF** the mode function has no effect on alarm relay operation. If set to **EASY** the “easy alarm access” mode will be activated. Refer to “Easy alarm relay adjustment access facility” page 13. If set to **NONE** there will be no access to any functions via **FUNC** mode, entry via **CAL** mode must be made to gain access to alarm and calibration functions. If set to **ALL** then access to all functions, including calibration functions, can be gained via **FUNC** mode.

5.27 Setpoint access mode

Display: **SPAC**
Range: **A1.A1-2** etc.
Default Value: **A1**

Setpoint access - seen only if more than 1 relay fitted. Sets the access via **FUNC** mode and “easy alarm access” mode to the alarm relay setpoints. The following choices are available:

A1 - Allows setpoint access to alarm 1 only.

A1-2 - Allows setpoint access to alarms 1 and 2 only.

A1-3 - Allows setpoint access to alarms 1, 2 and 3 etc. up to the maximum number of relays fitted.

The remote input function (**FINP**) must be set to **SPAC** for this function to operate. Note: Only the setpoints which have been given a value will be accessible e.g. if **A1H** is set to **OFF** then there will be no access to the **A1H** function when **SPAC** is used.

5.28 Display input scaling factor

Display: **INPE**
Range: **1** to any positive display value
Default Value: **1**

The **INPE** factor and the **SCL** factor are used to scale the display to read in engineering units e.g. metres. The **INPE** value must always be a whole number, see **SCL** below for formula used.

5.29 Display scaling factor

Display: **SCALE**
Range: 1 to any display value
Default Value: 1

The **SCALE** value is used together with the **INPUT** value to calculate the value to be displayed from the SSI input value transmitted from the encoder. These two functions are used to calculate the display value and are used only when the alternative scaling methods of **USER SCL** and **USER SCALE** are both set to **OFF**. The scale factor can be set to any display value and the decimal point value seen at this function will be set by the **DCPT** function.

If the relevant details of the encoder and display requirements are known the easiest way to find the **INPUT** and **SCALE** values is to use the maximum output value from the encoder as the **INPUT** value and the display value for this maximum output value as the **SCALE** value. For example a 16 bit encoder has an output of 0 to 65535. If you wish this to display 0 to 1500 over the full range of the encoder then set the **INPUT** value to 65535 and the **SCALE** value to 1500.

The display value is calculated in the following manner:

$$\text{Display value} = \frac{\text{Value sent from encoder} \times \text{SCALE}}{\text{INPUT}}$$

Example: A 12 bit SSI encoder will give an output in the range 0 to 4095 (if only positive values are used). The display is to be scaled to show 0.0 to 359.9 over this 12 bit range. With 1 decimal point the **INPUT** value could be set to **4095** and the **SCALE** value set to **359.9** to achieve this i.e. at one quarter output from the encoder (i.e. 1024) the display value is calculated from:

$$\text{Display value} = \frac{1024 \times 359.9}{4095}$$

i.e. Display value = 90.0

5.30 Number of input bits from encoder

Display: **SSI bits**
Range: 1 to 31
Default Value: 1

Displays and selects the number of input bits which the display will interpret as incoming data. This can be set from 1 to 31 bits. For example with an **INPUT** of 1 and a **SCALE** of 1 and 12 bits selected the display will show from 0 to 4095, i.e. the 12 bit binary number range, before returning to 0. Note: If the **SIGN** function is set to **on** then the maximum range displayed in this example is -2048 and 2047. The table which follows gives some examples of the effect of **INPUT**, **SCALE**, **SSI bits** and **SIGN** settings.

INPT	SCALE	SSI BITS	SIGN	Viewable display range
1	1	12	OFF	0 to 4095
1	-1	12	OFF	0 to -4095
1	1	12	on	-2048 to 2047
1	-1	12	on	-2047 to 2048
1	2	12	OFF	0 to 8191
2	1	12	OFF	0 to 2047
1	1	13	OFF	0 to 8191
1	1	14	OFF	0 to 16383
1	1	20	OFF	0 to 1048575
1	1.00	20	OFF	0 to 1048.58
8192	1000	12	OFF	0 to 500

5.31 Sign bit

Display: **SIGN**
Range: **on** or **OFF**
Default Value: **OFF**

Displays and sets the sign bit enabling. With the **SIGN** function set to **on** the data is interpreted as a two's complement signed number, masked to the number of bits set by the **SSI BITS** function. See the **SSI BITS** function above for the effect of the **SIGN** setting on the values displayed for a given number of input bits.

5.32 SSI code type

Display: **SSI Code**
Range: **bin** or **GRAY**
Default Value: **bin**

The input type can be set to **bin** for binary or to **GRAY** for gray code SSI to match the output type from the sensor.

5.33 User simple scaling method

Display: **USCL**
Range: **on** or **OFF**
Default Value: **OFF**

Two point scaling method using a zero or preset operation via a remote input switch or front **P** button as the first scaling point and a **F** button operation to scale as second point. This method provides a simple scaling method without the need to enter the setup functions and is generally used where scaling is to be changed frequently.

Note: 5 or more display digits are required to view fully some of the messages seen in this function.

The user scale function allows the front panel **F** button to be used to enter a scale value. To operate by this method the **U.SCL** function must be set to **on**. If this method of scaling is used the **INPT** and **SCALE** functions are not used and the **USER SCALE** function must be set to **OFF**.

The remote input or **P** button must be used to zero the display with the encoder in its zero position or set the display to a preset value with the encoder at a known position prior to the **U.SCL** operation. See **FUNC** (section 5.25) and **P.but** (section 5.24) functions. The operator then simply moves the encoder to a different known position and then holds the **F** button pressed for approximately 2 seconds. The message **SCALE** will then appear followed by the previous scale value. The value can now be adjusted via the **▲** or **▼** pushbutton. The **F** button is pressed to accept the change or the **P** button can be pressed to abort the scaling. If an error occurs such as trying to give a scaling value to a display reading which is zero then the message **SCALE Error** will be seen.

Example: the sensor is moved to its zero position and a **ZERO** operation carried out via the remote input or **P** button. The sensor is then moved a known distance and the **U.SCL** operation is carried out via the **F** button.

Notes: Easy access (**ACCS** function set to **EASY**) to alarm functions cannot be used if **U.SCL** is set to **on**. If **ACCS** is set to **EASY** or **CAL** when **U.SCL** is set to on then **FUNC** mode entry will operate as the “easy access” mode and entry via **CAL** mode will have to be made to access any other functions.

5.34 Display update rate

Display: **DISP RATE**
Range: **1, 2, 4, 8, 16** or **32**
Default Value: **4**

Displays and sets the display update rate in updates per second e.g. if **4** is selected then the display will update four times per second. The lowest satisfactory update rate should be chosen. If too high a rate is selected then the rapid update may cause an apparent flickering of the display. The update rate affects the display only and does not affect the sampling rate, alarm update etc.

5.35 Clear zero

Display: **CLR ZERO**
Range: n/a
Default Value: n/a

Allows any zero operations performed via the remote input or **P** button to be cleared. Pressing the **▲** and **▼** buttons simultaneously will clear the zero offset, the message **CLrd** will be seen, confirming the zero clearing operation is completed.

5.36 Clear user scale operation

Display: **CLR U.SCL**

Range: n/a

Default Value: n/a

The display scaling via the **U.SCL** function operation can be cleared at this function. Pressing the **▲** and **▼** buttons simultaneously will clear the user scaling and will cause the scaling to revert to a 1:1 equivalent i.e. equivalent to **INPE** function set to **1** and **SCL** function set to **1**. Note that clearing the user scale will not clear any zero or preset operations, the **CLR ZERO** function must be used to clear any zero offsets. If necessary the preset value can be changed at the **P.SET** function and the **P** button or remote input used to activate the preset operation to return the display to the required scaling.

5.37 Two point live input scaling

Display: **USER SCL**

Range: **on** or **OFF**

Default Value: **OFF**

Allows selection of two point live input calibration to be used when this function is set to **on**. This method allows scaling without the need to calculate the required scaling from the SSI encoder/sensor data.

The **CAL 1** and **CAL 2** functions described below can then be used to scale the display. If required the **CAL OFFS** function can be used to make an adjustment to add or subtract an offset value across the display range. The **CAL 1**, **CAL 2** and **CAL OFFS** functions will only be seen when the **USER SCL** function is set to **on**. Note: the **U.SCL** function must be set to **OFF** when the **USER SCL** function is used.

5.38 First calibration scaling point

Display: **CAL 1**

Range: Any display value

Default Value: n/a

This method of display scaling is used only when the **USER SCL** function is set to **on**. **CAL 1** and **CAL 2** are used together to scale the instruments display, values for both must be set when using this scaling method.

The **CAL 1** function sets the first calibration point for live input calibration. When using this method a “live” signal input must be present at the input terminals. Note: **CAL 1** and **CAL 2** can be set independently i.e. it is not necessary to perform a **CAL 2** operation directly after a **CAL 1**. Note that some display rounding may occur if the scaling values entered are larger than the normal binary or Gray code values.

The procedure for entering the first scaling point is:

1. Ensure that an input signal of a know value from an encoder etc. is present at the input terminals, this will normally be at the low end of the range.

2. At the **CAL 1** function press **▲** and **▼** simultaneously, then release them. The display will indicate the live input value. Do not be concerned at this stage if the live input display value is not what is required.
3. Press then release the **F** button. The display will indicate **SCL 1** followed by a value. Use the **▲** or **▼** button to change this value to the required display scale value at this input. Press the **F** button to accept changes, the display will show **CAL End** and will then move on to the next function.

5.39 First calibration scaling point

Display: **CAL 2**
Range: Any display value
Default Value: n/a

This method of display scaling is used only when the **USER SCALE** function is set to **on**. **CAL 1** and **CAL 2** are used together to scale the instruments display, values for both must be set when using this scaling method.

The second point scaling is performed in exactly the same manner as **CAL 1** except that **SCL 2** will be seen instead of **SCL 1**. It is essential that the live input is different in value to the **CAL 1** input. The procedure for entering the second scaling point is:

1. Ensure that an input signal of a know value (different to the input used at **CAL 1**) from an encoder etc. is present at the input terminals, this will normally be at the high end of the range.
2. At the **CAL 2** function press **▲** and **▼** simultaneously, then release them. The display will indicate the live input value. Do not be concerned at this stage if the live input display value is not what is required.
3. Press then release the **F** button. The display will indicate **SCL 2** followed by a value. Use the **▼** or **▲** button to change this value to the required display scale value at this input. Press the **F** button to accept changes, the display will show **CAL End** and will then move on to the next function.

5.40 Calibration offset

Display: **CAL OFFSE**
Range: Any display value
Default Value: n/a

This function will only be seen and can only be used if the **USER SCALE** function is set to **on**.

The calibration offset is a single point adjustment which can be used to alter the calibration scaling values across the entire measuring range without affecting the calibration slope. This method can be used instead of performing a two point calibration when a constant measurement error is found to exist across the entire range. To perform a calibration offset press the **▲** and **▼** buttons simultaneously at the **CAL OFFSE** function. A "live" reading from the input will be seen, make a note of this reading. Press the **F** button, the message **SCALE** will now be seen followed by the last scale value in memory. Use the **▲** or **▼** button to adjust the scale value to the required display

value for that input. For example if the “live” input reading was **50** and the required display value for this input was **70** then adjust the **SCALE** value to **70**.

5.41 Set display operation

Display: **SEt OPER**
Range: **SSI** , **bc8** or **bc24**
Default Value: **SSI**

Allows selection of one of the three main operation mode. Select **SSI** if the input is an **SSI** signal (binary or Gray code) from encoder etc. The remaining two modes are for use only when the instrument is connected to a RM-BC or RM4-BC converter. The two remaining modes are bc8 for 8 bit BCD and bc24 for up to 24 bit BCD inputs. The BCD input can be either parallel, strobed or addressed.

5.42 SSI clock frequency

Display: **SSI FREQ**
Range: **L0** or **H0**
Default Value: **H0**

Allows settings of **L0** (90kHz) or **H0** (600kHz) clock frequencies. The normal setting is **H0** . Use **L0** only if communications difficulties are experienced due to long cable runs.

5.43 Baud rate for optional serial communications

Display: **BAUD FREQ**
Range: **300** . **600** . **1200** . **2400** . **4800** . **9600** . **19.2** or **38.4**
Default Value: **9600**

Set baud rate - seen only with serial output option. Refer to the separate “PM4 Panel Meter Optional Output Addendum” booklet supplied when optional outputs are fitted. Select from **300** . **600** . **1200** . **2400** . **4800** . **9600** . **19.2** or **38.4** baud. The baud rate should be set to match the device being communicated with.

5.44 Parity for optional serial communications

Display: **Prty**
Range: **NONE** . **EVEN** or **odd**
Default Value: **NONE**

Set parity - seen only with serial output option. Refer to the separate “PM4 Panel Meter Optional Output Addendum” booklet supplied when optional outputs are fitted. Select parity check to either **NONE** , **EVEN** or **odd**. The parity should be set to match the device being communicated with.

5.45 Output mode for optional serial communications

Display: **0.Puk**
Range: **d: SP, Cont, POLL, R.buS** or **ā.buS**
Default Value: **Cont**

Set serial interface mode - seen only with serial output option. Refer to the separate “PM4 Panel Meter Optional Output Addendum” booklet supplied when optional outputs are fitted. Allows user to select the serial interface operation as follows:

d: SP - sends image data from the display without conversion to ASCII.

Cont - sends 8 bit ASCII form of display data at a rate typically 90% of the sample rate.

POLL - controlled by computer or PLC as host. Host sends command via RS232/485 and instrument responds as requested.

R.buS - is a special communications mode used with Windows compatible optional PC download software. Refer to the user manual supplied with this optional software.

ā.buS - Modbus RTU protocol.

5.46 Instrument address for optional serial communications

Display: **Addr**
Range: **0** to **31**
Default Value: **0**

Set unit address for polled (**POLL**) or **ā.buS** mode (**0** to **31**) - seen only with serial output option. Refer to the separate “PM4 Panel Meter Optional Output Addendum” booklet supplied when optional outputs are fitted. Allows several units to operate on the same RS485 interface reporting on different areas etc. The host computer or PLC may poll each unit in turn supplying the appropriate address. The unit address ranges from 0 to 31 (DEC) but is offset by 32 (DEC) to avoid clashing with ASCII special function characters (such as <STX> and <CR>). Therefore 32 (DEC) or 20 (HEX) is address 0, 42 (DEC) or 2A (HEX) is address 10. Do not use address 0 in **ā.buS** mode.

5.47 Returning to normal measure mode

When the calibration has been completed it is advisable to return the instrument to the normal mode (where calibration functions are less likely to be tampered with). To return to normal mode, turn off power to the instrument, wait a few seconds and then restore power.

5.48 Error Messages

- **-or-** - this message means that the number being received is too big to display e.g. **123456** cannot be displayed on a 5 digit display.

- **SCALE Error** - this message means that an error occurred whilst attempting to scale the display. Check that the sensor is connected correctly and that the scaling method was followed correctly.

6 BCD Converter Input Functions

This chapter covers extra functions seen when the **SEt OPER** function is set to bc 8 or bc24. See “Explanation of Functions” chapter 5 for a description of the alternative operation mode and for functions common to each mode.

When **bc 8** or **bc24** operation mode is selected the PM4-SSI must receive its SSI input from a model RM-BC or RM4-BC converter. These instruments convert a BCD input signal to SSI. The input can be selected as either parallel, strobed or addressed BCD. Refer to the instruction manual supplied with the converter for details of electrical connections and required PM4-SSI function settings for the electrical input type being used.

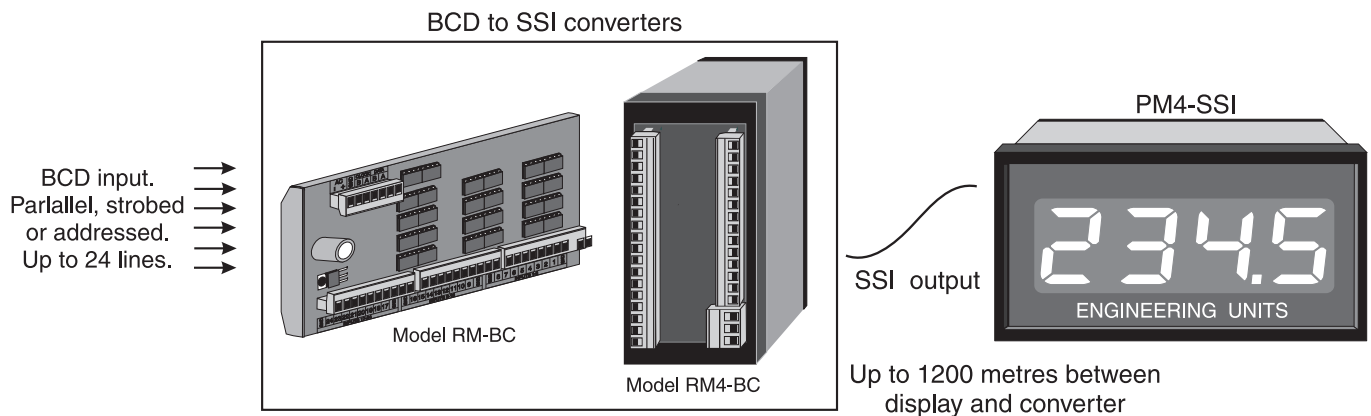

The PM4 setup and scaling functions are configured through a push button sequence. Refer to the diagram on page 10 for details on accessing setup functions.

Explanation of functions

SEt bcd - (select input mode) This function is used to select the input type to be used. Select **PARL** for a multiparallel input, select **Strb** for a strobed input or select **Addr** for an addressed input type.

DATA POL - (input data polarity) Select **Lo** for active low BCD input signals or **Hi** for active high BCD input signals.

Strb POL - (strobe polarity) Select **Lo** for active low strobe input or **Hi** for active high strobe input.

bcd CODE - (code for non BCD characters) Select the format for non BCD inputs i.e. A to F or 1010 to 1111.

0 - A to F (1010 to 1111) displays blanks

1 - A to F (1010 to 1111) displays **A, b, C, d, E, F**

2 - A to F (1010 to 1111) displays **-, C, i, o, o**, blank

3 - A to F (1010 to 1111) displays **A, L, H, i, o**, blank

4 - A to F (1010 to 1111) displays **o, C, F, -, -, -**

5 - A to F (1010 to 1111) displays **-, E, H, L, P**, blank

bcd d, 9t - (number of digits to display) Displays and sets the number of digits to display. Settings available range from 1 to the number of display digits available e.g.1 to 5 on a 5 digit display. Note: that an 8 bit converter using parallel input will only allow a 2 digit display.

SEt OPER - (set operation mode) Allows selection of one of the three main operation mode. Select SSI if the input is an SSI signal (binary or Gray code) from encoder etc. The remaining two modes are for use only when the PM4-SSI is connected to a RM-BC or RM4-BC converter. The two remaining modes are **bc8** for 8 bit BCD and **bc24** for up to 24 bit BCD inputs. The BCD input can be either parallel, strobed or addressed.

7 Specifications

7.1 Technical specifications

Input :	Synchronous Serial Interface (SSI) selectable as binary or Gray code (up to 31 bits) or 8 or 24 bit via model RM4-BC or RM-BC converter.
Clock frequency	60kHz or 90kHz user selectable
Microprocessor:	HC68HC11 CMOS
Ambient temperature:	LED -10 to 60° C, LCD -10 to 50° C
Humidity:	5 to 95% non condensing
Display:	LED Models: 4 digit 20mm, 5 digit 14.2mm + status LEDs + 4 way keypad. 6 digit 14.2mm + 4 way keypad LCD Models: 4 digit 12.7mm, 6 digit 12.7mm
Power Supply:	AC 240V, 110V or 24V 50/60Hz or DC isolated wide range 12 to 48V. Notes: supply type is factory configured. 4 digit displays not suitable for U.S.C.L scaling mode.
Power Consumption:	AC supply 4 VA max, DC supply typically 80mA at 12VDC and 35mA at 24VDC for 40mA at 24VDC for PM4 with LED display and no optional outputs. Typically 50mA at 12VDC and 35mA at 24VDC for PM4 with LCD display and no optional outputs, actual current drawn depends on display type and options fitted
Output (standard):	1 x relay, Form A, rated 5A resistive
Relay Action:	Programmable N.O. or N.C

7.2 Optional outputs

Extra Relays:	Same specs. as Relay 1 (up to 6 extra relays). Available as one, three or six extra relays.
Analog Retransmission:	12 bit isolated 4 to 20mA, 0 to 1V or 0 to 10V link selectable (4-20mA will drive into resistive loads of up to 800Ω)
Serial Communications:	Isolated RS232 or RS485 (ASCII or Modbus RTU)
DC Voltage output:	Isolated, regulated ±12V (24VDC) standard or ±5V (10VDC). Rated output current 25mA max.

7.3 Physical Characteristics

Bezel Size:	DIN 48mm x 96mm x 10mm
Case Size:	44mm x 91mm x 120mm behind face of panel
Panel Cut Out:	45mm x 92mm +1mm/-0mm
Connections:	Plug in screw terminals (max. 2.5mm ² wire)
Weight:	400 gms basic model, 450 gms with option card

8 Guarantee and service

The product supplied with this manual is guaranteed against faulty workmanship for a period of two years from the date of dispatch.

Our obligation assumed under this guarantee is limited to the replacement of parts which, by our examination, are proved to be defective and have not been misused, carelessly handled, defaced or damaged due to incorrect installation. This guarantee is VOID where the unit has been opened, tampered with or if repairs have been made or attempted by anyone except an authorised representative of the manufacturing company.

Products for attention under guarantee (unless otherwise agreed) must be returned to the manufacturer freight paid and, if accepted for free repair, will be returned to the customers address in Australia free of charge.

When returning the product for service or repair a full description of the fault and the mode of operation used when the product failed must be given. In any event the manufacturer has no other obligation or liability beyond replacement or repair of this product.

Modifications may be made to any existing or future models of the unit as it may deem necessary without incurring any obligation to incorporate such modifications in units previously sold or to which this guarantee may relate.

This document is the property of the instrument manufacturer and may not be reproduced in whole or part without the written consent of the manufacturer.

This product is designed and manufactured in Australia.