

PM4-MS

DC Current / DC Voltage
Auto/Manual Station

Operation and Instruction Manual

(Inputs 4-20mA, 0-1V, 0-10V & 0-100V)

AMALGAMATED INSTRUMENT CO PTY LTD

ACN: 001 589 439

Unit 5, 28 Leighton Place Hornsby
NSW 2077 AUSTRALIA

Telephone: +61 2 9476 2244
Facsimile: +61 2 9476 2902

e-mail: sales@aicpl.com.au
Internet: www.aicpl.com.au

Introduction	1
Read This First	2
Mechanical Installation	3
Electrical Installation	4
Alarm Relays	5
Alarm Low Setpoint	5
Alarm High Setpoint	5
Alarm Hysteresis.	5
Alarm Relay N/O or N/C Operation	6
Alarm Trip Time	6
Alarm Relay 1 Auto/manual Function	6
Output Options	7
Additional Alarm Relays	7
DC Voltage Output	7
Explanation of Functions.	8
Setting up the Instrument.	13
Step 1, Entering the setup mode	13
Step 2, Stepping through the settings	13
Step 3, Making changes to the settings	13
Function Table	14
Auto/Manual Functions	15
Calibration	17
Hardware Configuration.	20
Selecting the input range.	20
Configuring the output board.	21
Specifications	22
Technical Specifications	22
Output Options	22
Physical Characteristics	22
Guarantee and Service	23

Introduction

This manual contains information for the installation and operation of the AIC PM4-MS Auto/Manual Station. The PM4-MS is an versatile instrument which may be configured to accept inputs of DC volts (0-1v or 0-10v) or 4 to 20 mA DC and retransmit a direct or manually controlled analog output of DC volts (0-1v or 0-10v) or 4 to 20mA. The instrument may be calibrated to display the input in engineering units. A standard inbuilt relay provides an alarm/control function, an optional 2nd relay and excitation voltage may also be provided.

Unless otherwise specified at the time of order, your PM4 has been

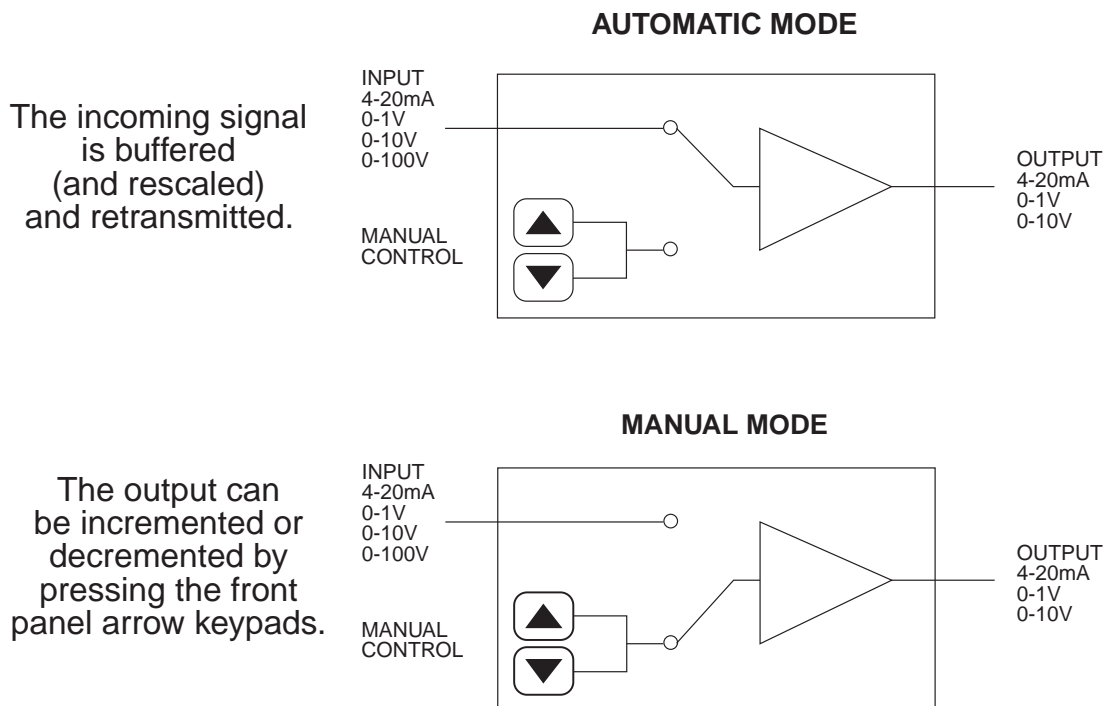

factory set to a standard configuration. Like all other PM4 series instruments the configuration and calibration is easily changed by the user. Initial changes may require dismantling the instrument to alter PCB links, other changes are made by push button functions.

Full electrical isolation between power supply, input voltage or current and retransmission output is provided by the PM4, thereby eliminating grounding and common voltage problems. This isolation feature makes the PM4 ideal for interfacing to computers, PLC,s and other data acquisition or control devices.

The PM4 series of Panel Mount Monitors are designed for high reliability in industrial applications. The high brightness LED display provides good visibility, even in areas with high ambient light levels. The wide combination of input to output voltage and current ranges allows the PM4-MS to perform a signal conversion as well as auto manual function.

Read This First

Your new PM4 monitor has been supplied factory configured (unless otherwise specified), as follows:

Input:	4 to 20mA
Calibration:	0 to 1000
Relay 1 Low Setpoint:	Off
Relay 1 High Setpoint:	Off
Relay 1 Status:	High Alarm
Relay 1 Hysteresis:	0.1
Relay 1 Trip Time:	0
Relay 1 Action:	N/O (ie, de-energised when no alarm)
Decimal Point:	0.1
Display Rounding:	0.1
Digital Filter:	3 (range 0-8. ie, 0=min & 8=max)
Retransmission Type:	4 to 20mA standard (0-1V & 0-10V by internal link selection)
Retransmission Low:	0
Retransmission High:	100.0
Remote Input:	Selects auto or manual via momentary contact closure

Options (when fitted)

Relay 2:	(same settings as Relay 1)
Excitation Voltage:	Isolated ± 12 VDC (24V) or ± 5 V (10V) internal link selection

Input/output Configuration

If you need to change the input or output type from 4 to 20mA to DC volts, proceed as follows:

- Remove plug-in input terminal(s).
- Unscrew 4 x 2g self tapping screws from back cover.
- Remove back cover.
- Loosen earth screw.
- Slide out the printed circuit board.
- Configure PCB links as shown in section "Hardware Configuration".
- Slide printed circuit board back into the instrument case.
- Make sure the earth screw is tightened.
- Refit and secure back cover and plug-in terminals.

Mechanical Installation

If a choice of mounting sites is available then choose a site as far away as possible from sources of electrical noise such as motors, generators, fluorescent lights, high voltage cables/bus bars etc. An IP65 access cover which fixes over the front of the instrument is available, as an option, to be used when mounting the instrument in damp/dusty positions. A wall mount case is available, as an option, for situations in which panel mounting is either not available or not appropriate. A portable carry case is also available, as an option, for panel mount instruments.

Prepare a panel cut out of 45mm x 92mm +1 mm / -0 mm (see diagram below). Insert the instrument into the cut out from the front of the panel. Then from the rear of the instrument, fit the two mounting brackets into the recess provided (see diagram below). Whilst holding the bracket in place, tighten the securing screws being careful not to over-tighten, as this may damage the instrument.

Hint: use the elastic band provided to hold the mounting bracket in place whilst tightening securing screws.

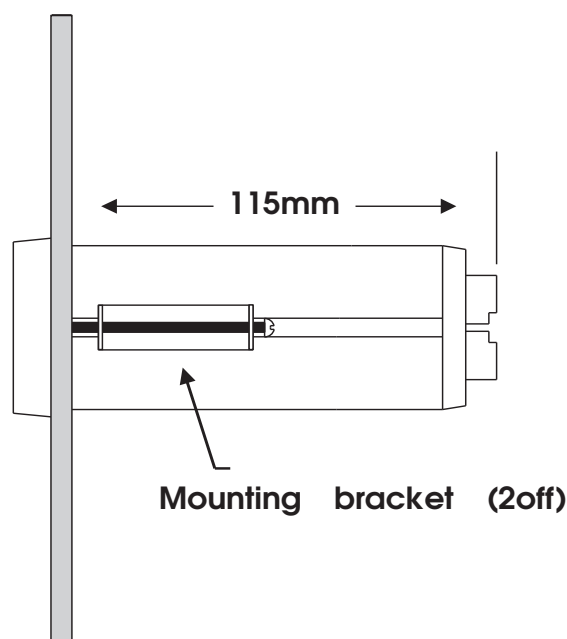
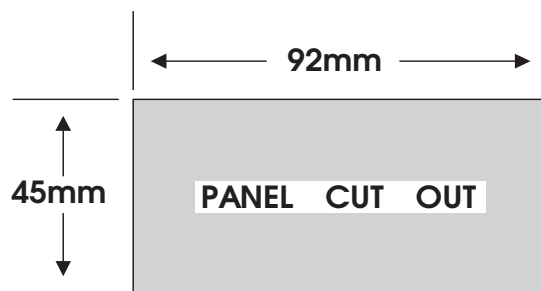

Side view of mounting panel

Electrical Installation

The PM4 Panel Meter is designed for continuous operation and no power switch is fitted to the unit. It is recommended that an external switch and fuse be provided to allow the unit to be removed for servicing.

The terminal blocks allow for wires of up to 1.5mm to be fitted. Connect the wires to the appropriate terminals as indicated below. Refer to other details provided in this manual to confirm proper selection of voltage, polarity and input type before applying power to the instrument. When power is applied the instrument will cycle through a display sequence, indicating the software version and other status information, this indicates that the instrument is functioning. Acknowledgment of correct operation may be obtained by applying an appropriate input to the instrument and observing the resultant reading.

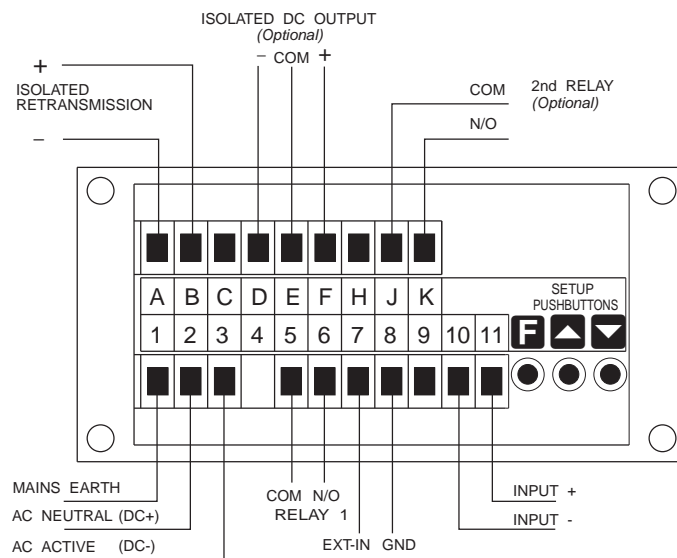

Instrument Rear Panel

AMALGAMATED INSTRUMENT CO PTY LTD 5/28 LEIGHTON PL, HORNSBY. NSW 2077 AUSTRALIA PH: (02) 476 2244 FAX: (02) 476 2902	
1 MAINS EARTH 2 240VAC NEUTRAL 3 240VAC ACTIVE	RETRANSMISSION A OUTPUT V/I - B UTPUT V/I ++
OPTIONAL OUTPUTS	
5 RELAY 1 COM 6 RELAY 1 N/O 7 EXT IN 8 GROUND	C D DC VOLTS O/P - E DC VOLTS O/P GND F DC VOLTS O/P ++
9 10 INPUT - 11 INPUT ++	H J RELAY 2 COM K RELAY 2 N/O
MODEL No: PM4-MS-240-5E-A	SERIAL No:

Instrument Data Label (example)

Alarm Relays

The PM4 is provided with 1 alarm relay. An optional totally independent 2nd alarm relay may also be provided. These are designated 'ALARM 1' and 'ALARM 2'. Each alarm has the following parameters which may be set by the user:

- 1 Low trip point, adjustable in measurement units.
- 2 High trip point, adjustable in measurement units.
- 3 Alarm hysteresis, adjustable in measurement units.
- 4 Alarm trip time, adjustable in seconds.
- 5 N/O or N/C relay operation

The alarm operates in the following way:

If the measured value is above the High Trip Point, or below the Low Trip Point, the alarm trip timer starts. This timer is reset if the measured value drops below the High Trip Point or above the Low Trip point. When the alarm trip timer's time exceeds the Trip delay time, the alarm is operated.

When the alarm has tripped, the measured value is compared to the High Set Point less the Hysteresis value and the Low Set Point plus the Hysteresis value. If it is less than the High Set Point less the Hysteresis value and greater than the Low Set Point plus the Hysteresis value, the alarm is reset.

5.1 Alarm Low Setpoint

The low setpoint may be programmed to operate the alarm relay when the measured value falls below the set value. If the low setpoint is not required, it may be set to "OFF" in the setup mode. The instrument is configurable for each relay to have a low and a high setpoint, so the relay may be triggered if the reading deviates outside of the setpoint limits.

5.2 Alarm High Setpoint

The high setpoint may be programmed to operate the alarm relay when the measured value exceeds the set value. If the high setpoint is not required, it may be set to "OFF" in the setup mode.

5.3 Alarm Hysteresis

The hysteresis value is used to prevent too frequent operation of the alarm relay when the measured value stays close to the setpoint. The hysteresis value is common to the high and low relay action for each alarm.

5 .4 Alarm Relay N/O or N/C Operation

Each alarm may be programmed to operate as a normally open (N/O) or normally closed (N/C) device. A N/O relay is de-energised when no alarm condition is present and is energised when an alarm condition is present. A N/C relay is normally energised and is de-energised when an alarm condition is present. The N/C mode is useful for power failure detection.

5 .5 Alarm Trip Time

The alarm trip time determines how long the measured value has to be above the high trip point or below the low trip point before an alarm is given. This can be used to prevent false alarms on noisy inputs. The value is set in seconds, with a range of 0 - 60 seconds. For normal operation a delay of three to five seconds is suitable.

5 .6 Alarm Relay 1 Auto/manual Function

Alarm relay 1 may operate as a normal alarm or to indicate when the unit is in the Auto or Manual mode. Refer to “inPt” function for more information (chapters “Auto/Manual Functions” and “Explanation of Functions”).

Output Options

The basic PM4 is provided with a single alarm relay output. Optional outputs may be provided as follows:

6 .1 Additional Alarm Relays

The 2nd alarm relay has the same programmable functions and specifications as the 1st (standard) alarm relay (note a 3rd relay is available for some models). The programming messages are automatically updated to include settings for the additional relay(s).

6 .2 DC Voltage Output

An isolated DC voltage output is available to power external transducers etc. The standard output is (12V (24V), the output may be changed to a (5V(10V) by a PCB link selector.

Note: where a 24V DC output is required connect between +12V and -12V (+5V and -5V for 10V outputs).

Explanation of Functions

The PM4 setup and calibration functions are configured through a pushbutton sequence, as explained in “setting up the instrument” and “calibration”. Two levels of access are provided for setting up and calibrating - level 1 (simple pushbutton sequence) allows access to commonly set up functions, level 2 (power up sequence plus pushbutton sequence) allows access to calibration parameters. Note; certain functions relating to the optional retransmission output limits are only displayed when the retransmission option is fitted. Changes to the setpoints and other functions are made by pressing the ▲ and ▼ pushbuttons. Described below is a brief description of each function.

Set up functions (see also chapter titled “Setting up the instrument”).

To enter the set up mode, a simple pushbutton sequence is necessary (this prevents accidental alteration of settings). First press the “F” button and then (within 2 seconds) press both the ▲ and ▼ pushbuttons simultaneously. The display will now read “FUNC” thereby indicating that you have entered the Setup Function Mode. Each function may be accessed by pressing the F pushbutton to step through the functions as indicated below. Note; The P button (only on models with 4 x front panel pushbuttons) may be used to exit the function mode at any time and will abort the function currently displayed without accepting any changes to that function. This is useful for quickly exiting the function mode and as a means preventing accidental or unwanted changes to the functions.

“Chng” (change between auto to manual).

Selects between “Auto” (auto ie. direct transfer between input and output) and “LOCAL” (local ie. manual mode). By pressing the ▲ or ▼ pushbuttons the display will toggle between “Auto” & “LOCAL”. Pressing the F button will set the instrument to auto or manual. When changing from auto to manual, the manual value is set to the current auto value thus achieving a bumpless transfer function. When changing from manual to auto, the manual output will ramp towards the auto value at a programmable rate (see “dLAY” function).

note: to enter the following functions, do not alter the “Chng” setting, continue by pressing the F button to step through the functions.

“inPt” (select operation of external input).

This function is accessible via the calibration function only (see calibration)

May be set to either “OFF”, “on” or “toGL” and determines what external input operation is required to switch from Auto to Manual or vice versa.

If set to “OFF” the unit will be in the Auto mode when the remote input is open (and changes to manual mode when contacts are closed).

If set to “on” the unit will be in the Auto mode when the remote input is

closed (and changes to manual mode when contacts are closed).

If set to “**to9L**” the unit will change from Auto to Manual or vice versa every time the remote input is closed (momentary action).

Note: If this function is set to “**OFF**” or “on” then the “**Ch9**” function will not be available.

“**rly1**” (select operation of relay 1).

This function is accessible via the calibration function only (see calibration)



May be set to either “**AL**” or “**ctRL**”.

“**AL**” selects normal alarm operation as described in “Alarm Relays” chapter.



“**ctRL**” selects Manual Mode Indication. In this mode Alarm Relay 1 will be de-energised when the instrument is in the Auto Mode and energised in the Manual Mode.

Note: If this function is set to “**ctRL**” the Alarm 1 setpoint functions will not be accessible. You may select “**R In.o**” or “**R In.c**” to change the relay contact status as required.



“**A1Lo**” (alarm 1 low setpoint).

Displays and sets the alarm 1 low setpoint value. The low alarm setpoint may be disabled by pressing the  and  pushbuttons simultaneously. When the alarm is disabled the display will indicate “**OFF**”. Alarm 1 will trip when the displayed value is lower than the “**R 1Lo**” setpoint value.



“**A1Hi**” (alarm 1 high setpoint).

Displays and sets the alarm 1 high setpoint value. The high alarm setpoint may be disabled by pressing the  and  pushbuttons simultaneously. When the alarm is disabled the display will indicate “**OFF**”. Alarm 1 will trip when the displayed value is higher than the “**R 1H,**” setpoint value.

“**A2Lo**” (alarm 2 low setpoint).

Displays and sets the alarm 2 low setpoint value. The low alarm setpoint may be disabled by pressing the  and  pushbuttons simultaneously. When the alarm is disabled the display will indicate “**OFF**”. Alarm 2 will trip when the displayed value is lower than the “**R2Lo**” setpoint value.

“**A2Hi**” (alarm 2 high setpoint).

Displays and sets the alarm 2 high setpoint value. The high alarm setpoint may be disabled by pressing the  and  pushbuttons simultaneously. When the alarm is disabled the display will indicate “**OFF**”. Alarm 2 will trip when the displayed value is higher than the “**R2H,**” setpoint value.

“**A1Hy**” (alarm 1 hysteresis [deadband]).

Displays and sets the alarm 1 hysteresis limit and is common for both high and low setpoint values. In the high alarm mode once the alarm is tripped the input must fall below the setpoint value minus the hysteresis

value to reset the alarm. In the low alarm mode once the alarm is tripped the input must rise above the setpoint value plus the hysteresis value to reset the alarm. The hysteresis units are expressed in displayed engineering units.

“A2Hy” (alarm 2 hysteresis [deadband])

Displays and sets the alarm 2 hysteresis limit (as per “A1Hy”).

“A1tt” (alarm 1 trip time).

Displays and sets the alarm 1 trip time and is common for both alarm 1 high and low setpoint values. The trip time is the delay before the alarm will trip. The alarm condition must be present continuously for the trip time period before the alarm will trip. This function is useful for preventing an alarm trip due to short non critical deviations from setpoint. The trip time is selectable over 0 to 60 seconds.

“A2tt” (alarm 2 trip time).

Displays and sets the alarm 2 trip time (as per “A1tt”).

“A1n.o or A1n.c” (alarm 1 normally open or normally closed)

Displays and sets the alarm relay 1 action to normally open (de-energised) or normally closed (energised), when no alarm condition is present.

“A2n.o or A2n.c” (alarm 2 normally open or normally closed)

Displays and sets the alarm relay 2 action to normally open (de-energised) or normally closed (energised), when no alarm condition is present.

“BAr_” (bar graph display low value)

Displays and sets the bar graph low value. May be independently set anywhere within the display range of the instrument.

“BAr” (bar graph high value).

Displays and sets the bar graph high value. May be independently set anywhere within the display range of the instrument.

“rEC_” (recorder/retransmission output low value)

Displays and sets the analog retransmission (4 to 20mA, 0-1V or 0-10V) output low value (4mA or 0V) in displayed engineering units.

“rEC” (recorder/retransmission output high value).

Displays and sets the analog retransmission (4 to 20mA, 0-1V or 0-10V) output high value (20mA, 1V or 10V) in displayed engineering units.

“dLAY” (manual to auto ramp delay).

Sets the delay time for the manual to auto ramp (1 to 255 seconds). This sets the time it will take to ramp over the entire retransmission output range.

“drnd” (display rounding).

Displays and sets the display rounding value. This value may be set to 0 - 5000 displayed units. Display rounding is useful for reducing the instrument resolution without loss of accuracy, in applications where it is undesirable to display to a fine tolerance. (example if set to 10 the instrument will display in multiples of 10).

“dCPt” (decimal point selection).

Displays and sets the decimal point. By pressing the $\left[\right]$ or \oplus pushbuttons the decimal point position may be set. The display will indicate as follows: “0” (no decimal point), “0.1” (1 decimal place), “0.02” (2 decimal places), “0.003” (3 decimal places).

“Fltr” (digital filter)

Displays and sets the digital filter value. Digital filtering is used for reducing susceptibility to short term interference. The digital filter range is selectable from 0 to 8, where 0 = none and 8 = most filtering. A typical value for the digital filter would be 3.

Calibration functions (see also chapter titled “Calibration”).

To enter this mode a special “power up procedure must be followed” this procedure prevents accidental alteration of calibration and provides a degree of calibration security.

Turn off the instrument power.

Press and hold the **F** button whilst applying power to the instrument. The instrument will display “CAL” indicating that the calibration level of the function mode may be accessed.

Now enter the function set up mode as described above “entering the set up mode” and step through the functions until the display indicates “CAL”.

“CAL1 & CAL2” (calibration by applying an input signal)

Displays and sets the two independent calibration/scaling points of the input to the display. See calibration chapter for full details of setting up. Enter “CAL 1” input value, “SCL 1” scaling/displayed value, then enter “CAL 2” input value and “SCL 2” scaling/displayed value. The calibration of these points may also be carried out as independent operations.

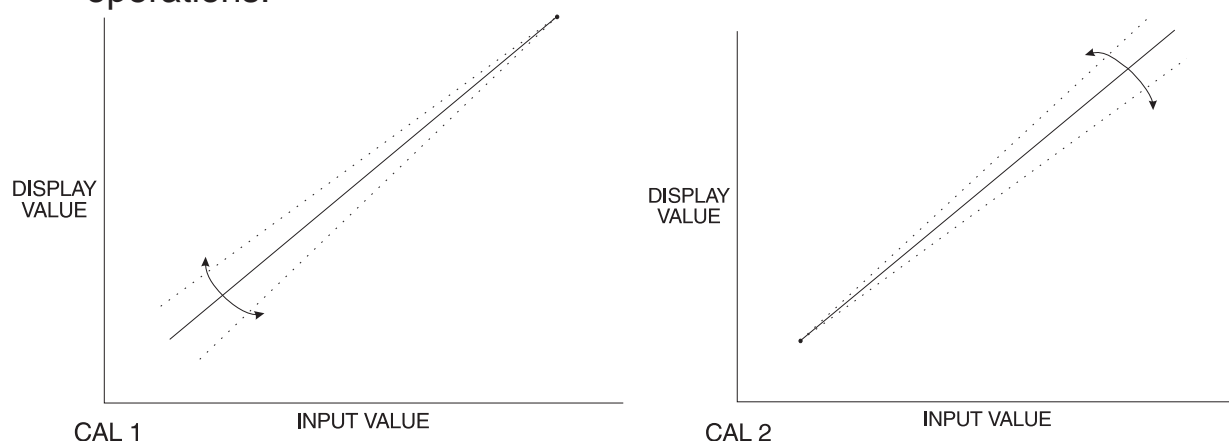

“**OFS**” (offset calibration)

Allows the instrument calibration to be offset by a single point value. This value is added or subtracted across equally the range of the instrument.

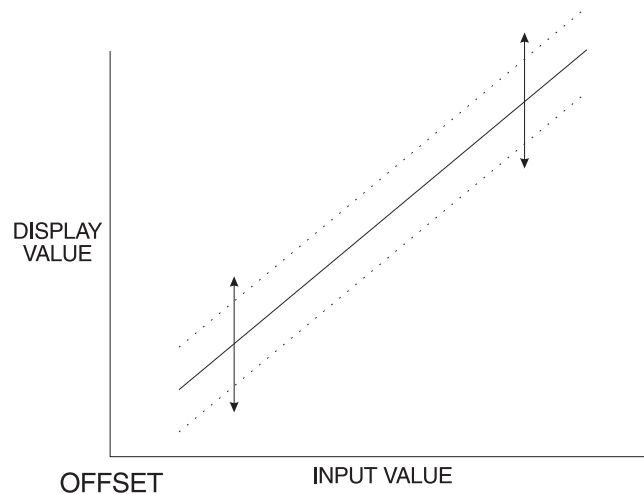

“**SCLE**” (Input scaling by keying in 4 to 20mA values)

The instrument may be calibrated without using test equipment (on the 4 to 20mA input only). The display reading at 4mA and at 20mA are programmed in as scaling values.

“**UCAL**” (uncalibration).

Used to set the instrument back to the factory calibration values. This function should only be used when calibration problems exist, and it is necessary to clear the calibration memory.

Returning to the normal measure mode

When the calibration procedure has been completed it is advisable to return the instrument to the normal mode (where calibration functions cannot be tampered with). To return to the normal mode, turn off power to the instrument, wait a few seconds and then restore power.

Setting up the Instrument

Setting up and calibrating the PM4 is extremely easy, since most functions are changed or viewed by pressing the pushbuttons. The instruments may have rear accessible pushbuttons, some versions also have front panel keypads which perform the same functions. Note: some initial configuring may require dismantling the instrument to alter selection links (see sections on hardware configuration).

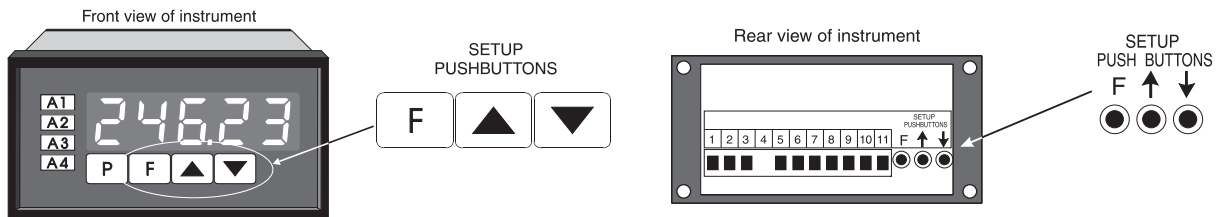

8.1 Step 1 - Entering the Function Setup Mode

To enter the setup mode a simple pushbutton sequence is necessary (this prevents accidental alteration of settings). First press, then release, the **F** button and then (within 2 seconds) press, then release, both the **▲** and **▼** buttons simultaneously. The display will now read **FUNC** indicating that you have entered the Function Setup Mode

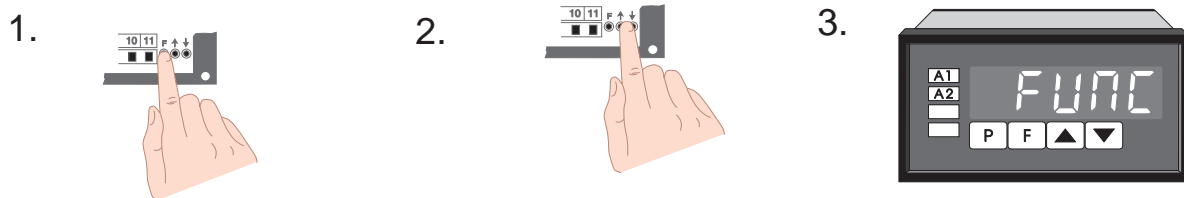



8.2 Step 2 - Stepping through the settings

The display of **FUNC** is followed by the first setup message **A 1 L o** (Alarm 1 Low setting). As with all other messages the first display lets you know which parameter will be affected when changes are made. Each time the **F** button is pressed and released another setup parameter is displayed (see "Function Table" for list of functions). After the last function the display returns to the normal process display.

8.3 Step 3 - Making changes to the settings

Whilst still in the Function Setup Mode, press the **F** button until you reach the parameter you wish to change. Initially the display will indicate the particular function (e.g. **A 1 L o**), this will be followed by a display showing the current status of that setting (e.g. **50.0**). The setting may now be changed by pressing the **▲** or **▼** pushbutton until the desired value is displayed. You may then proceed through the functions until you reach the

next function that you wish to change or until you exit the function mode.

Note 1: Remember the alarm relays may be configured to have both a high and a low setting. If the relay is required to trip at only one point (e.g. **R 1H**, high alarm only) turn off **the unwanted setpoint by selecting the unwanted setting (e.g. R 1Lo)** and press the  and  pushbuttons simultaneously. The display will now indicate **OFF** confirming that Alarm Relay 1 will only trip when the display value is higher than the setpoint value.

Note 2: Instruments with front panel pushbuttons have an additional button (**P** button). Pressing this button in the setup or calibrate mode exits the current function leaving it unchanged. This is useful for aborting a current function or a method of quickly exiting the function mode by stepping to the next function and then pressing the **P** button.

Function table for fully optioned instrument

Initial display	Meaning of display	Next display	Record Your Settings
Chng	Change Between Auto & Manual	Auto or LCAL (manual)	
InPt	Select Remote Input Function	OFF, on or togl <i>(accessible via calibration mode)</i>	
rly1	Alarm 1 Relay Operation	AL or ctrl <i>(accessible via calibration mode)</i>	
A1Lo	Alarm 1 Low Setpoint Value	Setpoint Value or OFF	
A1 Hi	Alarm 1 High Setpoint Value	Setpoint Value or OFF	
*A2Lo	Alarm 2 Low Setpoint Value	Setpoint Value or OFF	
*A2Hi	Alarm 2 High Setpoint Value	Setpoint Value or OFF	
A1Hy	Alarm 1 Hysteresis	Hysteresis Value in Measured Units	
*A2Hy	Alarm 2 Hysteresis	Hysteresis Value in Measured Units	
A1tt	Alarm 1 Trip Time	No of Seconds before Relay 1 trips	
*A2tt	Alarm 2 Trip Time	No of Seconds before Relay 2 trips	
A1n.o or A1n.c	Alarm 1 Action N/O or N/C	A1n.o or A1n.c	
*A2n.o or A2n.c	Alarm 2 Action N/O or N/C	A2n.o or A2n.c	
rEC_	Retransmission Output Low Limit	Value in Memory	
rEC	Retransmission Output High Limit	Value in Memory	
dLAY	Manual Ramping Delay Time	0 to 255 Seconds	
drnd	Display Rounding Selects Resolution	Value in Memory	
dCPt	Display Decimal Point	Decimal Pt Position (ie 000.1 or 00.02)	
FLtr	Digital Filter Range 0 to 8	0 to 8 (8=most filtering)	
CAL1	Calibration	See section on calibration	

Note: Functions (*shaded) shown on this table will be displayed, only when those particular

Auto/Manual Functions

There are several ways to change between auto and manual as follows:

Remote contact closure (see 1 below)

“inPt” set to “OFF”

External switch is open for Auto operation and closed for Manual

“inPt” set to “on”

External switch is closed for Auto operation and open for Manual operation.

“inPt” set to “togl”

Press momentary (normally open) pushbutton or remote contact connected to remote input to toggle between Auto and Manual.

Front panel keypads (see below)

Change between Auto and Manual by entering the function mode and selecting “Auto” or “LCAL” in the “Chng” (change) function.

1/ Changing between Auto and manual using a remote switch.

When the switch is operated the instrument will alternate between auto and manual. When changing from auto to manual, the manual value is matched to the auto value, creating a bumpless transfer - the front panel LED will indicate to “MAN”. When changing from manual to auto, the output will ramp towards the incoming auto value at a programmable rate (see “dLAY” function) - the front panel LED will indicate “AUTO”.

2/ Changing between Auto and Manual in the function mode.

(provided “inPt” is set to “togl”)

Enter the function mode by pressing the “F” button and then (within 2 seconds) press both the “|” and “⊕” pushbuttons simultaneously (as described in chapter “Explanation of Functions”). The display will indicate “Chng”, (indicating that the instrument may be changed between auto and manual).

Select between “Auto” (auto ie. direct transfer between input and output) and “LCAL” (local ie. manual mode). By pressing the “|” or “⊕” pushbuttons the display will toggle between “Auto” & “LCAL”. Pressing the “F” button will set the instrument to auto or manual. When changing from auto to manual, the manual value is set to the current auto value thus achieving a bumpless transfer function- the front panel LED will indicate “MAN”. When changing from manual to auto, the manual output will ramp to towards the auto value at a programmable rate (see “dLAY” function) - the front panel LED will indicate “AUTO”.

Notes:-

The manual output is set in the same manner as a function value (ie. alarms etc). Increment/decrement will start slowly then speed will increase while button is held. The retransmission output will update approximately 4 times per second.

Note that if the “F” button is pressed the “[” and “⊕” buttons will be disabled for 2 seconds to enable the normal function mode to be entered if required.

The manual output may only be set within the retransmission output limits, (ie if retransmission low is 400 and high is 2000 then the manual lower limit is 400 and the high limit 2000). NB if the retransmission is set as 2000 - 400 (reverse output !) then the lower limit is still 400 and the upper limit 2000.

When changing from manual to Auto mode the ramp rate is determined as followed:

$$\text{Change Time} = \left(\frac{\text{Auto Display Value} - \text{Manual Display Value}}{\text{Retransmission High} - \text{Retransmission Low}} \right) \times dLAY$$

If the input is over-ranged then the ramp rate approximates the maximum delay time. If the input changes and either reaches or overtakes the ramping value then the ramp is cancelled and normal operation resumes.

The alarms are triggered by the input value not the manual value.

When changing from Auto to manual the manual value is limited to the range specified above. ie, if the input is over-ranged high and the unit is switched to “LCAL” then the value displayed will be the retransmission high value.

Pressing the “P” button while in the manual mode will display the input value for 30 seconds. The display will flash “INPt” every 8 seconds as a reminder.

Calibration

To enter the calibration mode a special “power up procedure” must be followed. This procedure prevents accidental alteration of calibration and provides a degree of calibration security.

The unique calibration procedure allows for two calibration points to be independently set. This is useful where the calibration is being carried out on site and delays are experienced during the calibration procedure (i.e., filling tanks etc.).

Preparing to initialise

Turn off instrument Power.

Initialising the calibration mode

Press and hold the **F** button whilst applying power to the instrument. The instrument will momentarily show **CAL** (during the wake up messages) to let you know that the calibration level of the function mode is now accessible.

Entering the calibration mode

To enter the calibration mode, you must enter the function set up mode by pressing, then releasing **F** then, within 2 seconds, pressing, then releasing, **▲** and **▼** simultaneously. Step through the functions by pressing and releasing **F**, until the display indicates **CAL 1**.

Note: as you step through the functions take care not to accidentally alter the settings of the various functions.

Calibration (by applying an input signal)

Now press the **▲** and **▼** buttons simultaneously to enter the calibration mode. The display will now flash **CAL 1** (1st calibration point) every few seconds followed by the “live” reading. ***Apply a known input to the instrument of nominally 0% (this value is not critical and may be anywhere within the measuring range of the instrument). When the reading has stabilised press the **F** button.** The display will indicate **SEL 1** (scale 1) followed by the scale value in memory. Now press the **▲** or **▼** button to obtain the required scale (calibration) value. Press the **F** button the display will now indicate **CAL End**

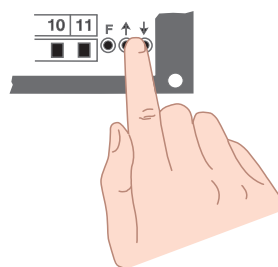

(indicating that calibration of the first point is complete). The display will now indicate **CAL 2** (2nd calibration point). Either step through the functions using the **F** button (to bypass the second calibration point) or enter the 2nd calibration mode as above by pressing the **▲** and **▼** buttons simultaneously. Apply an input of 100% (again this value is not critical, for best accuracy should not be too close to the previous value). When the reading has stabilised, press the **F** button, the display will now read **SCALE 2** (scale 2) followed by the second scale value in memory. Press the **▲** or **▼** button to obtain the required scale value. Press the **F** button the display will now read **CAL End** (indicating that calibration of the second point is complete). The display will return to the measure mode (with calibration access). Note: When entering the second point independently, the first calibration point may be bypassed, simply by pressing the **F** button instead of the **▲** and **▼** buttons simultaneously.

Offset Calibration

Sometimes it is necessary to make a single point adjustment to the calibration, it may be done using this function. Note the value set in this function will add or subtract the value equally across the measurement range of the instrument.

Enter the calibration mode as described above, but do not enter **CAL 1** or **CAL 2** setup functions. Step through the functions until the display indicates **OFFSE**, Now press the **▲** and **▼** buttons simultaneously to enter the offset mode. The display will now indicate **OFFSE** (offset) followed by the “live” reading. *Apply a known input to the instrument. When the reading has stabilised press the **F** button. The display will indicate **SCALE** (scale) followed by the value set in memory. Now press the **▲** or **▼** button to obtain the required offset. Press the **F** button the display will now indicate **OFFSE End** (indicating that the offset calibration is complete). The display will return to the measure mode (with calibration access).

Input Scaling (By keying in scaling values)[4 to 20mA only]



The instrument may be calibrated without using test equipment, by setting the known values for 4 and 20 mA. To enter this mode, follow the procedure described above. Bypass the **CAL 1**, **CAL 2** and **OFFSE** functions by pressing the **F** button. The display will now indicate **SCALE** (input scaling) press the



▲ and **▼** buttons simultaneously. The display will now indicate **En 4** (enter 4 mA scaling value) followed by the last scaling value in memory. Using the **▲** or **▼** button set the display to the required reading for 4mA. Now press the **F** button. The display will indicate **En 20** (enter 20 mA scaling value) followed by the last scale value in memory. Now press the **▲** or **▼** button to obtain the required reading for 20 mA. Press **F** button the display will now

read **CAL End** indicating that the calibration/scaling is complete. The display will return to the measure mode (with calibration access).

Uncalibration

The uncalibration function sets the instrument back to the factory calibration value. This function is useful as a temporary measure when the input source device/transmitter is replaced and on the spot recalibration is difficult or when a calibrating error exists due to a problem during calibration. The uncalibration mode follows the calibration mode described above and is initialised by pressing the  and  buttons simultaneously (note this function will delete the existing calibration and should only be used when necessary). The display will show **CAL CLR** indicating that the calibration is cleared. The display will return to the measure mode (with calibration access).

Returning to the normal measure mode

Turn off power to the instrument (to exit the calibration access mode), wait a few seconds and then restore power.

Note:

* “Apply a known input” refers to either a simulated or real input. Since the PM4 is intended for use with various transducers, the input may take the form of a weight (weighing applications), an air or hydraulic pressure input (pressure transducers), temperature (temperature transmitters with 4 to 20 mA outputs) or a suitable electronic simulator etc.

Hardware Configuration

Selecting the input range

Dismantle the instrument as described in section titled Input/output Configuration. Insert the links into the appropriate location on the pin header, to suit the range required.

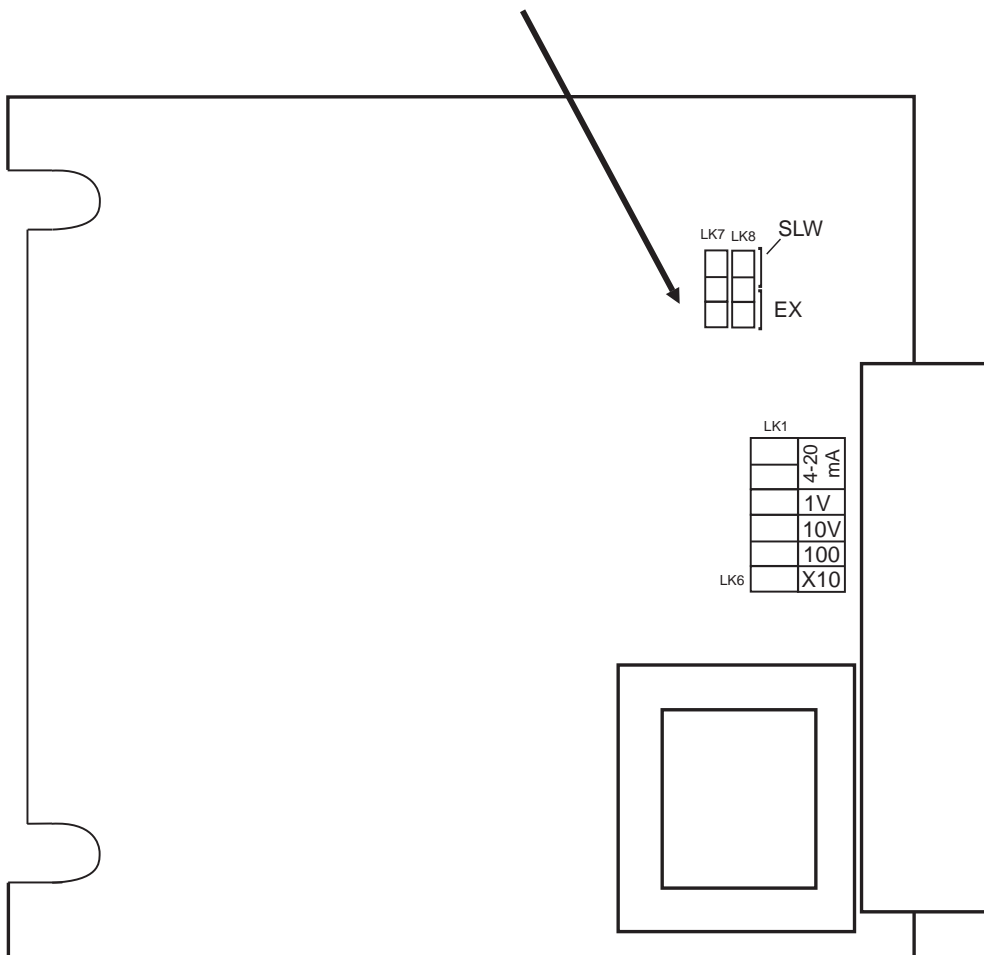
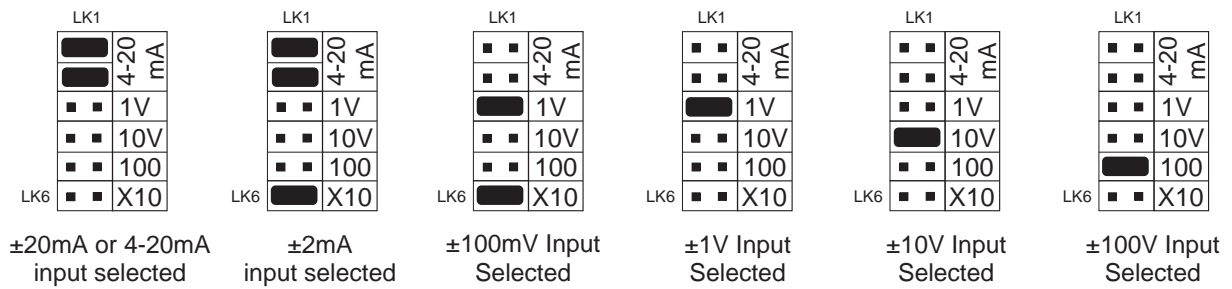

Main Circuit Board

Configuring the output board

The optional output board is factory supplied with the necessary components for the output options required. Combinations of three output types are available:

- a/ 2nd relay output
- b/ Isolated analog retransmission (4-20mA, 0-1V or 0-10V)
- c/ Isolated DC Voltage output (to power transmitters etc)

PCB links are fitted to the circuit board to provide data to the microprocessor and to connect the electronic components for the correct output types. It may be necessary to alter the PCB links to change the analog output or the DC voltage output (see tables below) (to dismantle the instrument, see section titled "Input/output configuration") .

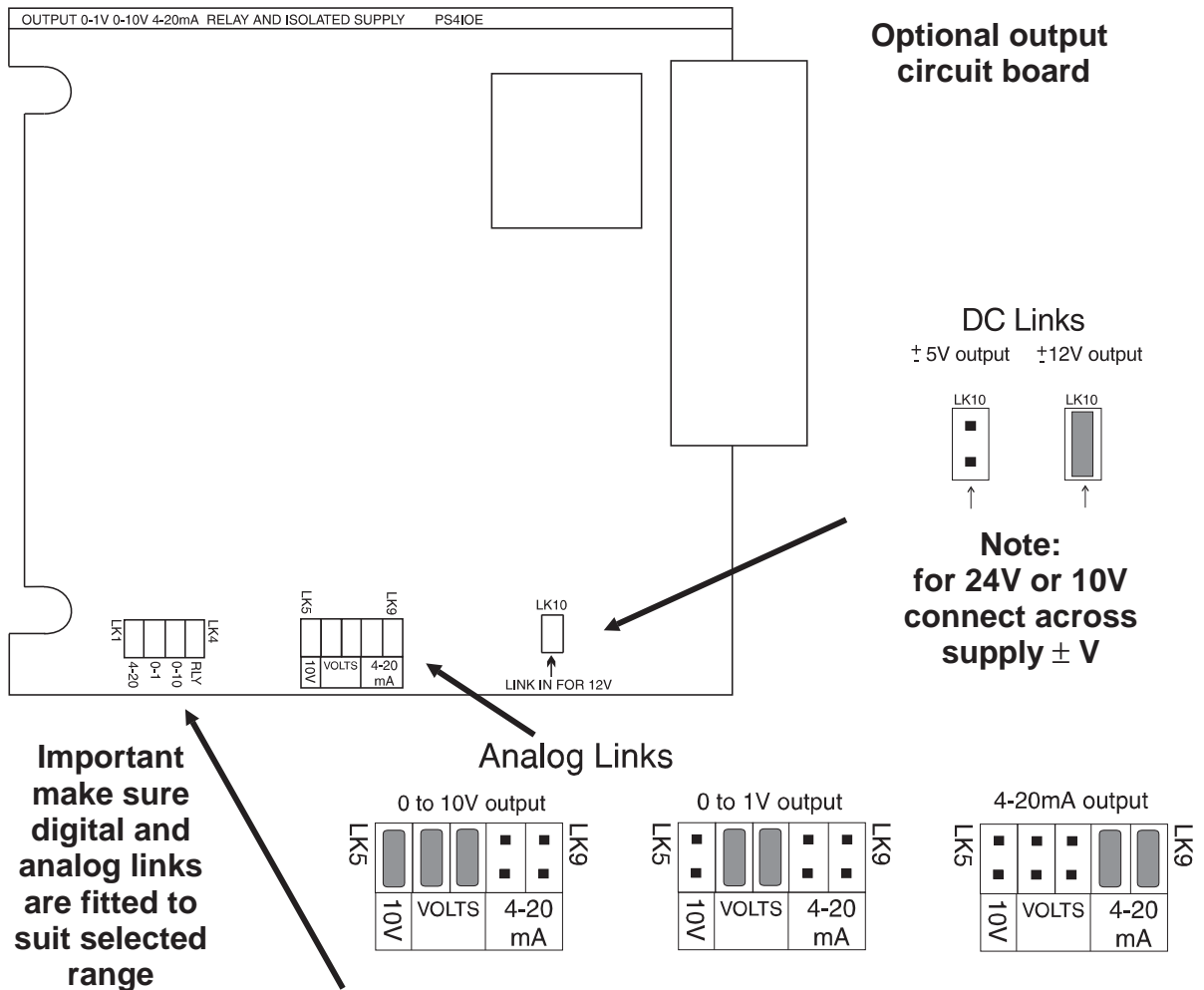

Specifications

14 .1 Technical Specifications

Input Types:	Link selectable 4 to 20mA or DC Volts -2 to 2V, -20 to 20V, -100 to 100V
Impedance:	80Ω (4 to 20mA) & 1MΩ on DC Voltage
ADC Resolution:	1 in 20,000
Accuracy:	0.1% when calibrated
Sample Rate:	4 per sec
Conversion Method:	Dual Slope ADC
Microprocessor:	MC68HC05C8 CMOS
Ambient Temperature:	-40 to 60°C
Humidity:	5 to 95% non condensing
Display:	5 digit 14.2mm + status LEDs + 4 way keypad.
Power Supply:	AC 240V, 110V or 24V 50/60Hz DC 9 to 55V
Power Consumption:	AC supply 4 VA max, DC supply, consult AIC (depends on display type & options)
Output (standard):	1 x relay, Form, A rated 5A resistive
Relay Action:	Programmable N.O. or N.C.
Analog Retransmission:	4 to 20mA standard 0 to 1V and 0 to 10V link selectable

14 .2 Output Options

2nd Relay:	Same specs as Relay 1
DC Voltage Output:	Isolated ±12V(24V) standard, ±5V(10V) link selectable.

14 .3 Physical Characteristics

Bezel Size:	DIN 48mm x 96mm x 10mm
Case Size:	44mm x 91mm x 120mm behind face of panel
Panel Cut Out:	45mm x 92mm +1mm &- 0mm
Connections:	Plug in screw terminals (max 1.5mm wire)
Weight:	400 gms Basic model, 450 gms with option card