

**Model PM4-IVT
Process Rate/Total Monitor
Panel Mount Display/Controller
Operation and Instruction Manual**

AMALGAMATED INSTRUMENT CO

Unit 5, 28 Leighton Place Hornsby
NSW 2077 Australia

Telephone: +61 2 9476 2244
Facsimile: +61 2 9476 2902

ABN: 80 619 963 692

e-mail: sales@aicpl.com.au
Internet: www.aicpl.com.au



Table of Contents

1	Introduction	3
2	Mechanical Installation	4
3	Electrical installation	5
4	Function tables - summary of setup functions	11
5	Explanation of functions	16
6	Calibration	40
7	Specifications	44
8	Guarantee and service	45

1 Introduction

1.1 General description

This manual contains information for the installation and operation of the PM4-IVT rate/total monitor. The PM4-IVT is a general purpose instrument which may be configured to accept an input signal of $\pm 2\text{mA}$, $\pm 20\text{mA}$, 4 to 20mA, $\pm 100\text{mV}$, $\pm 1\text{V}$, $\pm 10\text{V}$, $\pm 100\text{VDC}$ or 3 wire slidewire ($0\text{-}1\text{k}\Omega$ to $0\text{-}1\text{M}\Omega$).

The display can toggled between rate and total display via the  or  pushbuttons or via a remote switch input. The total can be reset by programming either the  button (if fitted on display type used) or the remote input (terminals 7 and 8) to clear the total, see **P.but** and **CLRP** functions. Alternatively the total can be reset at the **CLR tot** function. Unless the display has been programmed to automatically reset to zero (see **tot: RAP.F** function) at full display scale reading e.g. **99999** the display will show the message **-or-** when the total is too large to display, when this message is seen the total will need to be reset before totalising operations can be resumed. The instrument may be calibrated to display the input in engineering units.

The PM4 series of Panel Mount Monitors are designed for high reliability in industrial applications. The high brightness LED display provides good visibility even in areas with high ambient light levels. The high contrast LCD displays provide good visibility and are ideal for battery powered applications. Full electrical isolation between power supply, input voltage or current and retransmission output is provided by the PM4, thereby eliminating grounding and common voltage problems. This isolation feature makes the PM4 ideal for interfacing to computers, PLCs and other data acquisition devices. Unless otherwise specified at the time of order, your PM4 has been factory set to a standard configuration. The PM4 series instruments can be configuration and calibrated easily by the user. Initial changes may require dismantling the instrument to alter PCB links, other changes are made by push button functions.

1.2 Standard outputs

- A standard inbuilt relay provides an alarm or on/off control function.
- A non isolated transmitter supply of approx. 18VDC (25mA max.) regulated is provided.

1.3 Output options

- 1, 3 or 6 extra relays
- Isolated analog retransmission (single or dual analog outputs) configurable for 4–20mA, 0–1V or 0–10V, configurable for retransmission or PI control
- $\pm 12\text{VDC}$ (24V) isolated transmitter supply/excitation voltage (25mA max.). Not to be used at the same time as the standard 18VDC unregulated transmitter supply
- Isolated RS485 or RS232 serial communications (ASCII or Modbus RTU)
- Isolated Digital output - binary or BCD up to 16 bit, NPN or PNP output types available
- Isolated Optional outputs are available in certain combinations e.g. Extra relay plus RS232

2 Mechanical Installation

Choose a mounting position as far away as possible from sources of electrical noise such as motors, generators, fluorescent lights, high voltage cables/bus bars etc. An IP65 or IP67 access cover which may be installed on the panel and surrounds is available as an option to be used when mounting the instrument in damp/dusty positions. A wall mount case is available, as an option, for situations in which panel mounting is either not available or not appropriate. A portable carry case is also available, as an option, for panel mount instruments.

Prepare a panel cut out of 45mm x 92mm +1 mm / - 0 mm (see diagram below). Insert the instrument into the cut out from the front of the panel. From the rear of the instrument fit the two mounting brackets into the recess provided (see diagram below). Whilst holding the bracket in place, tighten the securing screws being careful not to over-tighten, as this may damage the instrument. Hint: use the elastic band provided to hold the mounting bracket in place whilst tightening securing screws.

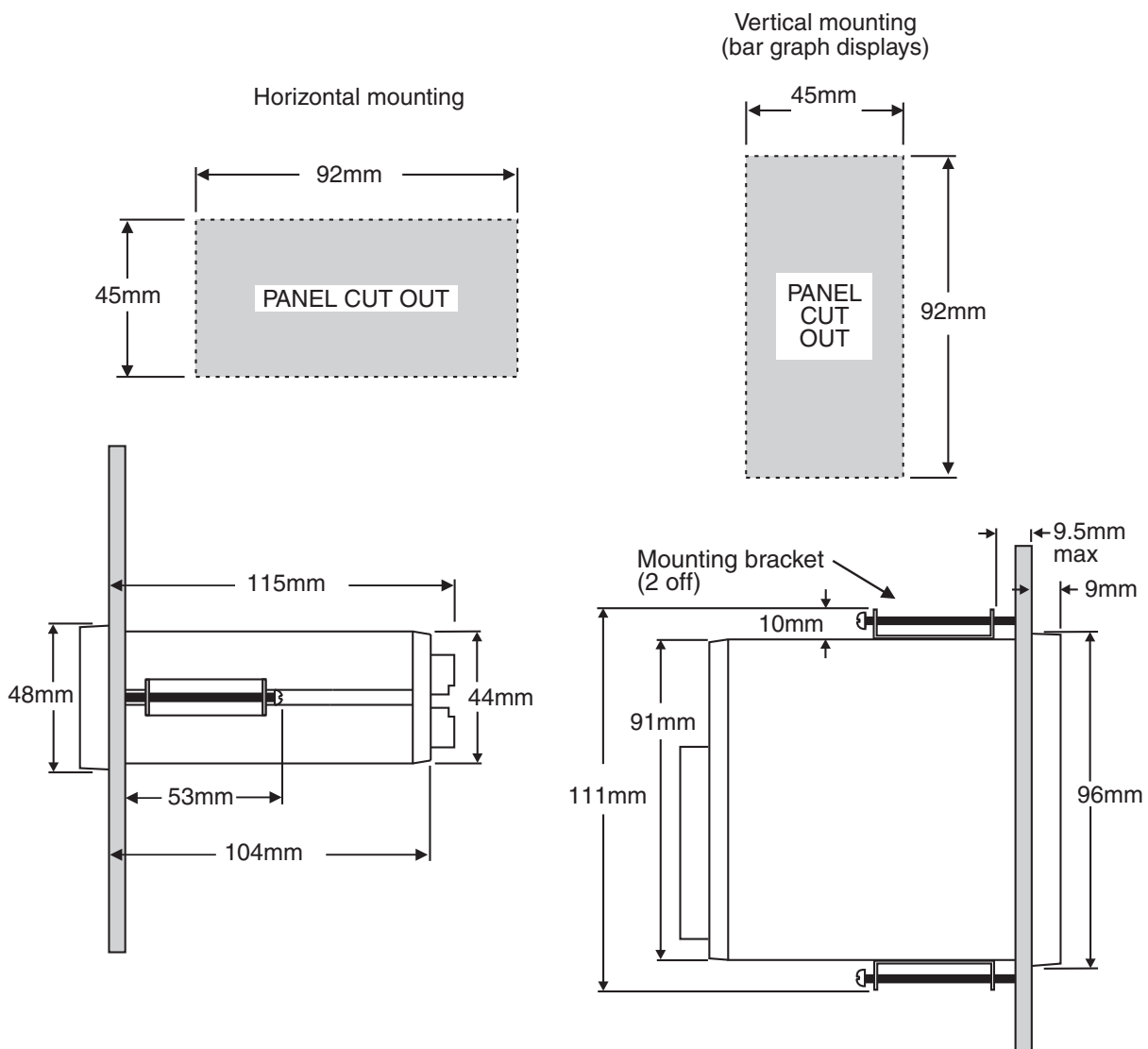

3 Electrical installation

3.1 Electrical installation

The PM4 Panel Meter is designed for continuous operation and no power switch is fitted to the unit. It is recommended that an external switch and fuse be provided to allow the unit to be removed for servicing.

The plug in, screw type, terminal blocks allow for wires of up to 2.5mm² to be fitted. Connect the wires to the appropriate terminals as indicated below. Refer to connection details provided in this chapter to confirm proper selection of voltage, polarity and input type before applying power to the instrument.

When power is applied the instrument will cycle through a display sequence indicating the software version and other status information, this indicates that the instrument is functioning. Acknowledgement of correct operation may be obtained by applying an appropriate input to the instrument and observing the reading. The use of screened cable is recommended for signal inputs.

For connection details of optional outputs refer to the separate "PM4 Panel Meter Optional Output Addendum" booklet supplied when options are fitted.

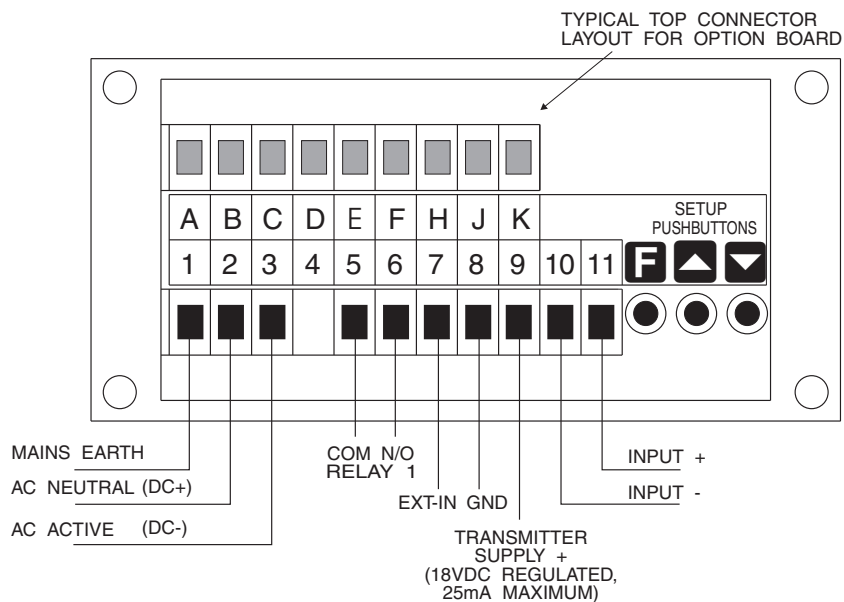

1	MAINS EARTH	
2	240VAC NEUTRAL	
3	240VAC ACTIVE	
5	RELAY 1	COM
6	RELAY 1	N/O
7	EXT IN	
8	GND	
9	SUPPLY	+18VDC
10	INPUT	-VE
11	INPUT	+VE
PM4-IVT-240-5E		SERIAL No.

Instrument data label (example)

3.2 Electrical connection examples

If output options are fitted refer to the "PM4 Panel Meter Optional Output Addendum" booklet for connection details.

AC power connections - supply type is factory configured, check before connecting

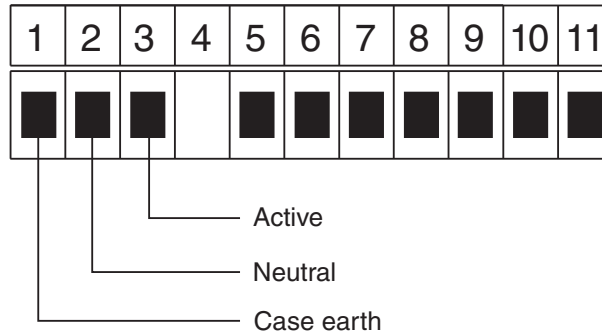

DC power connections (12 to 48VDC) - supply type is factory configured, check before connecting

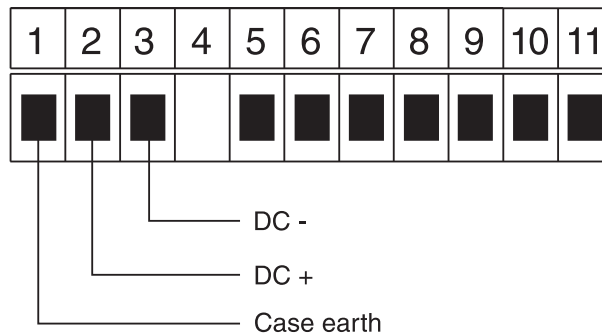

2 wire 4-20mA powered from non isolated regulated 18V supply (25mA maximum)

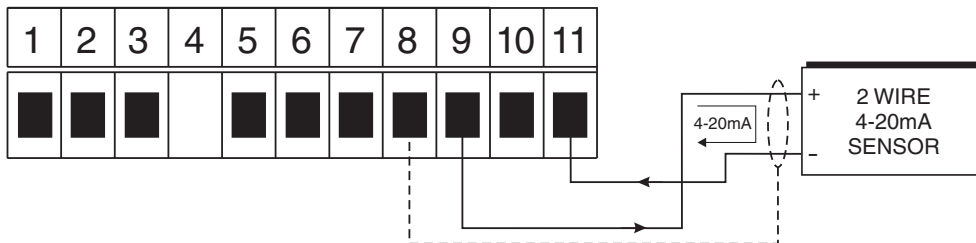

2 wire 4-20mA externally powered sensor

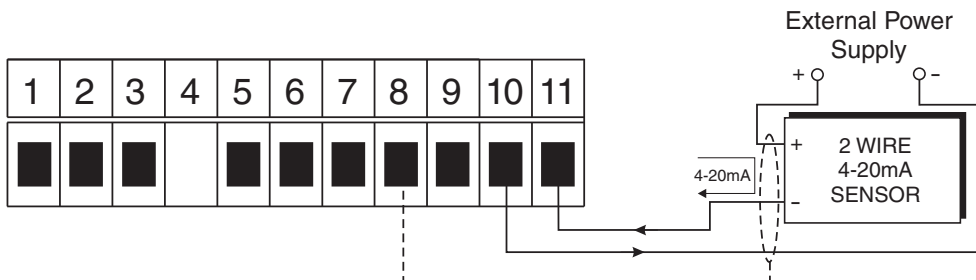

3 wire 4-20mA externally powered sensor

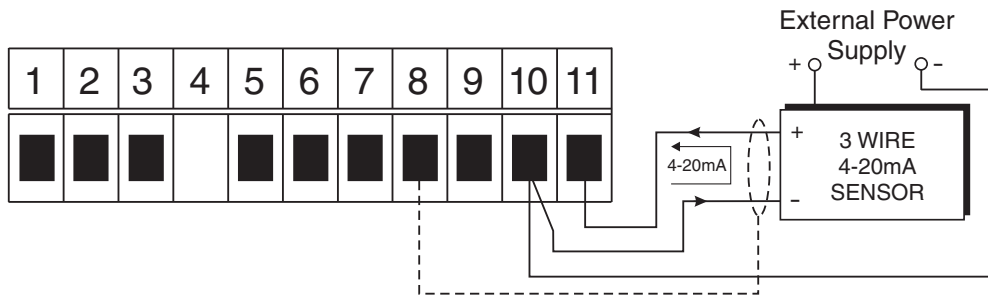

4 wire 4-20mA externally powered sensor

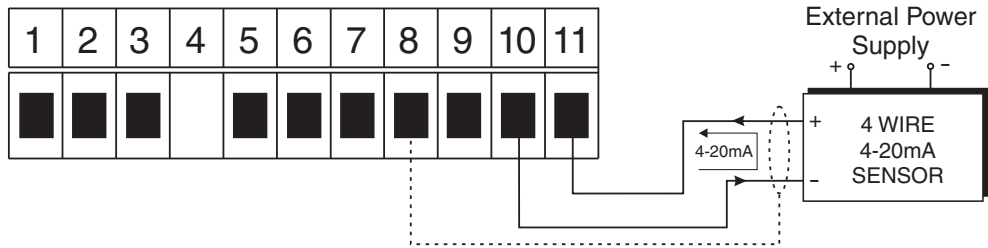

3 wire 4-20mA powered from non isolated regulated 18V supply (25mA maximum)

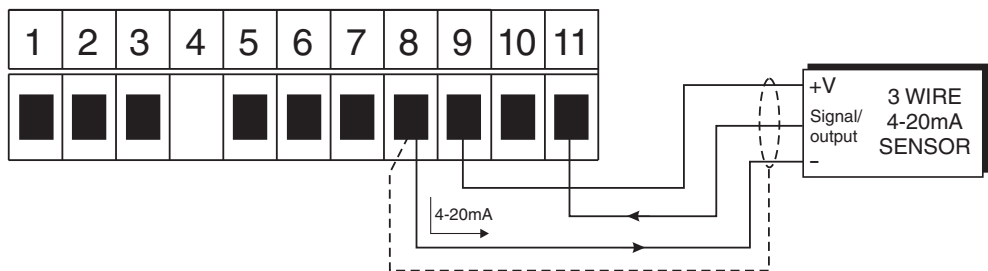

2 wire 4-20mA powered from optional isolated regulated 24V (± 12V) supply (25mA maximum)

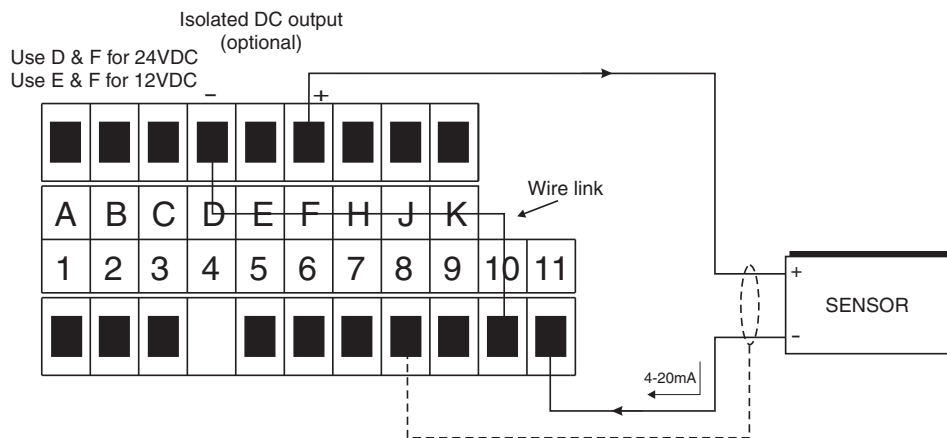

DC voltage input

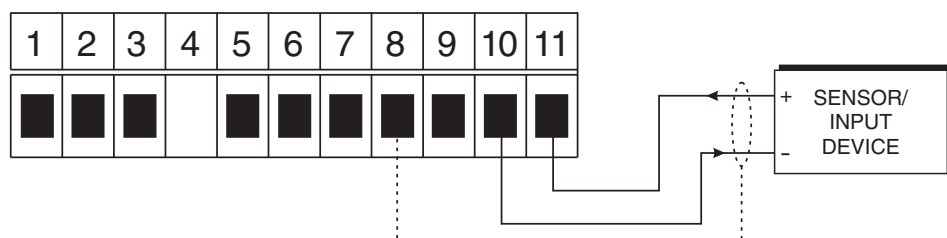

Slidewire input

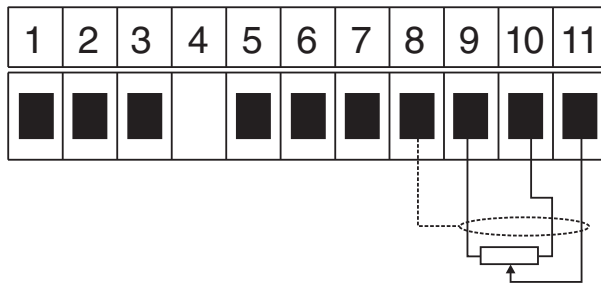

Note: Links LK7 & LK8 Must be set to SLIDE WIRE for Slide Wire input all other links should be out.

Remote input

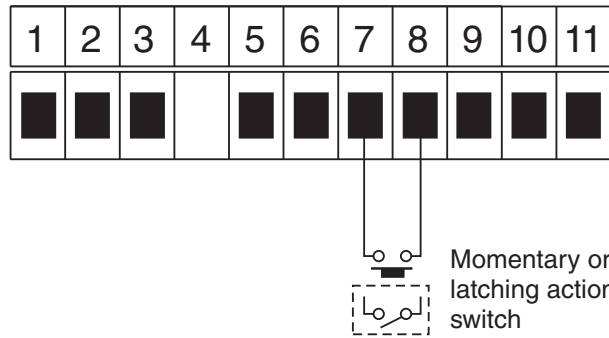

Momentary or latching action switch

3.3 Input Output Configuration

If you need to alter the input or output configuration link settings proceed as follows:

1. Remove the plug in terminals from the rear of the instrument

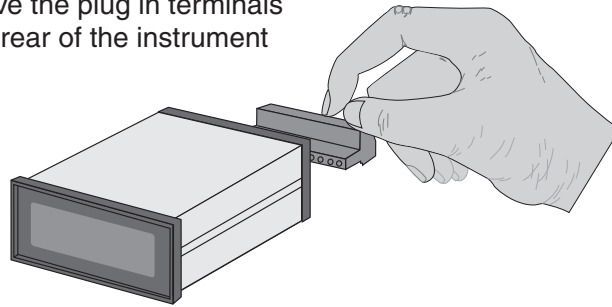

2. Remove the 4 x self tapping screws from the back cover then remove the back cover by pulling it away from the instrument

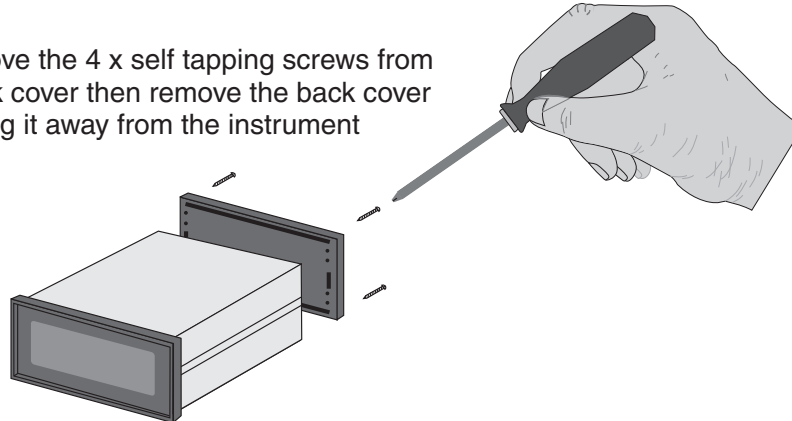

3. Remove the earth screw which passes through the underside of the case then slide out the board or boards

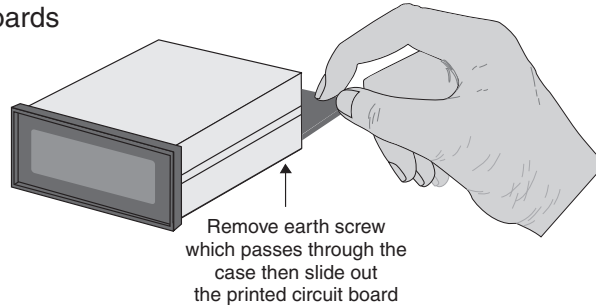

4. Configure the PCB links as required, see appropriate chapter
5. Slide PCB back into case
6. Replace the earth screw which passes through the case
7. Refit the back cover and fix with the self tapping screws
8. Plug the terminal strips back into the rear of the instrument

4 Function tables - summary of setup functions

Note: the order in which the functions appear on the display may not be exactly as shown below. The availability and order of functions is determined by choice of function settings and options fitted.

Functions in this first table are available in **FUNC** or **CAL** mode

Display	Function	Range	Default	Your record	Ref/Page
RxPS	Relay pass value	Any display value	OFF	See 4.1	5.1 / 18
RxPt	Relay pass time	0.0 to 999.9	0.0	See 4.1	5.2 / 18
RxLo	Low setpoint value for designated alarm relay <i>x</i>	Any display value or OFF	OFF	See 4.1	5.3 / 18
RxHi	High setpoint value for designated alarm relay <i>x</i>	Any display value or OFF	OFF	See 4.1	5.4 / 19
RxHY	Hysteresis value for the designated alarm relay <i>x</i> .	0 to 9999	10	See 4.1	5.5 / 20
Rxtt	Trip time delay for the designated alarm relay <i>x</i> .	0 to 9999	0	See 4.1	5.6 / 20
Rxrt	Reset time delay for the designated alarm relay <i>x</i> .	0 to 9999	0	See 4.1	5.7 / 21
Rxn.o or Rxn.c	Alarm relay <i>x</i> action to normally open (de-energised) or normally closed (energised)	Rxn.o or Rxn.c	Rxn.o	See 4.1	5.8 / 21
RxSP or Rxt 1 etc.	Relay operation independent setpoint or trailing setpoint (*Optional)	RxSP or Rxt 1 etc.	RxSP	See 4.1	5.9 / 21
brgt	Display brightness level	1 to 15	15		5.10 / 22
dull	Display remote brightness switching	0 to 15	1		5.11 / 22

(*Optional)—this function will only be accessible if the relevant option is fitted

Functions in this second table are available only in **CAL** mode or if **ACCS** is set to **ALL**

Display	Function	Range	Default	Your record	Ref/Page
bAr₋	Bargraph low value (seen only on bargraph display instruments)	Any display value	0		5.12 / 22
bAr⁺	Bargraph high value (seen only on bargraph display instruments)	Any display value	1000		5.13 / 23
bAr tYPE	Bargraph type for instruments with bargraph display (seen only on bargraph display instruments)	bAr , 5.dot , d.dot , C.bAr or r.dot	bAr		5.14 / 23
d9OP	Digital output option mode (*Optional)	bcd , b.SCL , b, n or b, n2	b, n2		5.15 / 24
d9.OP	Digital output option polarity (*Optional)	RI 0 or RI 1	RI 0		5.16 / 24
bcd StArt	Digital output option BCD start position (*Optional)	0 , 1 or 2	0		5.17 / 24
d, 9₋	Digital output option low value (*Optional)	Any display value	0		5.18 / 25
d, 9⁺	Digital output option high value (*Optional)	Any display value	1000		5.19 / 25
fEC₋	Analog output option low display value (*Optional)	Any display value	0		5.20 / 25
fEC⁺	Analog output option high display value (*Optional)	Any display value	1000		5.21 / 25
fEC₋ Ch2	Second analog output option low display value (*Optional)	Any display value	0		5.22 / 26
fEC⁺ Ch2	Second analog output option high display value (*Optional)	Any display value	1000		5.23 / 26
dRnd	Display rounding	1 to 5000	1		5.24 / 26
dCPt	Decimal point	0 , 0.1 etc.	0		5.25 / 26
FLtR	Digital filter	0 to 8	2		5.26 / 27
rEc cTrl	Analog output PI control (*Optional)	on or OFF	OFF		5.27 / 27
CAL 1	First live input calibration scaling point	Any display value	n/a		5.28 / 27
CAL 2	Second live input calibration scaling point	Any display value	n/a		5.29 / 28
CAL OFFSet	Calibration offset	Any display value	n/a		5.30 / 28
ZEFO RNGE	Zero range limit	Any display value or OFF	OFF		5.31 / 28

(*Optional)—this function will only be accessible if the relevant option is fitted

CAL ZERO	Zero reference point for ZERO RANGE operation	n/a	n/a		5.32 / 28
USER EN4	4mA input scale	Any display value	n/a		5.33 / 28
USER EN20	20mA input scale	Any display value	n/a		5.34 / 29
UCAL	Uncalibrate	n/a	n/a		5.35 / 29
Pbut	P button function (for instruments with front P button)	NONE.H. Lo.H.Lo. ZERO.di SP, or CLF.t	NONE		5.36 / 29
R.I NP	Remote input (external input) function	NONE. P.Hld. d.Hld.H. Lo.H.Lo. ZERO. SP.Ac. No.Ac. CAL.S. dULL.di SP or CLF.t	NONE		5.37 / 29
ACCESS	Access mode	OFF.EASY. NONE or ALL	OFF		5.38 / 31
SPAC	Setpoint access mode (*Optional)	R1.R1-2 etc.	R1		5.39 / 31
SQRt	Square root mode	on or OFF	OFF		5.40 / 31
totl dCPl	Total display decimal point selection	0 to number of display digits minus 1	0		5.41 / 32
di SP SCLE	Total display scaling factor	Any display value	1		5.42 / 32
totl SECS	Totaliser scaling factor	Any display value	50		5.43 / 32
E.SCL	Total exponent scaling factor	0 to 9	0		5.44 / 33
totl NEG	Negative total select	OFF or on	OFF		5.45 / 34
totl RAP.F	Wrap around operation	ZERO or STOP	ZERO		5.46 / 34
CLF totl	Clear total	n/a	n/a		5.47 / 34
dfi t di SP	Default display	RAtE or totl	RAtE		5.48 / 35

(*Optional)—this function will only be accessible if the relevant option is fitted

Ax.rE, Ax.tL or Ax.PS	Alarm relay 1 operation mode	Ax.rE, Ax.tL or Ax.PS	Ax.rE		5.49 / 35
bAR	Bargraph display operation mode	rRE or totL	rRE		5.50 / 35
rEC	Analog operation mode (*Optional)	L, uE, totL, P.HLd, d.HLd.H, . Lo or dI SP	L, uE		5.51 / 35
d9.OP	Digital output operation mode (*Optional)	rRE or totL	rRE		5.52 / 36
Lo dI SP	Low overrange visual warning limit value	Any display value or OFF	OFF		5.53 / 36
Hi 9H dI SP	High overrange visual warning limit value	Any display value or OFF	OFF		5.54 / 36
dI SP	Display visual warning flashing mode	FLSH or -or-	FLSH		5.55 / 37
bAUD rRE	Baud rate for serial communications (*Optional)	300.600. 1200.2400. 4800.9600. 19.2 or 38.4	9600		5.56 / 37
Prty	Parity for serial communications (*Optional)	NONE.EVEN or odd	NONE		5.57 / 37
O.PuE	Output for serial communications (*Optional)	dI SP.Cont. POLL, A.buS or ā.buS	Cont		5.58 / 38
Addr	Instrument address for serial communications (*Optional)	0 to 31	0		5.59 / 38
SEFL	Serial mode for serial communications (*Optional)	L, uE, totL, P.HLd, d.HLd.H, . Lo.H, Lo or both	L, uE		5.60 / 38

(*Optional)—this function will only be accessible if the relevant option is fitted

4.1 Relay table

Record your relay settings in the table below

Display	Relay 1	Relay 2	Relay 3	Relay 4	Relay 5	Relay 6	Relay 7
<i>AxPS</i>							
<i>AxPt</i>							
<i>AxLo</i>							
<i>AxHi</i>							
<i>AxHY</i>							
<i>Axtt</i>							
<i>Axrt</i>							
<i>Axn.o</i> or <i>Axn.c</i>							
<i>AxSP</i> or <i>Axt i</i> etc.	n/a						
<i>Ax.rt</i>, <i>Ax.tL</i> or <i>Ax.PS</i>							

5 Explanation of functions

The PM4 setup and calibration functions are configured through a push button sequence. The three push buttons located at the rear of the instrument (also at the front on some display options) are used to alter settings. Two basic access modes are available:

FUNC mode (simple push button sequence) allows access to commonly set up functions such as alarm setpoints.

CAL mode (power up sequence plus push button sequence) allows access to all functions including calibration parameters.

Once **CAL** or **FUNC** mode has been entered you can step through the functions, by pressing and releasing the **F** push button, until the required function is reached. Changes to functions are made by pressing the or push button (in some cases both simultaneously) when the required function is reached. See the flow chart example on the following page.

Entering **CAL** Mode



1. Remove power from the instrument. Hold in the **F** button and reapply power. The display will briefly indicate **CAL** as part of the "wake up messages" when the **CAL** message is seen you can release the button. Move to step 2 below.



2. When the "wake up" messages have finished and the display has settled down to its normal reading press, then release the **F** button. Move to step 3 below.

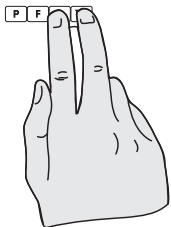

3. Within 2 seconds of releasing the **F** button press, then release the **▲** and **▼** buttons together. The display will now indicate **FUNC** followed by the first function.

Note: If step 1 above has been completed then the instrument will remain in this **CAL** mode state until power is removed. i.e. there is no need to repeat step 1 when accessing function unless power has been removed.

Entering **FUNC** Mode

No special power up procedure is required to enter **FUNC** mode.



1. When the "wake up" messages have finished and the display has settled down to its normal reading press, then release the **F** button.

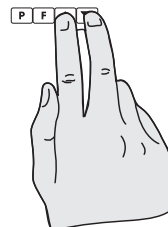

2. Within 2 seconds of releasing the **F** button press, then release the **▲** and **▼** buttons together. The display will now indicate **FUNC** followed by the first function.

Example: Entering **FUNC** mode to change alarm 1 high function **A 1H**, from **OFF** to **100**

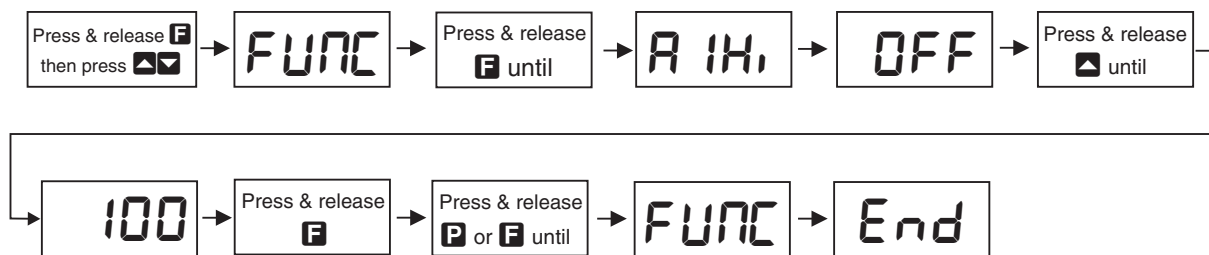

Example: Entering **CAL** mode to change decimal point function **dCPT** from **0** to **0.02**

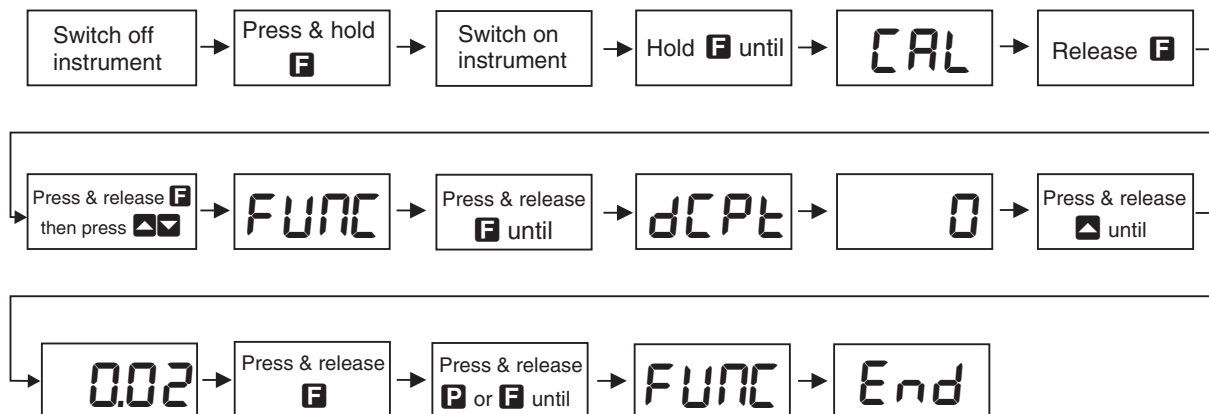

Easy alarm relay adjustment access facility

The display has an easy alarm access facility which allows access to the alarm setpoints simply by pressing the **F** button at the front or rear of the instrument. The first setpoint will then appear and changes to this setpoint may be made to this setpoint via the **▲** or **▼** buttons. Press the **F** button to accept any changes or to move on to the next setpoint. Note: this easy access also functions in the same manner for the PI control setpoint (relay and/or analog PI output) if PI control is available. The instrument must be set in the manner described below to allow the easy access facility to work:

1. The **FN** function must be set to **SPAC** or the **ACCS** function must be set to **EASY**.
2. At least one alarm must have a setpoint, nothing will happen if all the alarm setpoints are set to **OFF**.
3. The **SPAC** function must be set to allow access to the relays required e.g. if set to **A 1-2** then the easy access will work only with alarm relays 1 and 2 even if more relays are fitted.
4. The instrument must be in normal measure mode i.e. if the instrument is powered up so that it is in **CAL** mode then the easy access will not function. If in doubt remove power from the instrument, wait for a few seconds then apply power again.
5. If the easy access facility is used then the only way to view or alter any other function settings is to power up via **CAL** mode i.e. there is no entry to **FUNC** mode functions unless the instrument is powered up in **CAL** mode.

Explanation of Functions

5.1 Relay pass value

Display: ***RxPS***
Range: Any display value
Default Value: ***OFF***

Alarm relay pass value - only seen when ***RxPS*** is selected at the ***Rxrt/RxtL/RxPS*** function. Displays and sets the chosen alarm relay (***R1Pt, R2Pt*** etc.) pass time in seconds. The alarm relay will activate at multiples of the pass value e.g. if ***R1PS*** is set to ***50*** then relay 1 will activate at a total display value of ***50, 100, 150*** etc. The time for which the relay remains activated at each pass value is set via the ***RxPt*** function which follows. The pass value may be set anywhere in the display range of the instrument, positive or negative. The pass value can be set to ***OFF*** (disabled) by pressing the **▲** and **▼** buttons together.

5.2 Relay pass time

Display: ***RxPt***
Range: ***0.0*** to ***999.9***
Default Value: ***0.0***

Alarm relay pass time - only seen when ***RxPS*** selected at the ***Rxrt/RxtL/RxPS*** function. Displays and sets the chosen alarm relay (***R1Pt, R2Pt*** etc.) pass time in seconds. The value set is the time for which the relay will remain energised when activated at a pass value. e.g. if set to ***2.0*** with a ***R1PS*** value of ***50*** then the relay will remain energised for ***2.0*** seconds every time the display passes a multiple of ***50***. Note: If the pass time exceeds the time taken to reach consecutive pass values then the instrument will “store” any relay operations it does not have time to activate and will perform these activations when the total display update rate allows. For this reason the relay may be seen to activate repeatedly for a period after the total update rate has slowed down or stopped.

5.3 Alarm relay low setpoint

Display: ***RxLo***
Range: Any display value or ***OFF***
Default Value: ***OFF***

Displays and sets the low setpoint value for the designated alarm relay *x*. Note *x* will be replaced by the relay number when displayed e.g. ***R1Lo*** for relay 1. Use this low setpoint function if a relay operation is required when the display value becomes equal to or less than the low setpoint value. To set a low alarm value go to the ***RxLo*** function and use the **▲** or **▼** push buttons to set the value required then press **F** to accept this value. The low alarm setpoint may be disabled by pressing the **▲** and **▼** push buttons simultaneously. When the alarm is disabled the display will indicate ***OFF***. If the relay is allocated both a low and high setpoint then the relay will activate when the value displayed moves outside the band set by the low and high setpoints. The value at which the relay will reset is controlled by the ***RxHy*** function.

Example:

If **RxLo** is set to **10** then relay 1 will activate when the display value is 10 or less.

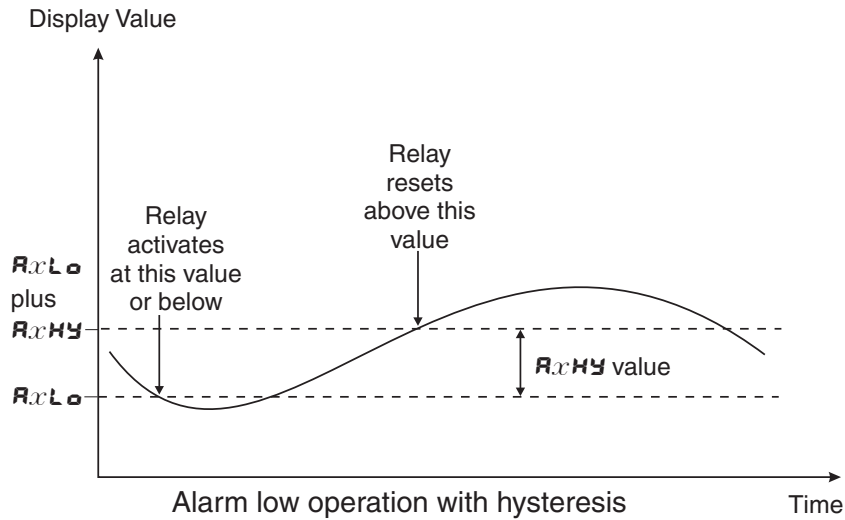

5.4 Alarm relay high setpoint

- Display: **RxH**
- Range: Any display value or **OFF**
- Default Value: **OFF**

Displays and sets the high setpoint value for the designated alarm relay *x*. Note *x* will be replaced by the relay number when displayed e.g. **R1H**, for relay 1. Use this high setpoint function if a relay operation is required when the display value becomes equal to or more than the low setpoint value. To set a high alarm value go to the **RxH** function and use the **▲** or **▼** push buttons to set the value required then press **F** to accept this value. The high alarm setpoint may be disabled by pressing the **▲** and **▼** push buttons simultaneously. When the alarm is disabled the display will indicate **OFF**. If the relay is allocated both a low and high setpoint then the relay will activate when the value displayed moves outside the band set by the low and high setpoints. The value at which the relay will reset is controlled by the **RxHy** function.

Example:

If **R1H** is set to **100** then relay 1 will activate when the display value is **100** or higher.

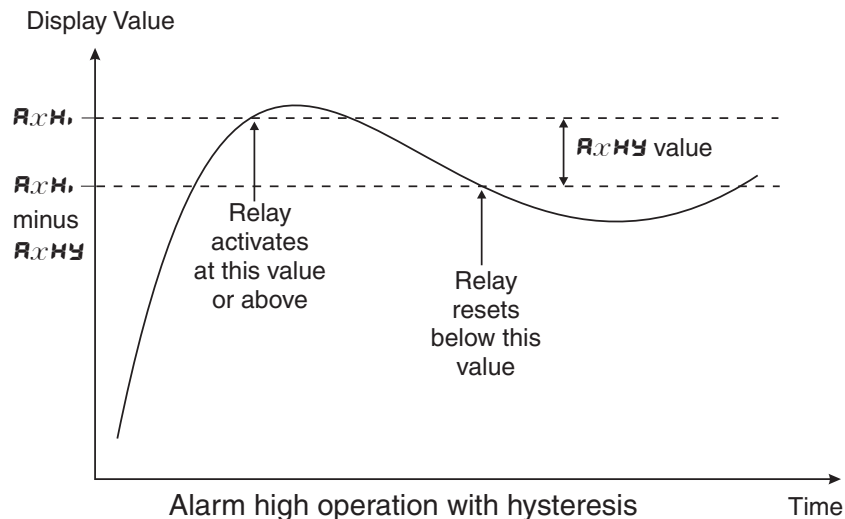

5.5 Alarm relay hysteresis (deadband)

Display: **RxHY**
Range: **0** to **9999**
Default Value: **10**

Displays and sets the alarm relay hysteresis limit for the designated relay x . Note x will be replaced by the relay number when displayed e.g. **R 1HY** for relay 1. To set a relay hysteresis value go to the **RxHY** function and use the **▲** or **▼** push buttons to set the value required then press **F** to accept this value. The hysteresis value is common to both high and low setpoint values. The hysteresis value may be used to prevent too frequent operation of the relay when the measured value is rising and falling around setpoint value. e.g. if **R 1HY** is set to zero the alarm will activate when the display value reaches the alarm setpoint (for high alarm) and will reset when the display value falls below the setpoint, this can result in repeated on/off switching of the relay at around the setpoint value.

The hysteresis setting operates as follows: In the high alarm mode, once the alarm is activated the input must fall below the setpoint value minus the hysteresis value to reset the alarm. e.g. if **R 1H** is set to **50.0** and **R 1HY** is set to **3.0** then the setpoint output relay will activate once the display value goes to **50.0** or above and will reset when the display value goes below **47.0** i.e. at **46.9** or below. In the low alarm mode, once the alarm is activated the input must rise above the setpoint value plus the hysteresis value to reset the alarm. e.g. if **R 1L** is to **20.0** and **R 1HY** is set to **10.0** then the alarm output relay will activate when the display value falls to **20.0** or below and will reset when the display value goes above **30.0** i.e. at **30.1** or above. The hysteresis units are expressed in displayed engineering units.

Example: If **R 1H** is set to **100** and **R 1HY** is set to **10** then relay 1 will activate when the display value is **100** or higher and will reset at a display value of **89** or lower.

5.6 Alarm relay trip time

Display: **RxTT**
Range: **0** to **9999**
Default Value: **0**

Displays and sets the alarm trip time in seconds. The trip time is common for both alarm high and low setpoint values. The trip time provides a time delay before the alarm relay will activate when an alarm condition is present. The alarm condition must be present continuously for the whole trip time period before the alarm will activate. If the input moves out of alarm condition during this period the timer will reset and the full time delay will be restored. This trip time delay is useful for preventing an alarm trip due to short non critical deviations from setpoint. The trip time is selectable over **0** to **9999** seconds. To set a trip time value go to the **RxTT** function and use the **▲** or **▼** push buttons to set the value required then press **F** to accept this value.

Example: If **R 1TT** is set to **5** seconds then the display must indicate an alarm value for a full 5 seconds before relay 1 will activate.

5.7 Alarm relay reset time

Display: ***R_xr_t***
Range: **0** to **9999**
Default Value: **0**

Displays and sets the alarm reset delay time in seconds. The reset time is common for both alarm high and low setpoint values. With the alarm condition is removed the alarm relay will stay in its alarm condition for the time selected as the reset time. If the input moves back into alarm condition during this period the timer will reset and the full time delay will be restored. The reset time is selectable over **0** to **9999** seconds. To set a reset time value go to the ***R_xr_t*** function and use the **▲** or **▼** push buttons to set the value required then press **■** to accept this value.

Example: If ***R₁r_t*** is set to **10** seconds then the resetting of alarm relay 1 will be delayed by 10 seconds.

5.8 Alarm relay normally open/closed

Display: ***R_xn.o*** or ***R_xn.c***
Range: ***R_xn.o*** or ***R_xn.c***
Default Value: ***R_xn.o***

Displays and sets the setpoint alarm relay *x* action to normally open (de-energised) or normally closed (energised), when no alarm condition is present. Since the relay will always open when power is removed a normally closed alarm is often used to provide a power failure alarm indication. To set the alarm relay for normally open or closed go to the ***R_xn.o*** or ***R_xn.c*** function and use the **▲** or **▼** push buttons to set the required operation then press **■** to accept this selection. **Example:** If set to ***R₁n.o*** alarm relay 1 will be open circuit when the display is outside alarm condition and will be closed (short circuit across terminals) when the display is in alarm condition.

5.9 Alarm relay setpoint or trailing operation

Display: ***R_xSP*** or ***R_xt_i*** etc.
Range: ***R_xSP*** or ***R_xt_i*** etc.
Default Value: ***R_xSP***

Relay operation independent setpoint or trailing setpoint, this function only be seen where more than one relay is fitted. Each alarm relay, except relay 1, may be programmed to operate with an independent setpoint value or may be linked to operate at a fixed difference to another relay setpoint, known as trailing operation. The operation is as follows:

Alarm 1 (***R₁***) is always independent. Alarm 2 (***R₂***) may be independent or may be linked to Alarm 1. Alarm 3 (***R₃***) may be independent or may be linked to Alarm 1 or Alarm 2. Alarm 4 (***R₄***) may be independent or may be linked to Alarm 1, Alarm 2 or Alarm 3. The operation of each alarm is selectable by selecting, for example, (Alarm 4) ***R₄SP*** = Alarm 4 normal setpoint or ***R₄t₁*** = Alarm 4 trailing Alarm 1 or ***R₄t₂*** = Alarm 4 trailing Alarm 2 or ***R₄t₃*** = Alarm 4 trailing Alarm 3. For trailing set points the setpoint value is entered as the difference from the setpoint being trailed. If the trailing setpoint is to operate ahead of the prime setpoint then the value is entered as a positive number and if operating behind the prime setpoint then the value is entered as a negative number.

Example: With Alarm 2 set to trail alarm 1, if **R1H** is set to **1000** and **R2H** is set to **50** then Alarm 1 will activate at **1000** and alarm 2 will activate at **1050** (i.e. 1000 + 50). If Alarm 2 had been set at **-50** then alarm 2 would activate at **950** (i.e. 1000 - 50).

5.10 Display brightness

Display: **br9t**
Range: **1** to **15**
Default Value: **15**

Displays and sets the digital display brightness. The display brightness is selectable from **1** to **15**, where **1** = lowest intensity and **15** = highest intensity. This function is useful for improving the display readability in dark areas or to reduce the power consumption of the instrument. See also the **dull** function. To set brightness level go to the **br9t** function and use the **▲** or **▼** push buttons to set the value required then press **F** to accept this value.

5.11 Display remote brightness switching

Display: **dull**
Range: **0** to **15**
Default Value: **1**

Displays and sets the level for remote input brightness switching, see **FINP** function. When a remote input is set to **dull** the remote input can be used to switch between the display brightness level set by the **br9t** function 5.10 and the display brightness set by the **dull** function. The display dull level is selectable from **0** to **15**, where **0** = lowest intensity and **15** = highest intensity. This function is useful in reducing glare when the display needs to be viewed in both light and dark ambient light levels. To set dull level go to the **dull** function and use the **▲** or **▼** push buttons to set the value required then press **F** to accept this value.

Example: With **dull** set to **4** and **br9t** set to **15** and the **FINP** function set to **dull** the display brightness will change from the **15** level to **4** when a switch connected to the remote input terminals is activated.

5.12 Bargraph low value

Display: **bar_**
Range: Any display value
Default Value: **0**

Seen only in bargraph display instruments. Displays and sets the bar graph low value i.e. the value on the 7 segment display at which the bargraph will start to rise. This may be independently set anywhere within the display range of the instrument. Note: The **bar_** and **bar^** settings are referenced from the 7 segment display readings, not the bargraph scale values. The bargraph scale may be scaled differently to the 7 segment display. For example the bargraph scale may be indicating percentage fill of a tank whilst the 7 segment display is indicating actual process units. To set bargraph low level go to the **bar_** function and use the **▲** or **▼** push buttons to set the value required then press **F** to accept this value.

5.13 Bargraph high value

Display: **bAr[~]**
Range: Any display value
Default Value: **1000**

Seen only in bargraph display instruments. Displays and sets the bar graph high value i.e. the value on the 7 segment display at which the bargraph will reach its maximum indication (e.g. all LEDs illuminated). May be independently set anywhere within the display range of the instrument. To set bargraph high level go to the **bAr[~]** function and use the **▲** or **▼** push buttons to set the value required then press **F** to accept this value.

5.14 Bargraph type for instruments with bargraph display

Display: **bAr TYPE**
Range: **bAr**, **S.dot**, **d.dot**, **C.bAr** or **r.dot**
Default Value: **bAr**

Bar graph display operation mode - seen only in vertical or circular bargraph display instruments. Allows selection of bargraph operation mode. Choices available are:

- **bAr** - conventional solid bargraph display i.e. all LEDs illuminated when at full scale. When scaling the display use the **bAr₋** and **bAr[~]** functions e.g. **bAr₋ = 0** and **bAr[~] = 100** will give a bargraph with no segments lit at a 7 segment display reading of **0** and all segments lit with a 7 segment display reading of **100**.
- **S.dot** - single dot display. A single segment will be lit to indicate the input readings position on the scale. When scaling the display use the **bAr₋** and **bAr[~]** functions e.g. **bAr₋ = 0** and **bAr[~] = 100** will give a bargraph with the bottom segment lit at a 7 segment display reading of **0** and the top segment lit with a 7 segment display reading of **100**. Note: this could also be set up as a centre zero single dot display by entering a negative value and positive value. e.g. **bAr₋ = -100**, **bAr[~] = 100**.
- **d.dot** - double dot display. Two segments will be lit to indicate the input reading position on the scale. The reading should be taken from the middle of the two segments. When scaling the display use the **bAr₋** and **bAr[~]** functions e.g. **bAr₋ = 0** and **bAr[~] = 100** will give a bargraph with the bottom two segments lit at a 7 segment display reading of **0** and the top two segments lit with a 7 segment display reading of **100**. Note: this could also be set up as a centre zero double dot display by entering a negative value and positive value. e.g. **bAr₋ = -100**, **bAr[~] = 100**.
- **C.bAr** - centre bar display. The display will be a solid bargraph but will have its zero point in the middle of the display. If the seven segment display value is positive the bargraph will rise. If the seven segment display value is negative then the bargraph will fall. When scaling the display use the **bAr₋** and **bAr[~]** functions e.g. **bAr₋ = 0** and **bAr[~] = 100** will give a bargraph with all the bottom half segments lit at a 7 segment display reading of **-100** and all the top segments lit with a 7 segment display reading of **100**.
- **r.dot** - modulus or wrap around single dot bargraph. This mode of operation allows the bargraph to wrap around the limits set by the **bAr₋** and **bAr[~]** functions by dividing the 7 segment display by the modulus (the modulus is the difference between 0 and **bAr[~]**) and displaying the remainder. For example if **bAr₋** is set to **0** and **bAr[~]** is set to

10 then in other bargraph modes when the 7 segment display reads a value such as **25** the bargraph would be stuck at the high limit of its travel since it cannot go beyond **10**. In **r.dot** mode the display will wrap around at **10** then continue up the bar again and will be at the midpoint of the bargraph when the 7 segment display shows **25** (as it would for a 7 segment display of **15**, **35**, etc.). In this example for a 7 segment display of **25** the value of 25 is divided by the modulus value of 10 in this example and the remainder displayed i.e. 10 goes into 25 twice with the remainder of 5 and so a bargraph position of 5 is displayed. This mode will operate on both vertical and circular bargraph type displays.

5.15 Digital output option mode

Display: **d90P**
 Range: **bcd**, **b.SCL**, **b, n** or **b, n2**
 Default Value: **b, n2**

Seen only with the 16 bit digital output option. Refer to the separate “PM4 Panel Meter Optional Output Addendum” booklet supplied when this option is fitted. Selections available are: **b, n2** (signed binary) i.e. -32767 to 32767, **b, n** (unsigned binary) i.e. 0 to 65535, **b.SCL** (scaled binary, see **d, 9-** and **d, 9-** below), **bcd** (binary coded decimal) i.e. up to four BCD numbers. .

5.16 Digital output option polarity

Display: **d9.OP**
 Range: **Al 0** or **AH,**
 Default Value: **Al 0**

Seen only with the 16 bit digital output option. Refer to the separate “PM4 Panel Meter Optional Output Addendum” booklet supplied when this option is fitted. Selections available are: **Al 0** (active low i.e. logic 1 = 0V output, logic 0 = +V output) or **AH,** (active high i.e. logic 1 = +V output, logic 0 = 0V output).

5.17 Digital output option BCD start position

Display: **bcd Start**
 Range: **0**, **1** or **2**
 Default Value: **0**

Seen only with the 16 bit digital output option. Refer to the separate “PM4 Panel Meter Optional Output Addendum” booklet supplied when this option is fitted. This function affects BCD mode only and determines the number of digits to skip when outputting from the display. As the output is 16 bit it can output up to 4 BCD numbers. Select from **0** to number of display digits minus 4. e.g. for a 6 digit display you may select **0** to **2**, if **2** is selected then the four left most digits will be output, if set to **0** then the four right most digits will be output.

5.18 Digital output option low value

Display: **d, 9-**
Range: Any display value
Default Value: **0**

Seen only with the 16 bit digital output option. Refer to the separate “PM4 Panel Meter Optional Output Addendum” booklet supplied when this option is fitted. Accepts any valid display value. Determines the low scaling point for the **b.5CL** mode and has no effect on other modes. See example which follows in 5.19.

5.19 Digital output option high value

Display: **d, 9^**
Range: Any display value
Default Value: **1000**

Seen only with the 16 bit digital output option. Refer to the separate “PM4 Panel Meter Optional Output Addendum” booklet supplied when this option is fitted. Determines the high scaling point for the **b.5CL** mode and has no effect on other modes.

Example: If **d, 9-** is set to **0** and **d, 9^** is set to **65535** ($2^{16} - 1$) then the retransmission will not be scaled i.e. a display of **2** will cause a retransmission of 2. If **d, 9^** is now changed to **32767** ($2^{15} - 1$) then a display of **2** will cause a retransmission of 4 (note: rounding may occur on retransmission).

5.20 Analog output option low value

Display: **fEE-**
Range: Any display value
Default Value: **0**

Seen only when analog retransmission option fitted. Refer to the separate “PM4 Panel Meter Optional Output Addendum” booklet supplied when this option is fitted for wiring details and link settings. Displays and sets the analog retransmission (4–20mA, 0–1V or 0–10V, link selectable) output low value (4mA or 0V) in displayed engineering units. To set the analog output low value go to the **fEE-** function and use the **▲** or **▼** push buttons to set the required value then press **F** to accept this selection.

Example: If it is required to retransmit 4mA when the display indicates **0** then select **0** in this function using the **▲** or **▼** button.

5.21 Analog output option high value

Display: **fEE^**
Range: Any display value
Default Value: **1000**

Seen only when analog retransmission option fitted. Refer to the separate “PM4 Panel Meter

Optional Output Addendum” booklet supplied when this option is fitted for wiring details and link settings. Displays and sets the analog retransmission (4–20mA, 0–1V or 0–10V, link selectable) output high display value (20mA, 1V or 10V) in displayed engineering units. To set the analog output high value go to the **FEE-** function and use the **▲** or **▼** push buttons to set the required value then press **F** to accept this selection.

Example: If it is required to retransmit 20mA when the display indicates **50** then select **50** in this function using the **▲** or **▼** button.

5.22 Second analog output option low value

Display: **FEE- CH2**
Range: Any display value
Default Value: **0**

See **FEE-** function 5.20 for description of operation.

5.23 Second analog output option high value

Display: **FEE+ CH2**
Range: Any display value
Default Value: **1000**

See **FEE+** function 5.21 for description of operation.

5.24 Display rounding

Display: **drnd**
Range: **1** to **5000**
Default Value: **1**

Displays and sets the display rounding value for the rate/frequency display only. This value may be set to 1 - 5000 displayed units. Display rounding is useful for reducing the instrument resolution without loss of accuracy in applications where it is undesirable to display to a fine tolerance. To set the display rounding value go to the **drnd** function and use the **▲** or **▼** push buttons to set the required value then press **F** to accept this selection.

Example:

If set to **10** the rate/frequency display values will change in multiples of 10 only i.e. display moves from **10** to **20** to **30** etc.

5.25 Decimal point

Display: **dCPE**
Range: **0, 0.1** etc.
Default Value: **0**

Displays and sets the decimal point. By pressing the **▲** or **▼** pushbutton at the **dCPE** function

the decimal point position may be set. The display will indicate as follows: **0** (no decimal point), **0.1** (1 decimal place), **0.02** (2 decimal places), **0.003** (3 decimal places) and **0.0004** for display with more than 4 digits. Note if the decimal point is altered the display will need to be recalibrated and alarm etc. settings checked.

5.26 Digital filter

Display: **FLtr**
Range: **0** to **8**
Default Value: **2**

Displays and sets the digital filter value. Digital filtering uses a weighted average method of determining the display value and is used for reducing display value variation due to short term interference. The digital filter range is selectable from **0** to **8**, where **0** = none and **8** = most filtering. Use **▲** or **▼** at the **FLtr** function to alter the filter level if required. Note that the higher the filter setting the longer the display may take to reach its final value when the input is changed, similarly the relay operation and any output options will be slowed down when the filter setting is increased. To set the digital filter value go to the **FLtr** function and use the **▲** or **▼** push buttons to set the required value then press **F** to accept this selection.

5.27 Analog output PI control

Display: **rectrl**
Range: **on** or **OFF**
Default Value: **OFF**

Analog output mode - seen only when analog output option is fitted. This function allows selection of **on** or **OFF** for PI control analog output. If set to **OFF** the analog output operates as a retransmission output and uses the functions described in this chapter. If set to **on** the analog output operates as a PI control output.

When this function is set to **on** the following associated functions will appear: **C.SET**, **C.SPn**, **C.P9**, **C.P0**, **C.I9**, **C.I.H**, **C.I.L** and **FEC SPAC**. These functions are not detailed in this manual. Refer to the separate “PM4 Panel Meter Optional Output Addendum” booklet for description of the analog PI control functions and wiring details.

5.28 First calibration scaling point

Display: **CAL 1**
Range: Any display value
Default Value: n/a

First scaling point for 2 point calibration scaling - See “Calibration” chapter, section 6.1.

5.29 Second calibration scaling point

Display: **CAL2**
Range: Any display value
Default Value: n/a

Second scaling point for 2 point calibration scaling - See “Calibration” chapter, section 6.1.

5.30 Calibration offset

Display: **CAL OFFSE**
Range: Any display value
Default Value: n/a

Calibration offset - See section 6.2.

5.31 Zero range

Display: **ZERO RANGE**
Range: Any display value or **OFF**
Default Value: **OFF**

Zero range limit value - see section 6.3.

5.32 Zero reference point for **ZERO RANGE** operation

Display: **CAL ZERO**
Range: n/a
Default Value: n/a

Zero point calibration for **ZERO RANGE** function - see section 6.4.

5.33 4mA input scale

Display: **USER EN4**
Range: Any display value
Default Value: n/a

4mA input scale value, use only as an alternative to **CAL 1** and **CAL 2** calibration - See “Calibration” chapter, section 6.5.

5.34 20mA input scale

Display: **USEF E_n20**
Range: Any display value
Default Value: n/a

20mA input scale value, use only as an alternative to **CAL 1** and **CAL 2** calibration - See “Calibration” chapter, section 6.5.

5.35 Uncalibrate

Display: **UCAL**
Range: n/a
Default Value: n/a

Uncalibrate, resets calibration - required only when a calibration problem occurs and it is necessary to clear the calibration memory. At the **UCAL** function press the **▲** and **▼** buttons simultaneously. The message **CAL CLR** should be seen to indicate that the calibration memory has been cleared.

5.36 **P** button function

Display: **Pbut**
Range: **NONE**, **H**, **.Lo**, **H**, **Lo**, **2EFO**, **d**, **SP**, or **CLF.t**
Default Value: **NONE**

P button function - a only applicable models with front panel **P** buttons. The **P** button may be set to operate some of functions also available via the remote input, see **F.I NP** below for a description of these functions. The **P** button is located at the front of 5, 6 or 8 digit LED models and bargraph models. If both the remote input and **P** button function are operated simultaneously the **P** button will override the remote input. See the **F.I NP** function below for details of operation of the available functions. Note: To prevent accidental operation of the **P** button in the **2EFO** and **CLF.t** functions it is necessary to hold the button in for 2 seconds to perform the selected operation.

5.37 Remote input function

Display: **F.I NP**
Range: **NONE**, **P.HLd**, **d.HLd**, **H**, **.Lo**, **H**, **Lo**, **2EFO**, **SP.Ac**, **No.Ac**, **CAL.S**, **dULL**, **d**, **SP** or **CLF.t**
Default Value: **NONE**

Remote input function - When remote input terminals 7 and 8 are short circuited, via a switch, relay, keyswitch etc. the instrument will perform the selected remote input function. A message will flash (e.g. **2EFO** to indicate which function has been selected when the remote input pins are short circuited. The remote input functions are as follows:

- **NONE** - no remote function required i.e. activating the remote input has no effect.

- **P.HLd** - rate peak hold. The display will show the peak rate value (highest positive value) only whilst the remote input terminals are short circuited i.e. the display value can rise but not fall whilst the input terminals are short circuited. The message **P.HLd** will appear briefly every 8 seconds whilst the input terminals are short circuited to indicate that the peak hold function is active.
- **d.HLd** - rate display hold. The rate display value will be held whilst the remote input terminals are short circuited. The message **d.HLd** will appear briefly every 8 seconds whilst the input terminals are short circuited to indicate that the display hold function is active. The totaliser will still be active and will sample the live input rather than the held input whilst the rate is held i.e. the rate display hold does not affect the totaliser operation.
- **H_i** - rate peak memory. The rate peak value stored in memory will be displayed if the remote input terminals are short circuited, if the short circuit is momentary then the display will return to normal measurement after 20 seconds. If the short circuit is held for 2 to 3 seconds or the power is removed from the instrument then the memory will be reset.
- **L_o** - rate valley memory. The rate minimum value stored in memory will be displayed. Otherwise operates in the same manner as the **H_i** function described above.
- **H_i L_o** - rate toggle between **H_i** and **L_o** displays. This function allows the remote input to be used to toggle between rate peak and valley memory displays. The first operation of the remote input will cause the peak memory value to be displayed, the next operation will give a valley memory display. **PH_i** or **PL_o** will flash before each display to give an indication of display type.
- **ZEFO** - rate display zero. Zeroes the rate display when the remote input is shorted. The input at the time of the **ZEFO** operation will become the new zero point. The zero operation shifts the calibration in the same manner as a calibration offset operation.
- **SP.Ac** - setpoint access only. This mode blocks access to any functions except the alarm setpoint functions unless the remote input pins are short circuited or entry is made via **CAL** mode or if the **ACCS** function is set to either **EASY** or **ALL**.
- **No.Ac** - no access. This mode blocks access to all functions unless the remote input pins are short circuited or entry is made via **CAL** mode or if the **ACCS** function is set to **ALL**.
- **CAL.S** - rate calibration select. The remote input can be used to select between rate calibration scaling values. Two sets of calibration values can be entered in the instrument, one set with the remote input open circuit and another set with the remote input short circuit to ground. The remote input can then be used to switch between one set and the other. This feature can be used on all input ranges. For example: With the remote input open circuit a 4-20mA input can be scaled (using **CAL 1** and **CAL 2** or **USER En4** and **USER En20**) to read **0** to **100** over the 4-20mA range. With the remote input short circuit to ground the scaling can be repeated using figures of **0** to **500** for the 4-20mA range. The remote input can be used to switch between ranges. In this example the first scaling could represent a % figure and the second scaling could represent the actual process units (litres, kg, volts etc).
- **dULL** - display brightness control. The remote input can be used to change the display brightness. When this mode is selected the display brightness can be switched, via the remote input terminals, between the brightness level set at the **br9t** function and the brightness level set at the **dULL** function.
- **d:SP** - display switching. The remote input can be used to switch between rate and total displays when set to this mode. The display will show the message **tot1** or **rate** prior to the reading to indicate which value is to be displayed. If the remote input switch is held closed

then the **totl** or **rAtE** message will appear briefly approximately once every 8 second to reinforce that the display has been switched away from its default display setting.

- **CLF.t** - clear total. This function allows the total to be cleared (reset to zero). The message **CLrd** will appear when this function is operated.

5.38 Access mode

Display: **ACCS**
Range: **OFF.EASY.NONE** or **ALL**
Default Value: **OFF**

Access mode - the access mode function **ACCS** has four possible settings namely **OFF.EASY.NONE** and **ALL**. If set to **OFF** the mode function has no effect on alarm relay operation. If set to **EASY** the “easy alarm access” mode will be activated. Refer to “Easy alarm relay adjustment access facility” section. If set to **NONE** there will be no access to any functions via **FUNC** mode, entry via **CAL** mode must be made to gain access to alarm and calibration functions. If set to **ALL** then access to all functions, including calibration functions, can be gained via **FUNC** mode.

5.39 Setpoint access mode

Display: **SPAC**
Range: **A1.A1-2** etc.
Default Value: **A1**

Setpoint access - seen only if more than 1 relay fitted. Sets the access via **FUNC** mode and “easy alarm access” mode to the alarm relay setpoints. The following choices are available:

A1 - Allows setpoint access to alarm 1 only.

A1-2 - Allows setpoint access to alarms 1 and 2 only.

A1-3 - Allows setpoint access to alarms 1, 2 and 3 etc. up to the maximum number of relays fitted.

The remote input function (**FINP**) must be set to **SPAC** for this function to operate. Note: Only the setpoints which have been given a value will be accessible e.g. if **A1H** is set to **OFF** then there will be no access to the **A1H** function when **SPAC** is used.

5.40 Square root mode

Display: **Sqrt**
Range: **on** or **OFF**
Default Value: **OFF**

Square root - selects the square root scaling to **on** or **OFF**. When set to **on** a square root function is applied to the input. When set to **OFF** the calibration is a linear function. When the square root facility is used the scaled displayed value follows the square root of the percentage of the full scale input value. The upper and lower input limits are set as normal as are the values to be displayed at these limits.

Note: It is essential that the display is rescaled, using **CAL1** and **CAL2** or **USEREN4** and **USEREN20**, whenever the square root function is turned on or off. The **CALDFSt** function cannot be used when the **Sqrt** function is set to **on**. **Example:**

For a 4–20mA input if you wish to display 0 at 4mA and 1000 at 20mA the square root function will calculate as follows:

At 20mA (100%) the display will be **1000** i.e. $\sqrt{1} \times 1000$.

At 16mA (75%) the display will be **866** i.e. $\sqrt{0.75} \times 1000$.

At 12mA (50%) the display will be **707** i.e. $\sqrt{0.5} \times 1000$ and so on.

5.41 Total display decimal point selection

Display: **↳0↳: √CLP↳**

Range: **0** to number of display digits minus 1

Default Value: **0**

Total decimal point selection - Displays and sets the decimal point position for the total display. For example selecting **0** will mean no decimal points (e.g. a display such as **25**), **0.1** means 1 decimal point place (e.g. **2.4**), **0.02** gives 2 decimal point places (e.g. **2.35**) etc. The maximum number of decimal point places is one less than the number of digits on the display e.g. a 4 digit display can have 3 decimal points, a 6 digit display can have 5 decimal points etc. Note: If the number of decimal points is altered then the calculated total display be affected. Always check the scaling values following a decimal point change and alter as required.

See function **E.SCL** section 5.44 for examples of adjustments required when rate and total decimal points are not the same.

5.42 Total display scaling factor

Display: **∫: SP SCL E**

Range: Any display value

Default Value: **1**

Displays and sets the display scaling factor. The scaling factor can be set anywhere in the range from 0 to the maximum display value. This factor is used in the formula to calculate the total display (see **E.SCL**). See below for examples.

5.43 Totaliser scaling factor

Display: **↳0↳: SECS**

Range: Any display value

Default Value: **50**

Displays and sets the totaliser scaling factor. The scaling factor can be set anywhere in the range from **0** to the maximum display value. This factor is used in the formula to calculate the total display (see **E.SCL**). See below for examples.

5.44 Total exponent scaling factor

Display: **E.SCL**
 Range: **0** to **9**
 Default Value: **0**

Displays and sets the exponent factor for the display. The scaling factor can be set anywhere in the range from 0 to 9. This factor allows a larger accumulated total by dividing the rate display value down to a smaller number. For example a rate display in grams can be converted to kilograms by setting **E.SCL** to **3**. The formula used to calculate the accumulated total display from the rate display is as follows:

$$Total = Previous\ total + \frac{Rate\ display \times dISP\ SCLE}{tOtL\ SECS \times 10^{ESCL}} \times Ts$$

Where: *Ts* is the time since the last sample in seconds.

Examples:

Example 1 - The instrument is connected to a flow meter and the rate is scaled to show litres per minute (L/m). The total display is required in mega litres (ML). For a flow indication of 500 L/m the total should increase by 500 litres or 0.0005ML in 1 minute. In the formula the rate display will be 500, there is no display scaling factor (**dISP SCLE**) so enter this as **1**, the totaliser scaling factor (**tOtL SECS**) will be 60 (seconds) since we are measuring in litres per minute and *Ts* will be 60 (seconds) if we wish to see the total after 1 minute. Since we are measuring in mega litres (Litres x 10⁶), the **E.SCL** value will be **6**.

$$Total = Previous\ total + \frac{500 \times 1}{60 \times 10^6} \times 60$$

$$Total = Previous\ total + 0.0005(ML)$$

Example 2 - Rate of fill measured is to be in m³/hr (cubic metres per hour) with 2 decimal points displayed. It is found that the total fill in one hour equals 4 times the rate indication, this will be the **dISP SCLE** factor. **tOtL SECS** will be 3600 (seconds i.e. 1 hour in seconds), **E.SCL** will be 0 since both rate and total are in cubic metres. For this example we will examine the increase in total after 2 hours (7200 seconds). A rate of 35.8 m³/hr we would expect an increase in the total of 286.4 m³ in 2 hours (35.8 x 4 x 2).

$$Total = Previous\ total + \frac{35.80 \times 4}{3600 \times 10^0} \times 7200$$

If **tOtL dCPE** is set to **0.02** then:

$$Total = Previous\ total + 286.40(m^3)$$

Adjustments required when different decimal points are used

If the rate decimal point setting **dCPE** and total decimal point **tOtL dCPE** settings are not the same then adjustment will have to be made in the totaliser formula to compensate. The calculation ignores the decimal points for the rate and total display so a value of 1.23 for example will be taken as being 123 for calculation purposes. If the rate and total decimal point settings are identical then this effect is canceled out. As an example if the rate display has 2 decimal points and the total display has none then the formula must be adjusted to divide the result by 100 (e.g. 123/100 gets the figure back to 1.23). For Example 2 above the result of the formula would be correctly displayed as 286.40 (assuming a previous total of 0) if the total display had two decimal points

or would incorrectly be displayed as 28640 if the totaliser had no decimal points. This could be adjusted by changing the **ESCL** value to 2 i.e.

$$Total = Previous\ total + \frac{3580 \times 4}{3600 \times 10^2} \times 7200$$

$$Total = Previous\ total + 286(m^3)$$

If the total has more decimal point places than the rate then the adjustment would have to be the other way i.e. multiplication by 10 or 100 etc. to adjust the result.

5.45 Negative total select

Display: **totl NEG**

Range: **OFF** or **on**

Default Value: **OFF**

Displays and sets whether negative totals are allowed or not. When set to OFF negative totals are not allowed and the total will not increase when the rate input is negative. Set to on to allow negative totals.

5.46 Wrap around operation

Display: **totl RAMP**

Range: **ZERO** or **STOP**

Default Value: **ZERO**

Displays and sets the totaliser wrap around operation for displays at full scale. If **STOP** is selected the display will halt at its maximum or minimum display value. If **ZERO** is selected then the display will wrap around to zero i.e. will reset itself and start again at zero.

5.47 Clear total

Display: **CLF totl**



Range: n/a

Default Value: n/a

Allows the totaliser value to be cleared via the setup pushbuttons located at the rear of the instrument. To clear the totaliser press **▲** and **▼** simultaneously at this function. The message **CLFd** will be seen to confirm that the totaliser memory has been cleared. Alternatively the **P** button or a remote input can be used to clear the total. If a remote switch is to be used the **FN RP** function must be set to **CLF.t**. If the **P** button is to be used to clear the total the **P.but** function must be set to **CLF.t**.

5.48 Default display

Display: **dfi t di SP**
Range: **RAE** or **totl**
Default Value: **RAE**

The default display may be set to total (**totl**) or rate (**RAE**). The instrument will automatically revert to its default display. The  or  button can be used to change from the default to the alternate display and the instrument will then return to the default display after a period of around 20 seconds.

5.49 Alarm relay operation mode

Display: **Ax.rE**, **Ax.tL** or **Ax.PS**
Range: **Ax.rE**, **Ax.tL** or **Ax.PS**
Default Value: **Ax.rE**

This function is used to set the operation mode for the selected relay (“x” being the relay number chosen e.g. **A1.rE**, **A2.rE** etc.). Select **Ax.rE** if the selected relay is to operate from the rate value or **Ax.tL** if the relay is to operate from the total value or **Ax.PA** if the relay is to operate from a pass value (see **Ax.PS** function).

5.50 Bargraph display operation mode

Display: **BAR**
Range: **rAE** or **totL**
Default Value: **rAE**

Allows the choice of rate or total to be displayed on the bargraph in bargraph model displays.

5.51 Analog output operation mode

Display: **rEE**
Range: **L, uE .totL .P.HLd .d.HLd .H, .Lo** or **di SP**
Default Value: **L, uE**

This section describes the operation modes available for the analog retransmission option. Note that for **P.HLd .d.HLd .H, .Lo** or **di SP** operation the **FINP** function must be set to the corresponding selection e.g. if **rEE** is set for **P.HLd** then the remote input must also be set to **P.HLd**. The following choices are available:

L, uE - live input mode. The retransmission will follow the rate display value.

totL - live input mode. The retransmission will follow the total display value.

P.HLd - peak hold mode. The 7 segment display and retransmission value will indicate the peak value only whilst the peak value function is operated via a contact closure on the remote input i.e. the 7 segment display and retransmission can rise but not fall whilst the remote input switch is closed.

d.HLd - display hold mode. The 7 segment display and retransmission value will be held whilst the remote input display hold switch is closed.

H - peak (max.) memory mode. With the peak remote input switch open the retransmission will indicate the peak value in memory i.e. the retransmission output can rise but not fall. The retransmission output can be reset by clearing the memory. The memory may be cleared either by closing the remote input switch for approximately 2 seconds or by removing power to the instrument.

Lo - valley (min.) memory mode. With the valley remote input switch open the retransmission will indicate the valley (min.) value in memory i.e. the retransmission output can fall but not rise. The retransmission output can be reset by clearing the memory. The memory may be cleared either by closing the remote input switch for approximately 2 seconds or by removing power to the instrument.

d: SP - display mode. The retransmission output will follow whatever value is on the 7 segment display. For example with the remote input is set to **d: SP** the retransmission will follow the rate when the display is toggled to show rate and will follow the total when the display is toggled to show total.

5.52 Digital output operation mode

Display: **d9.OP**
Range: **rAtE** or **totL**
Default Value: **rAtE**

Allows the choice of rate or total to be used for the optional digital retransmission output.

5.53 Low overrange visual warning limit value



Display: **Lo d: SP**
Range: Any display value or **OFF**
Default Value: **OFF**

Low overrange limit value - the display can be set to show an overrange message if the display value falls below the **Lo d: SP** setting. For example if **Lo d: SP** is set to **50** then once the display reading falls below **50** the message **-or-** will flash on and off or the display value will flash on and off instead of the normal display units (see **d: SP** function 5.55). This message can be used to alert operators to the presence of an input which is below the low limit. If this function is not required it should be set to **OFF** by pressing the **▲** and **▼** buttons simultaneously at this function.

5.54 High overrange visual warning limit value

Display: **Hi 9H d: SP**
Range: Any display value or **OFF**
Default Value: **OFF**

High overrange limit value - the display can be set to show an overrange message if the display value rises above the **Hi 9H d: SP** setting. For example if **Hi 9H d: SP** is set to **1000** then once

the display reading rises above **1000** the message **-or-** will flash on and off or the display value will flash on and off instead of the normal display units (see **di SP** function 5.55). This message can be used to alert operators to the presence of an input which is above the high limit. If this function is not required it should be set to **OFF** by pressing the  and  buttons simultaneously at this function.

5.55 Display visual warning flashing mode

Display: **di SP**
Range: **FLSH** or **-or-**
Default Value: **FLSH**

Display overrange warning flashing mode - this function is used in conjunction with the **Lo di SP** and **Hi 9H di SP** functions. The **di SP** function can be set to **FLSH** or **-or-**. If the display warning value set at the **Lo di SP** or **Hi 9H di SP** function is exceeded and the **di SP** function is set to **FLSH** then the display value will flash on and off every second as a visual warning. If the display warning value set at the **Lo di SP** or **Hi 9H di SP** function is exceeded and the **di SP** function is set to **-or-** then the **-or-** message will flash on and off once a second as a visual warning. The warning flashes will cease and the normal display value will be seen when the value displayed is higher than the low limit and lower than the high limit.

5.56 Baud rate for optional serial communications

Display: **BAUD RATE**
Range: **300 . 600 . 1200 . 2400 . 4800 . 9600 . 19.2** or **38.4**
Default Value: **9600**

Set baud rate - seen only with serial output option. Refer to the separate “PM4 Panel Meter Optional Output Addendum” booklet supplied when optional outputs are fitted. Select from **300 . 600 . 1200 . 2400 . 4800 . 9600 . 19.2** or **38.4** baud. The baud rate should be set to match the device being communicated with.

5.57 Parity for optional serial communications

Display: **Prty**
Range: **NONE . EVEN** or **odd**
Default Value: **NONE**

Set parity - seen only with serial output option. Refer to the separate “PM4 Panel Meter Optional Output Addendum” booklet supplied when optional outputs are fitted. Select parity check to either **NONE**, **EVEN** or **odd**. The parity should be set to match the device being communicated with.

5.58 Output mode for optional serial communications

Display: **0.Pub**
Range: **d, SP, Cont, POLL, R.buS** or **̄.buS**
Default Value: **Cont**

Set serial interface mode - seen only with serial output option. Refer to the separate “PM4 Panel Meter Optional Output Addendum” booklet supplied when optional outputs are fitted. Allows user to select the serial interface operation as follows:

d, SP - sends image data from the display without conversion to ASCII.

Cont - sends 8 bit ASCII form of display data at a rate typically 90% of the sample rate.

POLL - controlled by computer or PLC as host. Host sends command via RS232/485 and instrument responds as requested.

R.buS - is a special communications mode used with Windows compatible optional PC download software. Refer to the user manual supplied with this optional software.

̄.buS - Modbus RTU protocol.

5.59 Instrument address for optional serial communications

Display: **Addr**
Range: **0** to **31**
Default Value: **0**

Set unit address for polled (**POLL**) or **̄.buS** mode (**0** to **31**) - seen only with serial output option. Refer to the separate “PM4 Panel Meter Optional Output Addendum” booklet supplied when optional outputs are fitted. Allows several units to operate on the same RS485 interface reporting on different areas etc. if RS485 is available. The host computer or PLC may poll each unit in turn supplying the appropriate address. The unit address ranges from 0 to 31 (DEC) but is offset by 32 (DEC) to avoid clashing with ASCII special function characters (such as <STX> and <CR>). Therefore 32 (DEC) or 20 (HEX) is address 0, 42 (DEC) or 2A (HEX) is address 10. Do not use address 0 in **̄.buS** mode.

5.60 Serial mode for optional serial communications

Display: **SEFL**
Range: **L, uE, totL, P.HLd, d.HLd, H, Lo, H, Lo** or **both**
Default Value: **L, uE**

Seen only with serial output option - applies only when **0.Pub** function set to **Cont**. Allows selection of serial output retransmission mode. Select **L, uE** for rate value retransmission.

Select **totL** for total value retransmission.

Select **P.HLd** for peak hold retransmission (requires remote input to be set accordingly).

Select **d.HLd** for display hold retransmission (requires remote input to be set accordingly).

Select **H,** for peak memory retransmission (requires remote input to be set accordingly).

Select **Lo** for valley memory retransmission (requires remote input to be set accordingly).

Select **H, Lo** for peak/valley memory retransmission (requires remote input to be set accordingly).

The peak value will be transmitted followed by a space then the valley value.
Select **both** for both rate and total retransmission. The rate value will be transmitted followed by a space then the total value.

6 Calibration

The instrument can be calibrated via a two point live input calibration method using functions **CAL 1** and **CAL 2**. For 4-20mA inputs only an alternative method allows display scaling without live inputs using the **USER En4** and **USER En20** functions. An offset calibration scaling adjustment using the **CAL OFFSt** function is available which allows the scaling to be adjusted by a fixed amount over the entire scale. Each of these methods and other calibration scaling function are described in this chapter.

In order to gain access to the calibration functions you must be in **CAL** mode, refer to Chapter 5 page 18 which shows the method of entering **CAL** mode.

6.1 Live signal input calibration

CAL 1 and **CAL 2** - The functions **CAL 1** and **CAL 2** are used together to scale the instruments display, values for both **CAL 1** and **CAL 2** must be set when using this scaling method. The **CAL 1** function sets the first calibration point for live input calibration. When using this method different signals inputs must be present at the input terminals for **CAL 1** and **CAL 2**. Note: **CAL 1** and **CAL 2** can be set independently.

The procedure for entering the first scaling point **CAL 1** is as follows:

- Ensure that an input signal is present at the input terminals, this will usually be at the low end of the signal range e.g. 4mA for a 4-20mA input.
- At the **CAL 1** function press **▲** and **▼** simultaneously then release them. The display will show the live input value. Do not be concerned at this stage if the live input display value is not what is required. It is important that the live input value seen is a steady value, if not then the input needs to be investigated before proceeding with the scaling.
- Press then release the **F** button. The display will indicate **SCL 1** followed by a value. Use the **▲** or **▼** button to change this value to the required display value at this input. e.g. if 4mA was input and the required display at 4mA was **0** then ensure **0** is entered at **SCL 1**. Press the **F** button to accept changes or the **P** button to abort the scaling. If the scaling has been accepted the **CAL End** message should be seen.

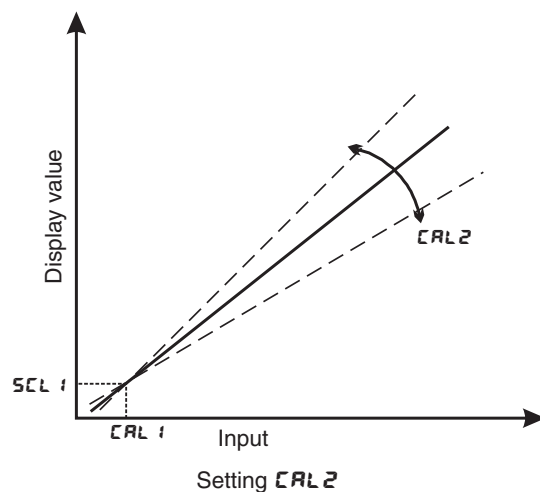
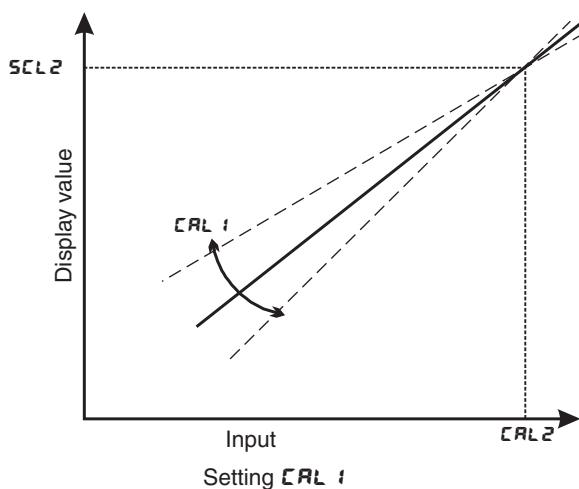

The procedure for entering the second scaling point **CAL2** is as follows:

- a. Ensure that an input signal is present at the input terminals, this will usually be at the high end of the signal range e.g. 20mA for a 4-20mA input. The change in input signal from the **CAL1** input must be at least 10% of the input range full scale.
- b. At the **CAL2** function press **▲** and **▼** simultaneously then release them. The display will show the live input value. Do not be concerned at this stage if the live input display value is not what is required. It is important that the live input value seen is a steady value, if not then the input needs to be investigated before proceeding with the scaling.
- c. Press then release the **F** button. The display will indicate **SCL2** followed by a value. Use the **▲** or **▼** button to change this value to the required display value at this input. e.g. if 20mA was input and the required display at 20mA was **500** then ensure **500** is entered at **SCL2**. Press the **F** button to accept changes or the **P** button to abort the scaling. If the scaling has been accepted the **CAL End** message should be seen.

Example - Flow chart showing scaling using two live inputs

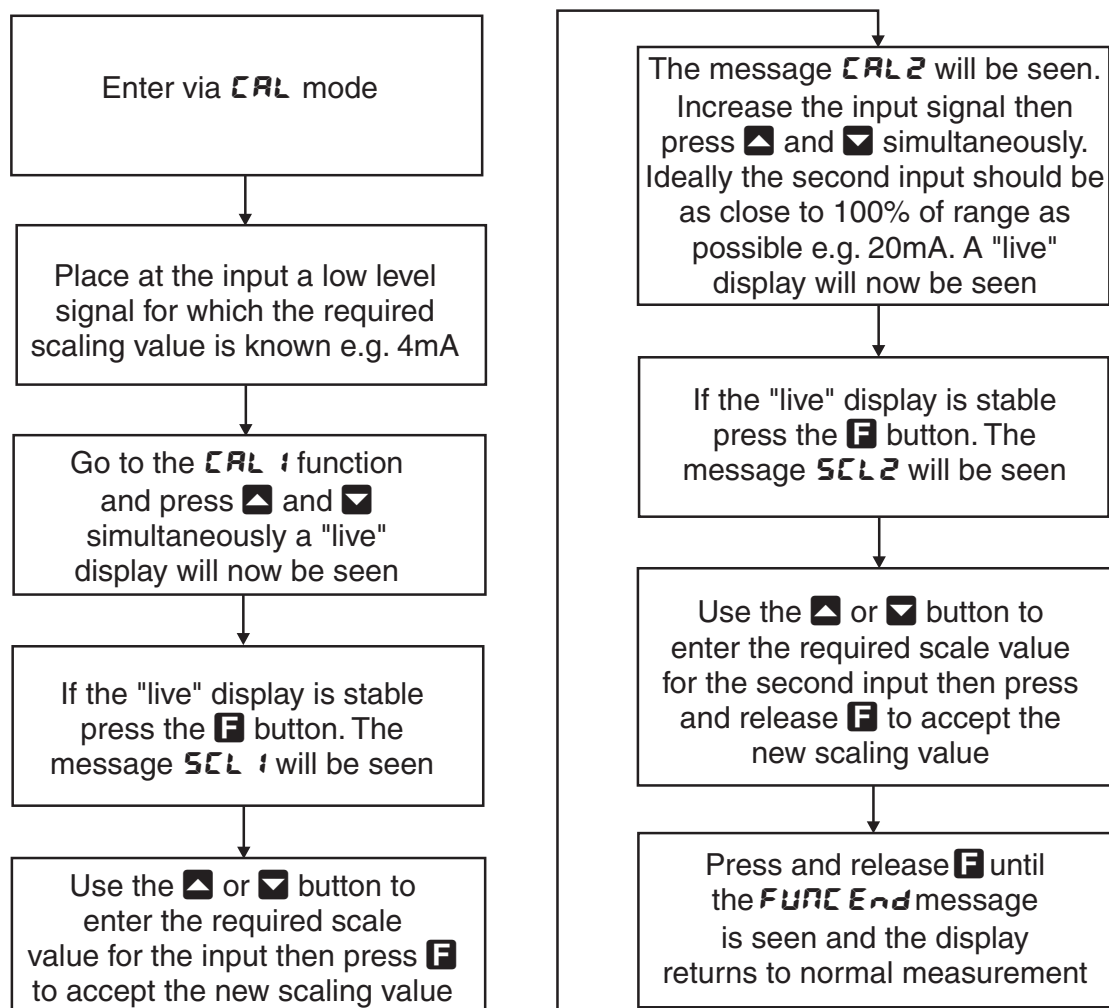

Note: If the "live" display at any scaling point is not stable then check the input signal for stability.

6.2 Offset calibration

CAL OFFSt - Calibration offset - the calibration offset is a single point adjustment which can be used to alter the calibration scaling values across the entire measuring range without affecting the calibration slope. This method can be used instead of performing a two point calibration when a constant measurement error is found to exist across the entire range. To perform a calibration offset press the **▲** and **▼** buttons simultaneously at the **CAL OFFSt** function. A “live” reading from the input will be seen, make a note of this reading. Press the **F** button, the message **SCLE** will now be seen followed by the last scale value in memory. Use the **▲** or **▼** button to adjust the scale value to the required display value for that input. For example if the “live” input reading was **50** and the required display value for this input was **70** then adjust the **SCLE** value to **70**. Press the **F** button to accept changes or the **P** button to abort the scaling. If the scaling has been accepted the message **OFFSt End** should be seen. If the **ZERO RANGE Err** message is seen refer to the **ZERO RANGE** and **CAL ZERO** functions.

6.3 Zero range

ZERO RANGE - Zero Range - the zero range function allows a limit value to be set (in engineering units) above which the display will not zero i.e. if a zero operation is attempted via the **P** button, remote input or set zero function when the display value is greater than the zero range setting the display will refuse to zero and give a **ZERO RANGE Err** message (note that the **CAL OFFSt** function is also affected by the **ZERO RANGE** setting). For example if the zero range setting is **10** the instrument will only respond to a zero operation if the display reading at the time is between **- 10** and **10**. If the zero range function is not required it can be set to **OFF** by pressing the **▲** and **▼** buttons simultaneously at this function. When switched off the instrument can be zeroed no matter what the display value. Note that the instrument keeps track of the value being zeroed at each operation, when the total amount zeroed from repeated operations becomes greater than the zero range value the instrument will reject the zero operation and a **ZERO RANGE Err** message will be seen. To allow a zero operation beyond this point either the **ZERO RANGE** function value will need to be raised or a new zero reference point introduced via the **CAL ZERO** function. If repeated zero operations are required the **ZERO RANGE** function should be set to **OFF** or alternatively the **LRGE** operation could be considered.

6.4 Zero range zero calibration

CAL ZERO - Zero range zero calibration - a **CAL ZERO** zero operation can be used to ensure that the display zero and the **ZERO RANGE** reference zero are at the same point after a calibration. After a calibration the **CAL ZERO** operation can also be used to select a zero point other than the display zero as the reference for the **ZERO RANGE** function. For example if the **CAL ZERO** operation is carried out with a display reading of **500** and a **ZERO RANGE** reading of **10** the zero range function will allow the display to zero only if the current display reading is between **490** and **510**. To perform a calibration zero press the **▲** and **▼** buttons simultaneously at the **CAL ZERO** function, a live reading will be seen, press the **F** button, the message **CAL ZERO End** should now be seen indicating that the instrument has accepted the zero point. Although the display reading will not change as a result of the calibration zero the input value on the display at the time of the operation will be the new zero reference point for the **ZERO RANGE** function.

6.5 Alternative 4-20mA scaling

USER En4 - 4mA input scaling without a live input - this calibration method can be used with 4-20mA inputs only. The instrument can be scaled for a 4-20mA input without a live input i.e. this is an alternative method to the **CAL 1** and **CAL 2** method of scaling. To perform the first point (**En4**) scaling simply press the **▲** and **▼** buttons simultaneously when the **USER En4** function is displayed. The display will now indicate a value. Use the **▲** or **▼** button to change this value to the display value required for a 4mA input. Press the **F** button to accept changes or the **P** button to abort the scaling. If the scaling has been accepted the **CAL End** message should be seen.

USER En20 - 20mA input scaling without a live input - this calibration method can be used with 4-20mA inputs only. To perform the second point (**En20**) scaling simply press the **▲** and **▼** buttons simultaneously when the **USER En20** function has been reached. The display will now indicate a value. Use the **▲** or **▼** button to change this value to the display value required for a 20mA input. Press the **F** button to accept changes or the **P** button to abort the scaling. If the scaling has been accepted the **CAL End** message should be seen.

Note: the **USER En4** and **USER En20** method relies on the accuracy of the signal input. If the sensor output is found to have an offset use the **CAL OFSt** function to correct for the offset. If the slope of the sensor output is not correct then **CAL 1** and **CAL 2** methods will have to be used.

6.6 Uncalibration

UCAL - Uncalibrate - used to set the instrument back to the factory calibration values. This function should only be used when calibration problems exist and it is necessary to clear the calibration memory. To clear the calibration memory press the **▲** and **▼** buttons simultaneously at the **UCAL** function. The message **CAL CLR** will be seen to indicate that the memory has cleared.

7 Specifications

7.1 Technical specifications

Input type:	Link selectable $\pm 2\text{mA}$, $\pm 20\text{mA}$, 4 to 20mA or DC Volts $\pm 100\text{mV}$, $\pm 1\text{V}$, $\pm 10\text{V}$, $\pm 100\text{V}$ or Slidewire, 3 wire 0-1k Ω to 0-1M Ω value slidewires
Impedance:	Typically 150 Ω for mA input (82 Ω plus polyfuse resistance) 1M Ω on DC voltage input
ADC Resolution:	1 in 20,000
Accuracy:	0.1% of input range selected when calibrated (0.3% on $\pm 100\text{mV}$ and $\pm 2\text{mA}$ ranges)
Memory retention:	Total retained for at least 1 week with power removed
Sample Rate:	4 samples per second
Display update:	4 times per second
Conversion Method:	Dual Slope ADC
Microprocessor:	HC68HC11F CMOS
Ambient temperature:	LED -10 to 60° C, LCD -10 to 50° C
Humidity:	5 to 95% non condensing
Display:	LED Models: 4 digit 20mm, 5 digit 14.2mm + status LEDs + 4 way keypad. 6 digit 14.2mm + 4 way keypad LED Bar Graph 20 segment bar + 5 digit 7.6mm + relay status LEDs LED Circular Bar Graph 16 segment + 5 digit 7.6mm + relay status LEDs LCD Models: 4 digit 12.7mm, 6 digit 12.7mm
Power Supply:	AC 240V, 110V or 24V 50/60Hz or DC isolated wide range 12 to 48V. Special supply types 32VAC, 48VAC 50/60Hz or DC isolated 50 to 110V also available. Note: supply type is factory configured.
Power Consumption:	AC supply 4 VA max, DC supply typically 160mA at 12VDC and 80mA at 24VDC for PM4 with no optional outputs, actual current drawn depends on display type and options fitted
Output (standard):	1 x relay, Form A, rated 5A resistive 18VDC (approx.) non isolated regulated transmitter supply (25mA max.)
Relay Action:	Programmable N.O. or N.C

7.2 Optional outputs

Extra Relays:	Same specs. as Relay 1 (up to 6 extra relays). Available as one, three or six extra relays.
Analog Retransmission:	12 bit isolated 4 to 20mA, 0 to 1V or 0 to 10V link selectable (single or dual analog output versions available). (4-20mA will drive into resistive loads of up to 800 Ω)
Digital Retransmission:	Isolated BCD/Binary
Serial Communications:	Isolated RS232 or RS485 (ASCII or Modbus RTU)
DC Voltage Output:	Isolated $\pm 12\text{V}(24\text{V})$ standard, $\pm 5\text{V}(10\text{V})$ link selectable (rated at 25mA).

7.3 Physical Characteristics

Bezel Size:	DIN 48mm x 96mm x 10mm
Case Size:	44mm x 91mm x 120mm behind face of panel
Panel Cut Out:	45mm x 92mm +1mm/-0mm
Connections:	Plug in screw terminals (max. 2.5mm ² wire)
Weight:	400 gms basic model, 450 gms with option card

8 Guarantee and service

The product supplied with this manual is guaranteed against faulty workmanship for a period of two years from the date of dispatch.

Our obligation assumed under this guarantee is limited to the replacement of parts which, by our examination, are proved to be defective and have not been misused, carelessly handled, defaced or damaged due to incorrect installation. This guarantee is VOID where the unit has been opened, tampered with or if repairs have been made or attempted by anyone except an authorised representative of the manufacturing company.

Products for attention under guarantee (unless otherwise agreed) must be returned to the manufacturer freight paid and, if accepted for free repair, will be returned to the customers address in Australia free of charge.

When returning the product for service or repair a full description of the fault and the mode of operation used when the product failed must be given. In any event the manufacturer has no other obligation or liability beyond replacement or repair of this product.

Modifications may be made to any existing or future models of the unit as it may deem necessary without incurring any obligation to incorporate such modifications in units previously sold or to which this guarantee may relate.

This document is the property of the instrument manufacturer and may not be reproduced in whole or part without the written consent of the manufacturer.

This product is designed and manufactured in Australia.