

PM4-AM
DC Current / DC Voltage
Auto/Manual Station
Operation and Instruction Manual
(Inputs 4-20mA, 0-1V, 0-10V & 0-100V)

AMALGAMATED INSTRUMENT CO PTY LTD

ACN: 001 589 439

Unit 5, 28 Leighton Place Hornsby
NSW 2077 AUSTRALIA

Telephone: +61 2 9476 2244
Facsimile: +61 2 9476 2902

e-mail: sales@aicpl.com.au
Internet: www.aicpl.com.au

Table of Contents

Introduction	3
Basic setup	4
Mechanical installation	5
Electrical installation	6
Selecting the input range	7
Configuring the output board	8
Connection examples	9
Input/output configuration	11
Explanation of Functions	12
Function table	26
Auto/Manual operation	28
Specifications	29
Technical Specifications	29
Output Options	29
Physical Characteristics	29
Guarantee & service	30

1 Introduction

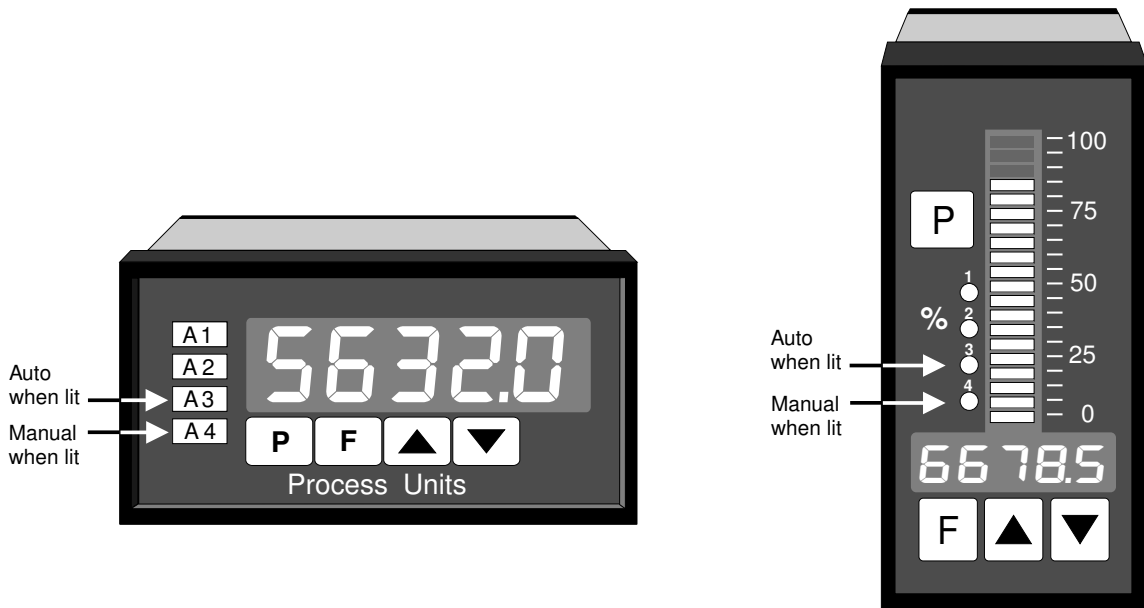

This manual contains information for the installation and operation of the PM4-AM Auto/Manual Station. The PM4-AM is a versatile instrument which may be configured to accept inputs of DC volts (0-1V or 0-10V) or 4 to 20 mA DC or 3 wire slidewire and retransmit a direct or manually controlled analog output of DC volts (0-1V or 0-10V) or 4 to 20mA. The instrument may be calibrated to display the input in engineering units. A standard inbuilt relay provides an alarm/control function, an optional second relay and excitation voltage may also be provided. Refer to Chapter 7 "Auto/Manual operation" for details of Auto/Manual switching options.

Unless otherwise specified at the time of order, your PM4 has been factory set to a standard configuration. Like all other PM4 series instruments the configuration and calibration is easily changed by the user. Initial changes may require dismantling the instrument to alter PCB links, other changes are made by push button functions.

Full electrical isolation between power supply, input voltage or current and retransmission output is provided by the PM4, thereby eliminating grounding and common voltage problems. This isolation feature makes the PM4 ideal for interfacing to computers, PLCs and other data acquisition or control devices.

The PM4 series of Panel Mount Monitors are designed for high reliability in industrial applications. The high brightness LED display provides good visibility, even in areas with high ambient light levels. The wide combination of input to output voltage and current ranges allows the PM4 to perform a signal conversion as well as Auto Manual function.

AUTOMATIC MODE

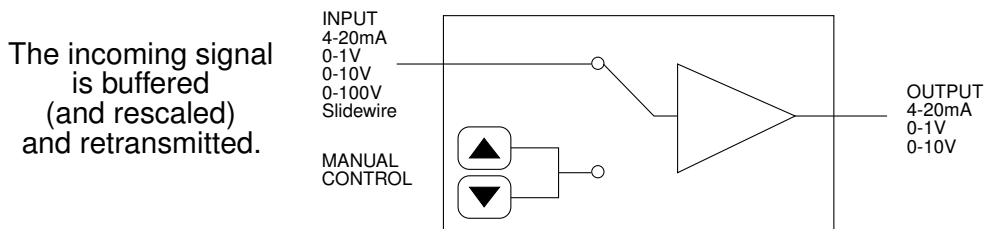

MANUAL MODE

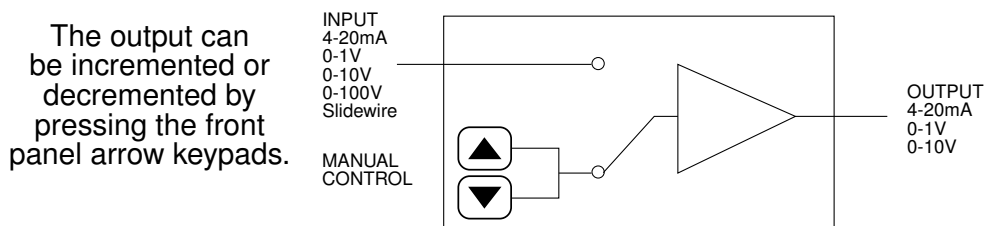

1.1 Basic setup

1. See "Mechanical Installation" and "Electrical Installation" chapters for details of panel cut out requirement, wiring and internal link setting requirements.
2. See the first page of the "Explanation of functions" chapter for details of entering **CAL** and **FUNC** modes to gain access to the instrument setup and calibration functions.
3. Calibrate the instrument if required. See **CAL 1 / CAL 2** and **USER En4 / USER En20** methods of calibration in the "Explanation of functions" chapter.
4. See the "Auto/Manual operation" chapter for details of methods of switching between Auto and Manual output.

2 Mechanical installation

If a choice of mounting sites is available then choose a site as far away as possible from sources of electrical noise such as motors, generators, fluorescent lights, high voltage cables/bus bars etc. An IP65 access cover which may be installed on the panel and surrounds is available as an option to be used when mounting the instrument in damp/dusty positions. A wall mount case is available, as an option, for situations in which panel mounting is either not available or not appropriate. An optional portable carry case is also available for panel mount instruments.

Prepare a panel cut out of 45mm x 92mm +1 mm / -0 mm (see diagram below). Insert the instrument into the cut out from the front of the panel. Then, from the rear of the instrument, fit the two mounting brackets into the recess provided (see diagram below). Whilst holding the bracket in place, tighten the securing screws being careful not to over-tighten, as this may damage the instrument.

Hint: use the elastic band provided to hold the mounting bracket in place whilst tightening securing screws.

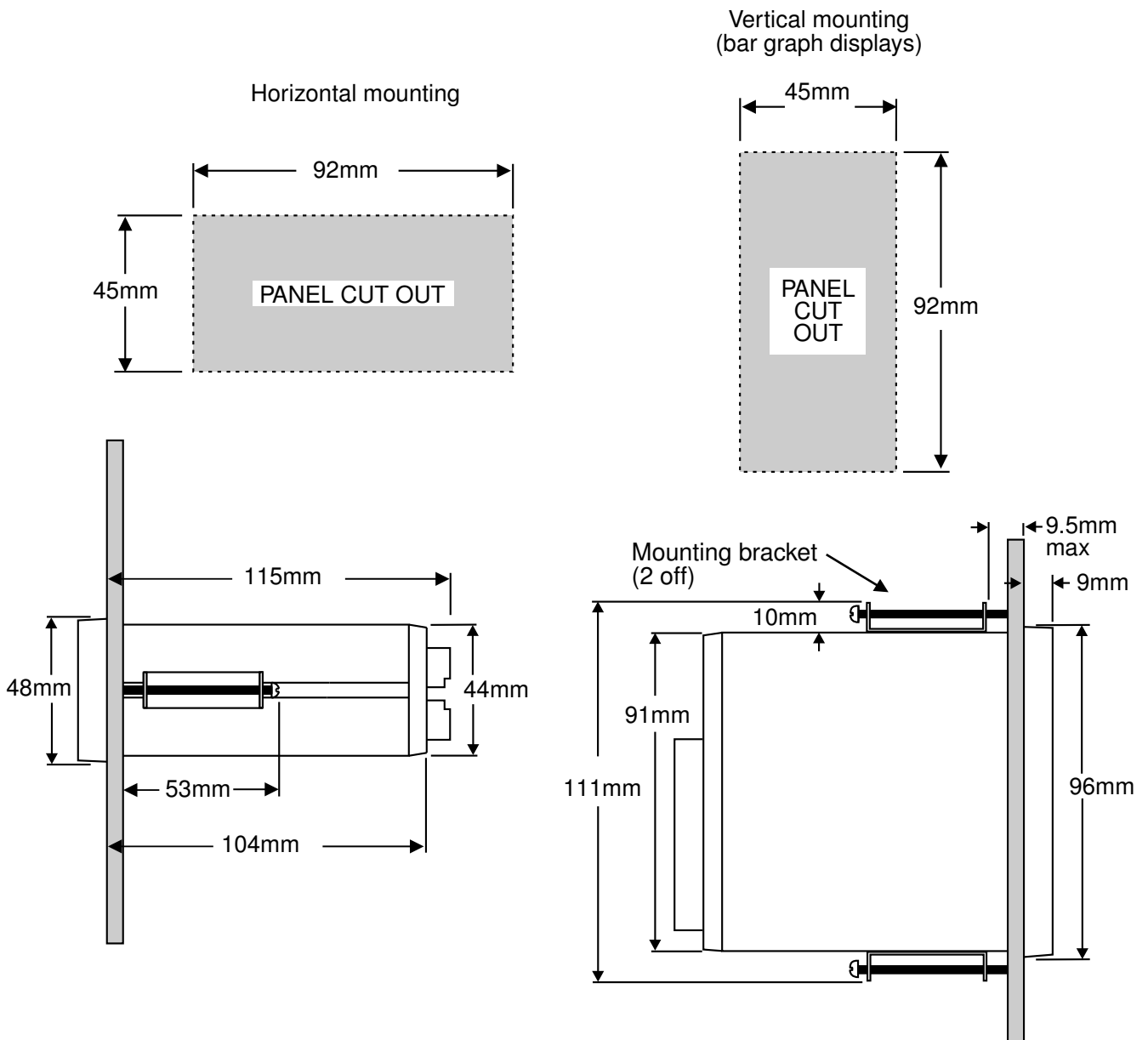

3 Electrical installation

The PM4 Panel Meter is designed for continuous operation and no power switch is fitted to the unit. It is recommended that an external switch and fuse be provided to allow the unit to be removed for servicing.

The terminal blocks allow for wires of up to 2.5mm² to be fitted. Connect the wires to the appropriate terminals as indicated below. Refer to other details provided in this manual to confirm proper selection of voltage, polarity and input type before applying power to the instrument. When power is applied the instrument will cycle through a display sequence, indicating the software version and other status information, this indicates that the instrument is functioning.

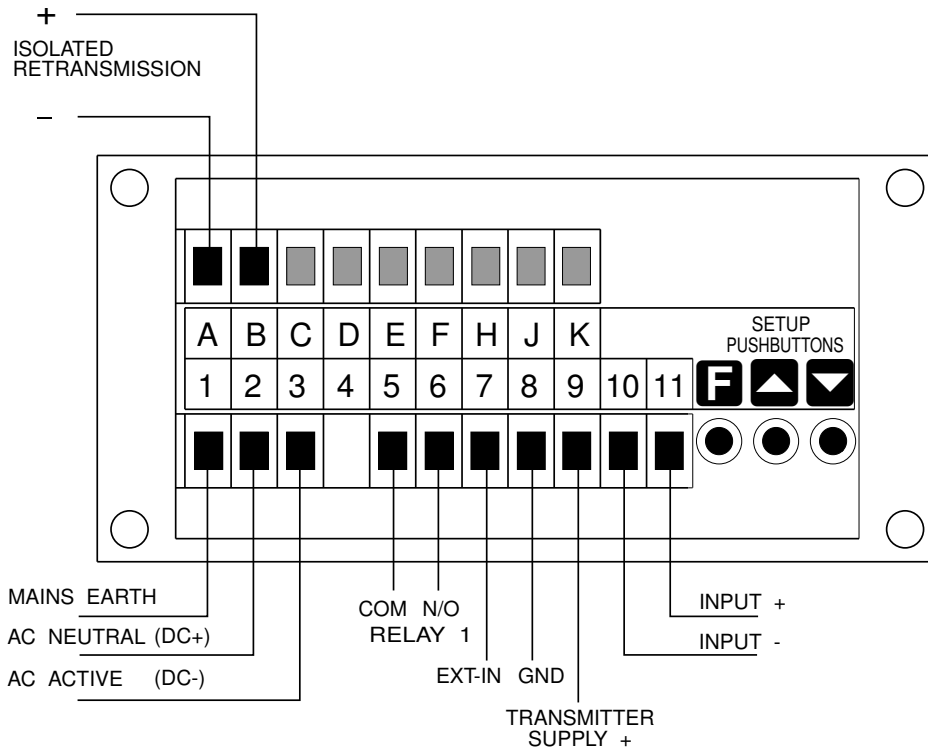

Instrument Rear Panel

1	MAINS EARTH	A	OUTPUT V/I	-
2	240VAC NEUTRAL	B	OUTPUT V/I	+
3	240VAC ACTIVE			
5	RELAY 1	COM		
6	RELAY 1	N/O		
7	EXT IN			
8	GROUND			
9	18VDC SUPPLY			
10	INPUT (GND)		-	
11	INPUT		+	
MODEL No: PM4-AM-240-5E-A			SERIAL No:	

Instrument Data Label (example)

3.1 Selecting the input range

Dismantle the instrument as described in Chapter 4, "Input/output configuration". Insert the links into the appropriate location on the pin header to suit the range required.

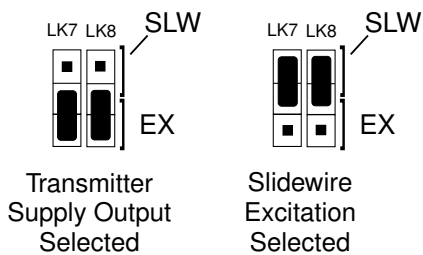

Note: All other links should be out when slidewire is selected. Slidewire excitation voltage is approx. 1.25V across terminals 9 & 10.

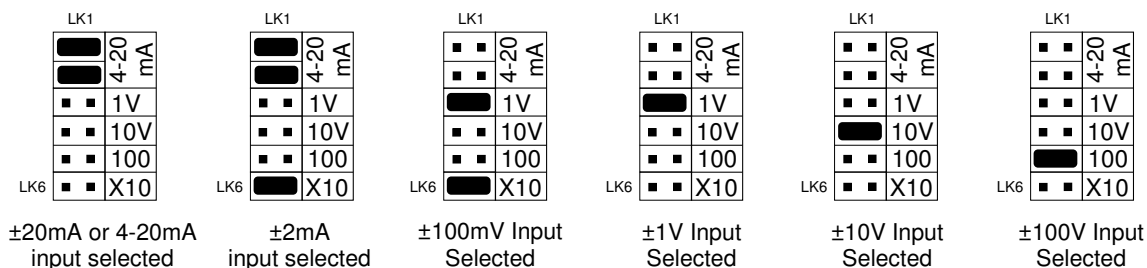
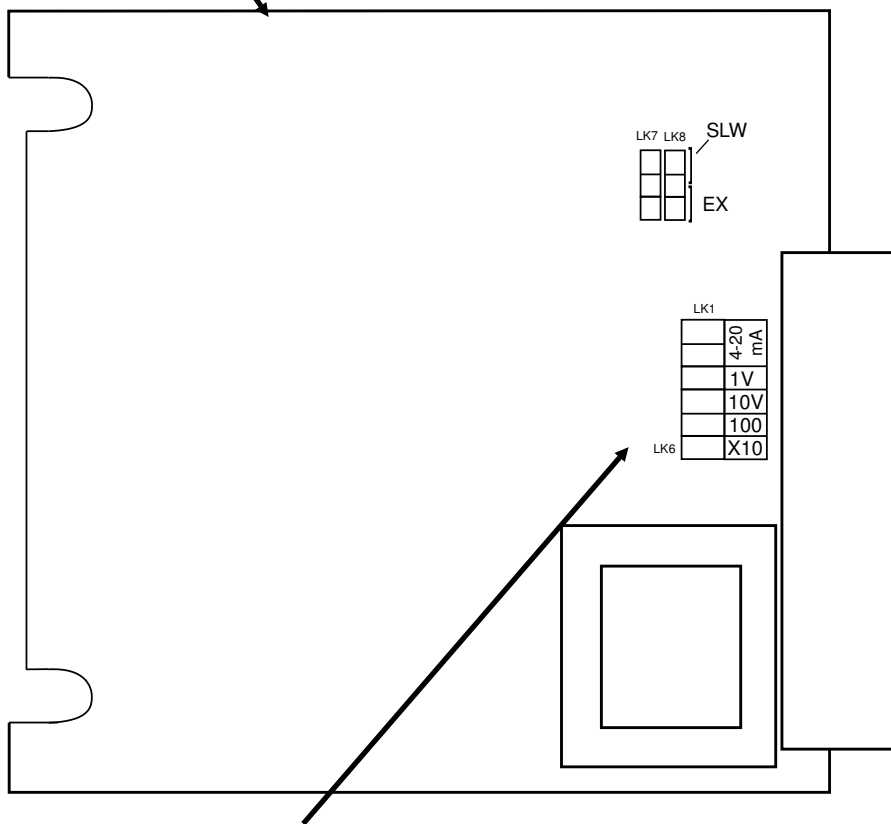

3.2 Configuring the output board

The output board has facilities for a second relay output and/or 4-20mA, 0-1V and 0-10V retransmission and/or isolated $\pm 5V$ or $\pm 12VDC$ supply depending on the options ordered.

PCB links are fitted to the circuit board to provide data to the microprocessor and to connect the electronic components for the correct output types. It may be necessary to alter the PCB links to change the analog output or DC voltage output (see link settings below). See the "Input/output configuration" section for details on dismantling the instrument.

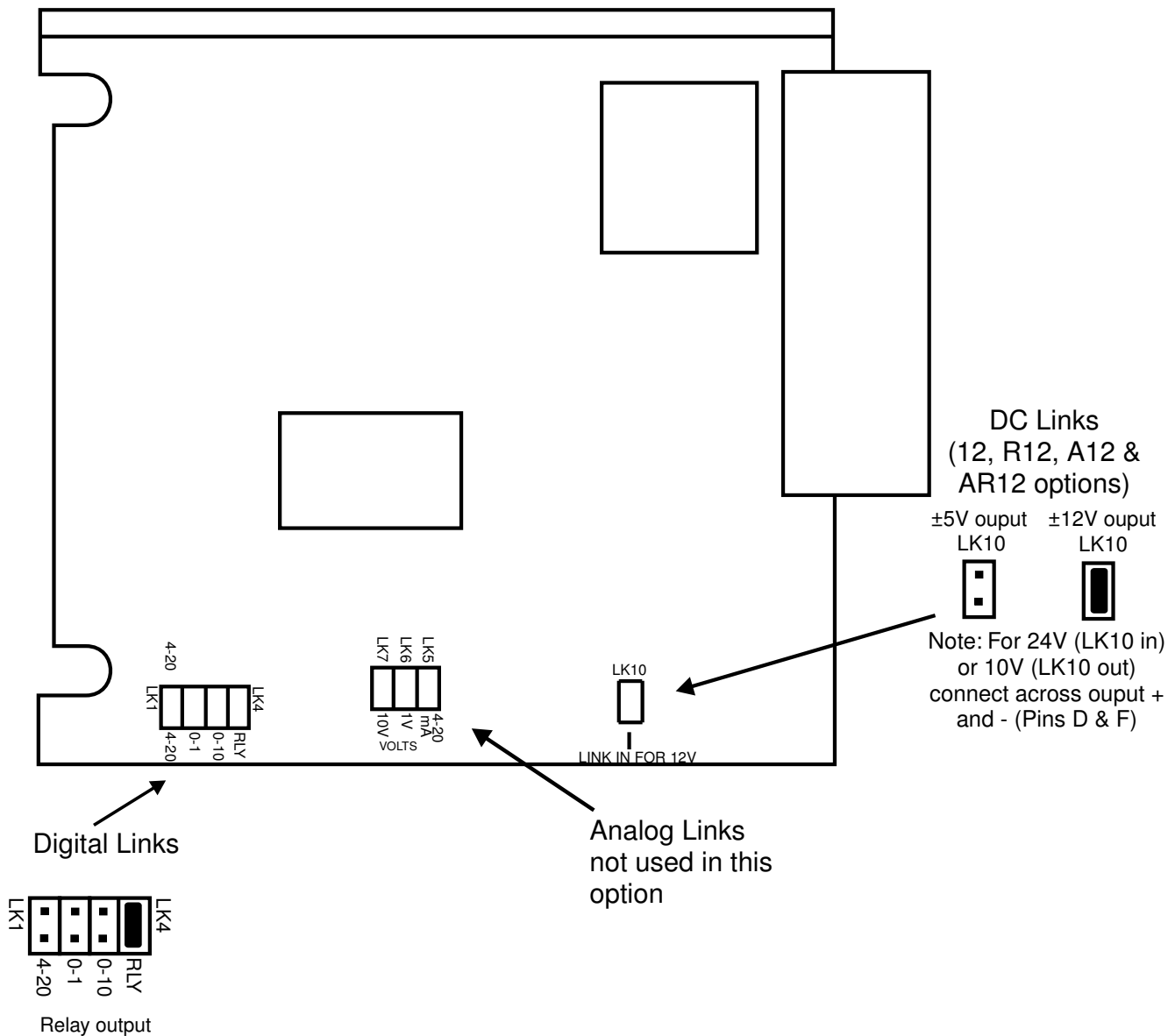

3.3 Connection examples

1. 2 wire 4-20mA - powered from PM4 standard 18V (20mA) supply - AC powered PM4 units only.

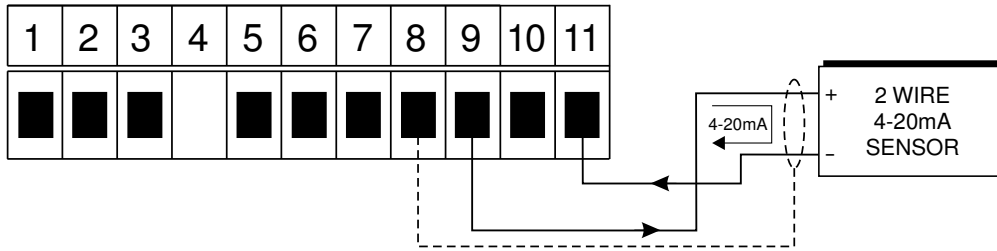

2. 2 wire 4-20mA input - externally powered sensor

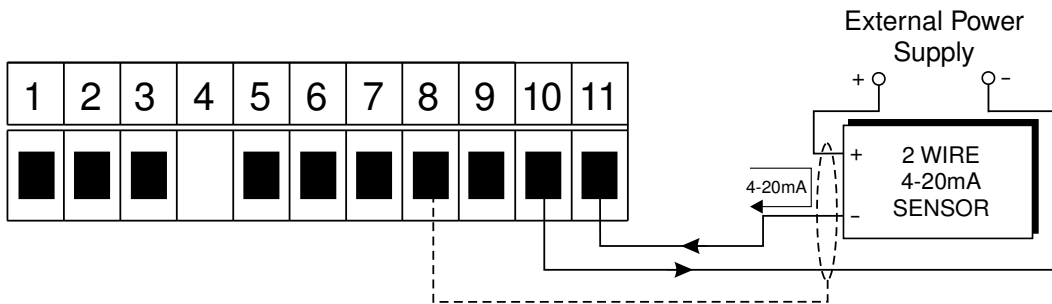

3. 3 wire 4-20mA input - externally powered sensor

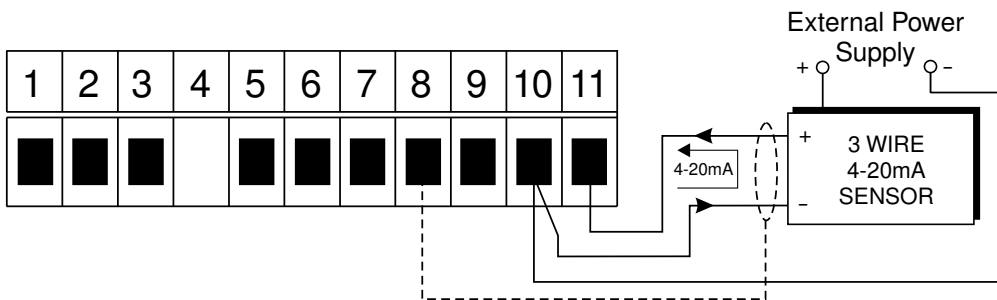

4. 4 wire 4-20mA input - externally powered sensor

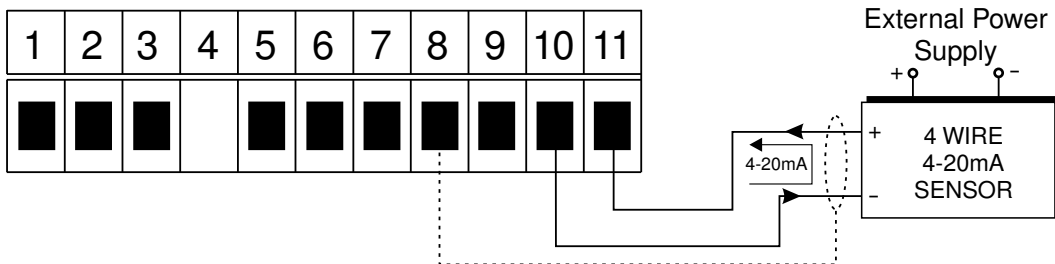

5. 3 wire 4-20mA - powered from PM4 standard 18V (20mA) supply - AC powered PM4 units only.

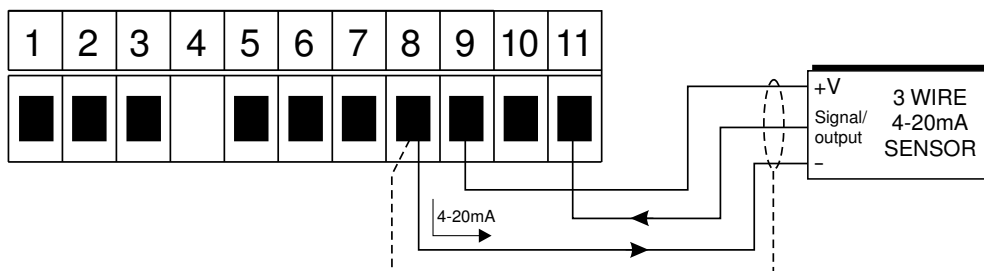

6. 4-20mA input - powered from optional ±12V (20mA) PM4 supply

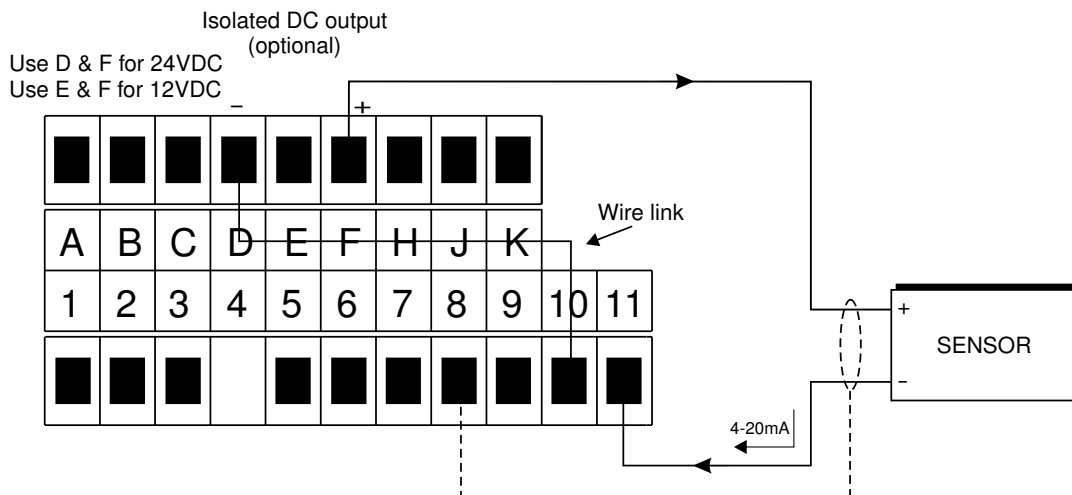

7. DC voltage input

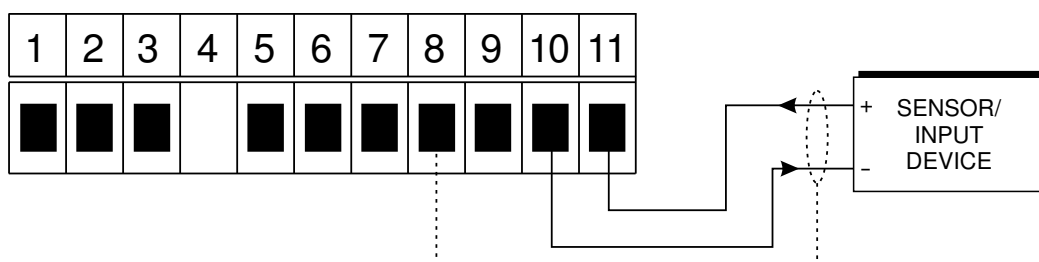

8. Slidewire input (excitation voltage 1.25VDC)

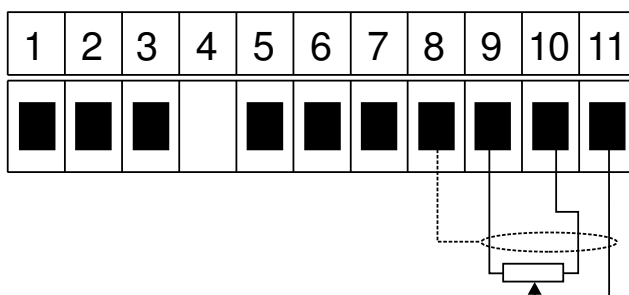

Note: Links LK7 & LK8 Must be set to SLIDE WIRE for Slide Wire input all other links should be out.

9. Remote input

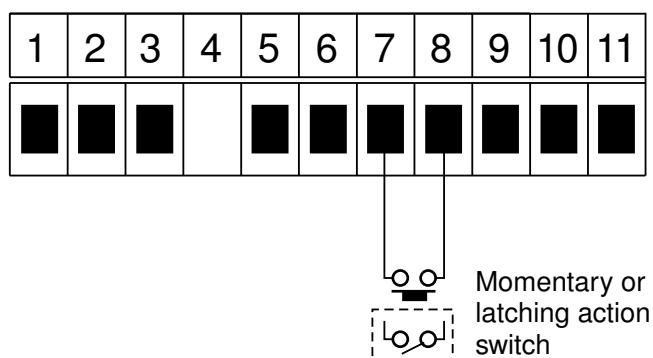

4 Input/output configuration

If you need to alter the input or output configuration proceed as follows:

1. Remove the plug in terminals from the rear of the instrument

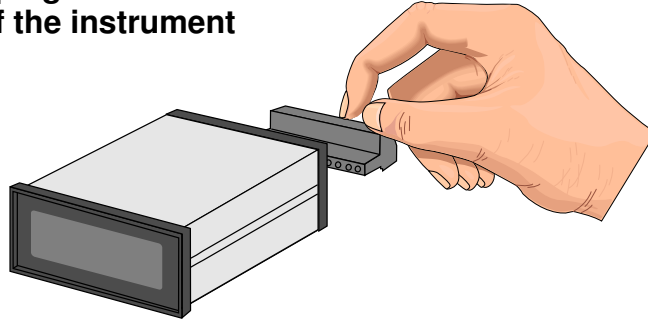

2. Remove 4 x self tapping screws from back cover, remove back cover by pulling it away from the instrument

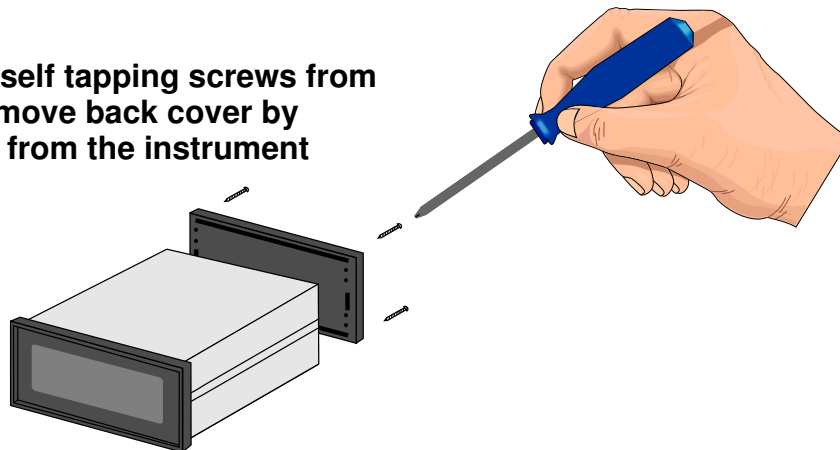

3. Using a screwdriver, remove the earth screw which passes through the case then slide out the board or boards

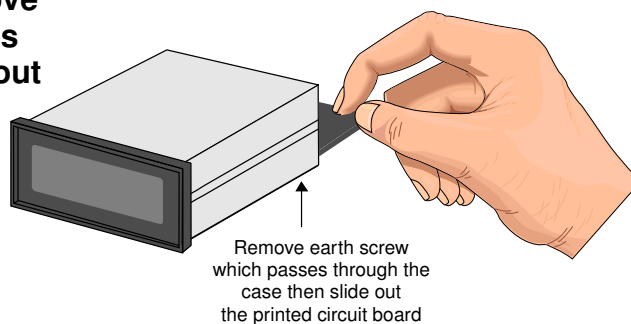

4. Configure the PCB links as required, see appropriate chapter

5. Slide PCB back into the case

6. Replace the earth screw which passes through the case

7. Refit back cover and fix with the self tapping screws

8. Plug the terminal strips back into the rear of the instrument

5 Explanation of Functions

The PM4 setup and calibration functions are configured through a push button sequence. Two levels of access are provided for setting up and calibrating:-

FUNC mode (simple push button sequence) allows access to commonly set up functions such as alarm setpoints.

CAL mode (power up sequence plus push button sequence) allows access to all functions including calibration parameters.

The front panel push buttons are used to alter settings. Once **CAL** or **FUNC** mode has been entered you can step through the functions, by pressing and releasing the **F** push button, until the required function is reached. Changes to functions are made by pressing the **▲** or **▼** push button (in some cases both simultaneously) when the required function is reached.

Entering **CAL** Mode



1. Remove power from the instrument. Hold in the **F** button and reapply power. The display will briefly indicate **CAL** as part of the "wake up messages" when the **CAL** message is seen you can release the button. Move to step 2 below.



2. When the "wake up" messages have finished and the display has settled down to its normal reading press, then release the **F** button. Move to step 3 below.

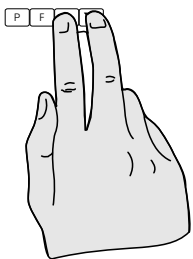

3. Within 2 seconds of releasing the **F** button press, then release the **▲** and **▼** buttons together. The display will now indicate **FUNC** followed by the first function.

Note: If step 1 above has been completed then the instrument will remain in this **CAL** mode state until power is removed. i.e. there is no need to repeat step 1 when accessing function unless power has been removed.

Entering **FUNC** Mode





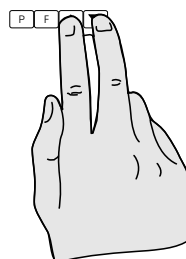

No special power up procedure is required to enter **FUNC** mode.









1. When the "wake up" messages have finished and the display has settled down to its normal reading press, then release the **F** button.



2. Within 2 seconds of releasing the **F** button press, then release the **▲** and **▼** buttons together. The display will now indicate **FUNC** followed by the first function.

Function	Description
chs	<p>Auto/Manual selection in function mode - see also Chapter 7 “Auto/Manual operation”.</p> <p>Allows selection between Auto (Auto i.e. direct transfer between input and output) and LOCAL (local i.e. Manual mode). At the chs function use the  or  pushbuttons to select Auto or LOCAL. Once the required selection is made press the  button to save the selection. When changing from Auto to Manual, the Manual value is set to the current Auto value thus achieving a bumpless transfer function. When changing from Manual to Auto, the Manual output will ramp towards the Auto value at a programmable rate (see delay function).</p> <p>Notes: The chs function will not be seen unless the first FN function (shown below) is set to chg.</p> <p>When entering the functions below ensure that you do not accidentally alter the chs setting, continue by pressing the  button to step through the functions.</p>
FN	<p>Select operation of external input (e.g. external switch or relay between EXT IN and GND, terminals 7 & 8) - see also Chapter 7 “Auto/Manual operation”.</p> <p>This function can be set to either OFF, ON or chg and determines what external input operation is required to switch from Auto to Manual or vice versa.</p> <p>If set to OFF the unit will be in the Auto mode when the external input is open and will be in Manual mode when the external input contacts are closed.</p> <p>If set to ON the unit will be in the Auto mode whilst the external input is closed and will be in Manual mode when the external input contacts are open.</p> <p>If set to chg the unit will toggle from Auto to Manual or vice versa every time the external input is closed (momentary action).</p> <p>Notes: If this function is set to OFF or ON then the chs function will not be available.</p> <p>There is a second FN function described later in this chapter, this second function must be set to NONE if the OFF, ON or chg operations described above are to be used.</p>
RLY1	<p>Select operation of relay 1.</p> <p>This function can be set to either AL or ctrl. When set to AL normal alarm operation as described in this chapter can be followed e.g. high and low setpoints. Selecting ctrl gives Auto/Manual mode indication via the relay open or closed state. In this mode Alarm relay 1 will be de-energised (open contacts) when the instrument is in the Auto mode and energised (closed contacts) in the Manual mode.</p> <p>Notes: If this function is set to ctrl the Alarm 1 setpoint functions will not be accessible. You may select AINO or AINC to change the relay contact status as required (i.e. change to open contacts indicating Manual and closed contacts indicating Auto). To change the status it will be necessary to temporarily set RLY1 to AL, enter FUNC mode and select AINO or AINC as required, once selected set RLY1 back to ctrl.</p> <p>The A1 alarm annunciator does not operate when the RLY1 function is set to ctrl but the Auto/Manual lights will change when the mode changes.</p>
ALo	<p>Alarm 1 relay low setpoint - seen only if RLY1 set to AL. Operates in both Auto and Manual mode.</p> <p>Displays and sets the alarm 1 relay low setpoint value. If a low alarm setpoint is not required it can be disabled by pressing the  and  pushbuttons simultaneously. When the alarm is disabled the display will indicate OFF. Alarm 1 relay will trip when the displayed value is equal to or lower than the ALo setpoint value.</p>

A 1H,	<p>Alarm 1 relay high setpoint - seen only if rLY 1 set to AL. Operates in both Auto and Manual mode.</p> <p>Displays and sets the alarm 1 relay high setpoint value. If a high alarm setpoint is not required it can be disabled by pressing the  and  pushbuttons simultaneously. When the alarm is disabled the display will indicate OFF. Alarm 1 will trip when the displayed value is equal to or higher than the A 1H, setpoint value.</p>
A2Lo, A3Lo, A4Lo	<p>Alarm 2, 3 & 4 relay low setpoint. Operates in both Auto and Manual mode.</p> <p>Displays and sets the optional alarm relays low setpoint value. If a low alarm setpoint is not required it can be disabled by pressing the  and  pushbuttons simultaneously. When the alarm is disabled the display will indicate OFF. The selected alarm relay will trip when the displayed value is equal to or lower than the low setpoint value.</p>
A2H, A3H, A4H,	<p>Alarm 2, 3 & 4 relay high setpoint. Operates in both Auto and Manual mode.</p> <p>Displays and sets the optional alarm relays high setpoint value. If a high alarm setpoint is not required it can be disabled by pressing the  and  pushbuttons simultaneously. When the alarm is disabled the display will indicate OFF. The selected alarm relay will trip when the displayed value is equal to or higher than the low setpoint value.</p>
A 1HY	<p>Alarm 1 relay hysteresis [deadband] - seen only if rLY 1 set to AL.</p> <p>Displays and sets the alarm 1 relay hysteresis limit and is common for both high and low setpoint values. In the high alarm mode once the alarm is tripped the input must fall below the setpoint value minus the hysteresis value to reset the alarm. In the low alarm mode once the alarm is tripped the input must rise above the setpoint value plus the hysteresis value to reset the alarm. The hysteresis units are expressed in displayed engineering units.</p>
A2HY, A3HY, A4HY	<p>Alarm 2, 3 & 4 relay hysteresis [deadband].</p> <p>Displays and sets the optional alarm 2, 3 & 4 hysteresis limit (as per A 1HY).</p>
A 1tE	<p>Alarm 1 relay trip time - seen only if rLY 1 set to AL.</p> <p>Displays and sets the alarm 1 trip time and is common for both alarm 1 high and low setpoint values. The trip time is the delay before the alarm will trip. The alarm condition must be present continuously for the trip time period before the alarm will trip. This function is useful for preventing an alarm trip due to short non critical deviations from setpoint. The trip time is selectable over 0 to 60 seconds.</p>
A2tE, A3tE, A4tE	<p>Alarm 2, 3 & 4 relay trip time.</p> <p>Displays and sets the optional alarm 2, 3 & 4 trip time (as per A 1tE).</p>
A 1n.o or A 1n.c	<p>Alarm 1 relay normally open or normally closed - seen only if rLY 1 set to AL</p> <p>Displays and sets the alarm relay 1 action to normally open (de-energised) or normally closed (energised), when no alarm condition is present.</p>
A2n.o or A2n.c A3n.o or A3n.c A4n.o or A4n.c	<p>Alarm 2, 3 & 4 relay normally open or normally closed.</p> <p>Displays and sets the optional alarm relay 2, 3 & 4 action to normally open (de-energised) or normally closed (energised), when no alarm condition is present.</p>

A2.SP or **A2.t** etc.

Relay operation independent setpoint or trailing setpoint - each alarm may be programmed to operate with an independent setpoint setting or may be linked (or trailing) to operate at a fixed difference to another relay setpoint. The operation is as follows:

Alarm 1 (**A1**) is always independent. Alarm 2 (**A2**) may be independent or may be linked to Alarm 1. Alarm 3 (**A3**) may be independent or may be linked to Alarm 1 or Alarm 2. Alarm 4 (**A4**) may be independent or may be linked to Alarm 1, Alarm 2 or Alarm 3. The operation of each alarm is selectable within the Function Setup Mode by selecting, for example, (Alarm 4) **A4.SP** = Alarm 4 normal setpoint or **A4.t 1** = Alarm 4 trailing Alarm 1 or **A4.t 2** = Alarm 4 trailing Alarm 2 or **A4.t 3** = Alarm 4 trailing Alarm 3. For trailing set points the setpoint value is entered as the difference from the setpoint being trailed. If the trailing setpoint is to operate ahead of the prime setpoint then the value is entered as a positive number and if operating behind the prime setpoint then the value is entered as a negative number. For example, with Alarm 2 set to trail alarm 1, if **A1.H** is set to 1000 and **A2.H** is set to 50 then Alarm 1 will activate at 1000 and alarm 2 will activate at 1050 (i.e. 1000 + 50). If Alarm 2 had been set at -50 then alarm 2 would activate at 950 (i.e. 1000 - 50). See the trailing alarm table which follows.

Note: trailing alarm relay 1 will not operate if **RLY 1** function is set to **ctrl** (control).

Trailing Alarm Table Showing Possible Alarm Assignments			
	A2	A3	A4
A1	A2.t 1	A3.t 1	A4.t 1
A2		A3.t 2	A4.t 2
A3			A4.t 3

BAR -

Bar graph display low value - seen only in bargraph display instruments.

Displays and sets the graph low value i.e. the value on the 7 segment display at which the bargraph will start to rise. This may be independently set anywhere within the display range of the instrument.



Note: The **BAR -** and **BAR +** settings are referenced from the 7 segment display readings, not the bargraph scale values. The bargraph scale may be scaled differently to the 7 segment display, as shown on the right where bargraph scale is 0 to 100 yet the display is showing **675.3**. In this example the bargraph scale may be indicating percentage fill of a tank whilst the 7 segment display is indicating actual process units.

The bargraph is available as a 20 segment straight bar or 16 segment circular bargraph

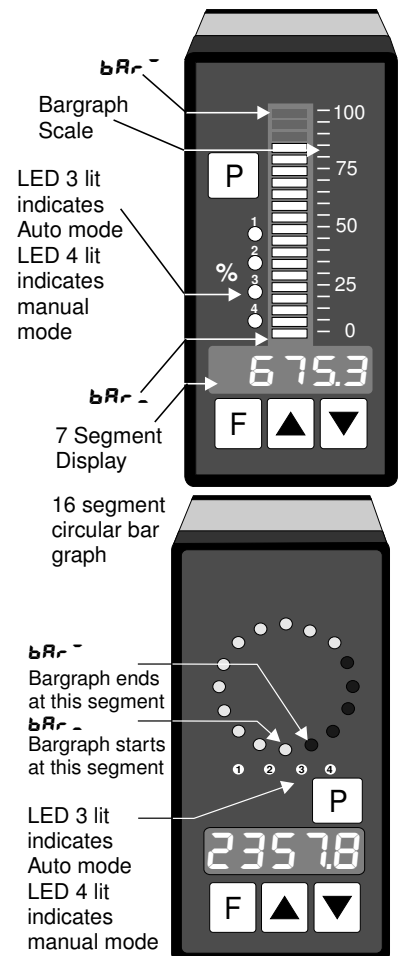
See the **BAR TYPE** function which follows for bargraph operation modes.



bAr[~]	<p>Bargraph display high value - seen only in bargraph display instruments.</p> <p>Displays and sets the bar graph high value i.e. the value on the 7 segment display at which the bargraph will reach its maximum indication (all LED's illuminated). May be independently set anywhere within the display range of the instrument.</p>
bAr TYPE	<p>Bar graph display operation mode - seen only in bargraph display instruments.</p> <p>Allows selection of bargraph operation mode choices are:</p> <p>bAr - conventional solid bargraph display i.e. all LED's illuminated when at full scale. e.g. when scaling the display use the bAr₋ and bAr[~] functions e.g. bAr₋ = 0 and bAr[~] = 100 will give a bargraph with no segments lit at a 7 segment display reading of 0 and all segments lit with a 7 segment display reading of 100.</p> <p>S.dot - single dot display. A single segment will be lit to indicate the input readings position on the scale. e.g. when scaling the display use the bAr₋ and bAr[~] functions e.g. bAr₋ = 0 and bAr[~] = 100 will give a bargraph with the bottom segment lit at a 7 segment display reading of 0 and the top segment lit with a 7 segment display reading of 100.</p> <p>Note: this could also be set up as a centre zero single dot display by entering a negative value and positive value. e.g. bAr₋ = -100, bAr[~] = 100.</p> <p>d.dot - double dot display. Two segments will be lit to indicate the input reading position on the scale. The reading should be taken from the middle of the two segments. e.g. when scaling the display use the bAr₋ and bAr[~] functions e.g. bAr₋ = 0 and bAr[~] = 100 will give a bargraph with the bottom two segments lit at a 7 segment display reading of 0 and the top two segments lit with a 7 segment display reading of 100.</p> <p>Note: this could also be set up as a centre zero single dot display by entering a negative value and positive value. e.g. bAr₋ = -100, bAr[~] = 100.</p> <p>C.bAr - centre bar display. The display will be a solid bargraph but will have its zero point in the middle of the display. If the seven segment display value is positive the bargraph will rise. If the seven segment display value is negative then the bargraph will fall. e.g. when scaling the display use the bAr₋ and bAr[~] functions e.g. bAr₋ = 0 and bAr[~] = 100 will give a bargraph with all the bottom half segments lit at a 7 segment display reading of -100 and all the top segments lit with a 7 segment display reading of 100.</p>
P.SET	<p>Preset value - a preset value can be entered at this function. If the remote input (F.I NP function) or P button (P.but function) is programmed to P.SET then operation of the remote input or P button will cause the display to change to the preset value. Any change in input from this point will cause a variation above or below the preset value. For example with a display showing a value of 50 at a 12mA input if the P.SET function is set to 70 and the remote function is set to P.SET then once the remote input is operated an input of 12mA will now have a display value of 70.</p>
br9t	<p>Display brightness.</p> <p>Displays and sets the digital display brightness. The display brightness is selectable from 1 to 15, where 1 = lowest intensity and 15 = highest intensity. This function is useful for improving the display readability in dark areas or to reduce the power consumption of the instrument.</p>
dULL	<p>External/remote input display brightness.</p> <p>Displays and sets the level for remote input brightness switching, see F.I NP function. When the remote input is set to dULL the remote input can be used to switch between the display brightness level set by the br9t function and the display brightness set by the dULL function. The display brightness is selectable from 0 to 15, where 0 = lowest intensity and 15 = highest intensity. This function is useful in reducing glare when the display needs to be viewed in both light and dark ambient light levels.</p>

rEE-	<p>Analog retransmission output low value.</p> <p>Displays and sets the analog retransmission (4 to 20mA, 0-1V or 0-10V) output low value (4mA or 0V) in displayed engineering units.</p> <p>For example to obtain a 4mA retransmission when the display value is 0.0 set the rEE- function to 0.0.</p>
rEE+	<p>Analog retransmission output high value.</p> <p>Displays and sets the analog retransmission (4 to 20mA, 0-1V or 0-10V) output high value (20mA, 1V or 10V) in displayed engineering units. For example to obtain a 20mA retransmission when the display value is 50.0 set the rEE+ function to 50.0.</p>
rEE dLAY	<p>Manual to Auto ramp delay.</p> <p>Sets the delay time for the Manual to Auto ramp (1 to 9999 seconds). This sets the time it will take to ramp over the entire retransmission output range. For example if set to 30 it would take 30 seconds for the retransmission to change from 4mA to 20mA when switched from Manual to Auto operation.</p>
drnd	<p>Display rounding.</p> <p>Displays and sets the display rounding value. This value may be set to 1 - 5000 displayed units. Display rounding is useful for reducing the instrument resolution without loss of accuracy, in applications where it is undesirable to display to a fine tolerance. For example if set to 10 the instrument will display only in multiples of 10). Note that this function operates in Auto mode only i.e. there is no display rounding when the pushbuttons are used to vary the output.</p>
dCPE	<p>Decimal point selection.</p> <p>Displays and sets the decimal point position. By pressing the  or  pushbuttons the decimal point position may be set. The display will indicate as follows: 0 (no decimal point), 0. 1 (1 decimal place), 0.02 (2 decimal places), 0.003 (3 decimal places).</p>
FLtr	<p>Digital filter.</p> <p>Displays and sets the digital filter value. Digital filtering is used for reducing susceptibility to short term interference. The digital filter range is selectable from 0 to 8, where 0 = none and 8 = most filtering. A typical value for the digital filter would be 3.</p>
di SP unit	<p>Display unit.</p> <p>Certain display unit characters can be selected if required, to display temperature units. Choices are:</p> <p>none i.e. no display units e.g. 2345 °C e.g. 45°C °F e.g. 18°F ° e.g. 123° °C e.g. 45.3°C °F e.g. 23.7°F</p> <p>Note that when a display unit is chosen it will take up one or two of the available display digits, this may limit the maximum or minimum value which can be displayed. If the number becomes too large to display then an error message -err- will appear on the display.</p>

CAL 1

First scaling point for 2 point scaling method.

CAL 1/SCL 1 and **CAL 2/SCL 2** are used together to scale the instruments display, values for both must be set when using this scaling method (**USER En 4** and **USER En 20** functions can be used as an alternative method of scaling when the input is 4-20mA and scaling without a live input is required).

The **CAL 1** function sets the first calibration point for live input calibration. When using this method a signal input must be present at the input terminals. Note: **CAL 1** and **CAL 2** can be set independently.

The procedure for entering the first scaling point is:

- a. Ensure that an input signal is present at the input terminals, this will usually be at the low end of the signal range e.g. 4mA for a 4-20mA input.
- b. At the **CAL 1** function press **▲** and **▼** simultaneously then release them. The display will indicate the live input value. Do not be concerned at this stage if the live input display value is not what is required. It is important that the live input value seen is a steady value, if not then the input needs to be investigated before proceeding with the scaling.
- c. Press, then release the **F** button. The display will indicate **SCL 1** followed by a value. Use the **▲** or **▼** button to change this value to the required display value at this input. e.g. if 4mA was input and the required display at 4mA was **0** then ensure **0** is selected at **SCL 1**. Press the **F** button to accept changes or the **P** button to abort the scaling.

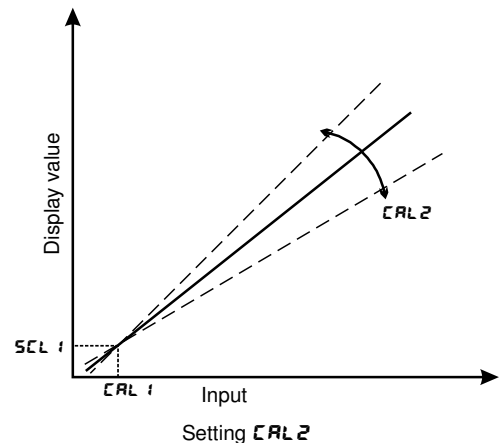
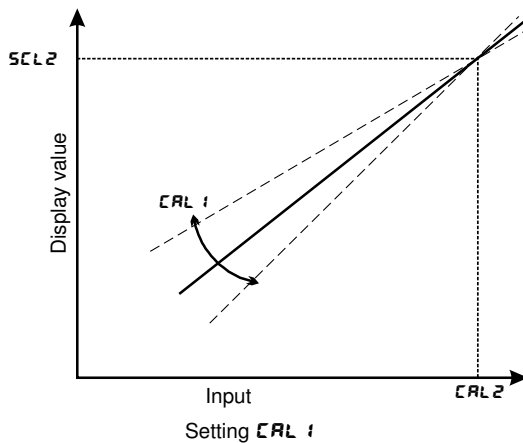

CAL 2

Second scaling point for 2 point scaling method.

The procedure for entering the second scaling point is:

a. Ensure that an input signal is present at the input terminals, this will usually be at the high end of the signal range e.g. 20mA for a 4-20mA input.

b. At the **CAL 2** function press **▲** and **▼** simultaneously then release them. The display will indicate the live input value. Do not be concerned at this stage if the live input display value is not what is required. It is important that the live input value seen is a steady value, if not then the input needs to be investigated before proceeding with the scaling.

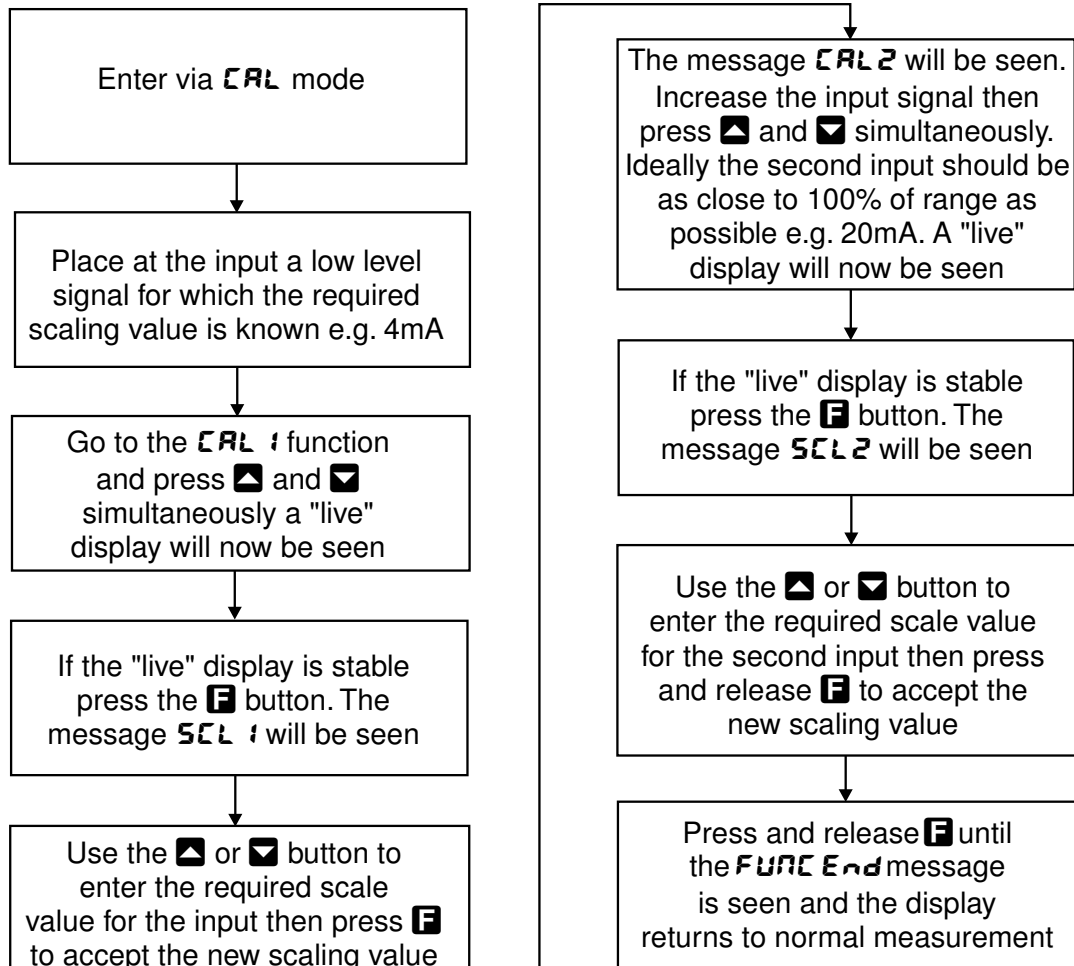

c. Press, then release the **F** button. The display will indicate **SCL 2** followed by a value. Use the **▲** or **▼** button to change this value to the required display value at this input. e.g. if 20mA was input and the required display at 20mA was **100** then ensure **100** is selected at **SCL 1**. Press the **F** button to accept changes or the **P** button to abort the scaling.

Note: it is not essential that 4 and 20mA are used as the live inputs for a 4-20mA scaling but there must be at least a 10% of full scale difference between the **CAL 1** and **CAL 2** inputs, if this is not the case then a **SPAN Err** message will be seen and the calibration point will not be accepted.

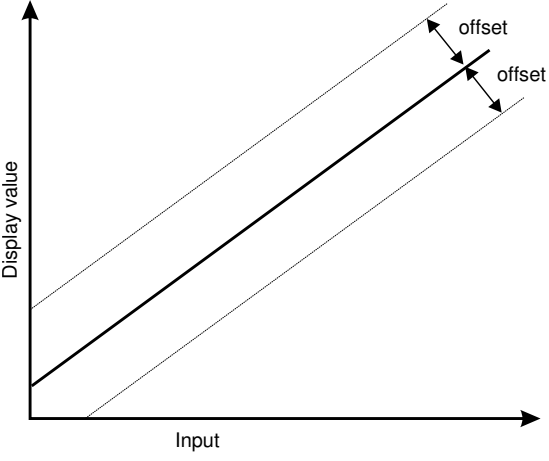

Note: If the "live" display at any scaling point is not stable then check the input signal for stability.

<p>CAL OFSt</p>	<p>Calibration offset - the calibration offset is a single point adjustment which can be used to alter the calibration scaling values across the entire measuring range without affecting the calibration slope. This method can be used instead of performing a two point calibration when a constant measurement error is found to exist across the entire range. To perform a calibration offset press the ▲ and ▼ buttons simultaneously at the CAL OFSt function. A "live" reading from the input will be seen, make a note of this reading. Press the ■ button, the message SCLE will now be seen followed by the last scale value in memory. Use the ▲ or ▼ button to adjust the scale value to the required display value for that input. For example if the "live" input reading was 50 and the required display value for this input was 70 then adjust the SCLE value to 70.</p>	
<p>ZERO RNGE</p>	<p>Zero range - the zero range function allows a limit value to be set (in engineering units) above which the display will not zero i.e. if a zero operation is attempted via the ■ button, remote input or set zero function when the display value is greater than the zero range setting the display will refuse to zero and give a ZERO RNGE Err message (note that the CAL OFSt function is also affected by the ZERO RNGE setting). For example if the zero range setting is 10 the instrument will only respond to a zero operation if the display reading at the time is between -10 and 10. If the zero range function is not required it can be set to OFF by pressing the ▲ and ▼ buttons simultaneously at this function. When switched off the instrument can be zeroed no matter what the display value.</p> <p>Note that the instrument keeps track of the value being zeroed at each operation, when the total amount zeroed from repeated operations becomes greater than the zero range value the instrument will reject the zero operation and a ZERO RNGE Err message will be seen. To allow a zero operation beyond this point either the ZERO RNGE function value will need to be raised or a new zero reference point introduced via the CAL ZERO function.</p> <p>If repeated zero operations are required the ZERO RNGE function should be set to OFF or alternatively the LRNGE operation could be considered.</p>	
<p>CAL ZERO</p>	<p>Calibration zero - the calibration zero function is used following a calibration via CAL 1 and CAL 2. A calibration zero operation at this time ensures that the display zero and the ZERO RNGE reference zero are at the same point after a calibration. After a calibration the calibration zero can also be used to select a zero point other than the display zero as the reference for the ZERO RNGE function. For example if the CAL ZERO operation is carried out with a display reading of 500 and a ZERO RNGE reading of 10 the zero range function will allow the display to zero only if the current display reading is between 490 and 510. To perform a calibration zero press the ▲ and ▼ buttons simultaneously at the CAL ZERO function, a live reading will be seen, press the ■ button, the message CAL ZERO End should now be seen indicating that the instrument has accepted the zero point. Although the display reading will not change as a result of the calibration zero the input value on the display at the time of the operation will be the new zero reference point for the ZERO RNGE function.</p>	
<p>USER En4</p>	<p>4mA input scaling without a live input.</p> <p>This scaling method can be used with 4-20mA inputs only. The instrument can be scaled for a 4-20mA input without a live input i.e. this is an alternative method to the CAL 1 and CAL 2 method of scaling. To perform the first point (USER En4) scaling simply press the ▲ and ▼ buttons simultaneously when the USER En4 function has been reached. The display will now indicate a value. Use the ▲ or ▼ button to change this value to the display value required for a 4mA input.</p>	

USEF En20	<p>20mA input scaling without a live input.</p> <p>This scaling method can be used with 4-20mA inputs only. The same method described in USEF En4 above can be used to scale the instrument for the display value required for a 20mA input.</p>
UCAL	<p>Uncalibration.</p> <p>Used to set the instrument back to the factory calibration values. This function should only be used when calibration problems exist, and it is necessary to clear the calibration memory. To clear the memory press the  and  buttons simultaneously at the UCAL functions. The message CAL CLR will be seen to indicate that the memory has cleared.</p>
P.but	<p>P button function - Applicable only in models with front panel P buttons. The P button functions other than LSLE operate on the Auto input only e.g. you can zero an Auto display value but cannot use the P button to zero a manually set value.</p> <p>The P button may be set to operate some of the remote input functions, see F:RP below for a description of these functions. The P button is located at the front of 5 or 6 digit LED models (see page 3 for location of this button on the bargraph model). If both the remote input and P button function are operated simultaneously the P button will override the remote input. The functions below are as described in the F:RP function below.</p> <p>Functions available are: NONE, Hi, Lo, Hi, Lo, LARF, ZERO, P.SET or LSLE</p> <p>Notes: To prevent accidental operation of the P button in the LARF or ZERO functions it is necessary to hold the button in for 2 seconds to perform the selected operation.</p> <p>To use the P button to toggle between Auto and Manual operation the first F:RP function must be set to LSI and the second F:RP function (described below) set to NONE.</p>

Remote input/external input function. Terminals 7 and 8 at the rear of the instrument are the remote input/external input terminals. When these terminals are short circuited, via a pushbutton or keyswitch the instrument will perform the selected remote input function. A message will flash to indicate which function has been selected when the remote input terminals are short circuited. The remote input only operates in Auto mode e.g. you can zero a display in Auto mode but cannot use the remote input to zero a manually set value. The remote input functions are as follows:

NONE - use this setting when the remote input is required to toggle between Auto & Manual - see page 10 description of the first **REMOTE INPUT (ON/OFF/LOG)** function.

PHLD - peak hold. The display will show the peak value only whilst the remote input terminals are short circuited.

d.HLD - display hold. The display value will be held whilst the remote input terminals are short circuited.

M - peak memory. The peak value stored in memory will be displayed if the remote input terminals are short circuited, if the short circuit is momentary then the display will return to normal measurement after 20 seconds. If the short circuit is held for 1 to 2 seconds or the power is removed from the instrument then the memory will be reset.

Lo - valley memory. The minimum value stored in memory will be displayed. Otherwise operates in the same manner as the **M** function.

M, Lo - toggle between **M** and **Lo** displays. This function allows the remote input to be used to toggle between peak and valley memory displays. The first operation of the remote input will cause the peak memory value to be displayed, the next operation will give a valley memory display. **PH** or **PLo** will flash before each display to give an indication of display type.

TARE - display tare. Short circuiting the remote input terminals momentarily will allow toggling between nett and gross values (shown as **NETT** and **GROSS**). If the remote input is short circuited for approx. 2 seconds the display will be tared and will show zero. The tare will be lost if power is removed.

ZERO - display zero. Zeroes the display in same manner as the tare function except that the zero is not lost when power is removed and the display will zero as soon as the remote input is short circuited.

SP.AC - setpoint access only. This blocks access to any functions except the alarm setpoint functions unless the remote input terminals are short circuited or entry is made via **CAL** mode.



NO.AC - no access. This blocks access to all functions unless the remote input terminals are short circuited or entry is made via **CAL** mode.

CAL.S - calibration select. The remote input can be used to select between calibration scaling values. Two sets of calibration values can be entered in the PM4, one set with the remote input open circuit and another set with the remote input short circuit to ground. The remote input can then be used to switch between one set and the other. This feature can be used on all input ranges. For example: With the remote input open circuit a 4-20mA input can be scaled (using **CAL 1 & CAL 2** or **USER EN4** and **USER EN20**) to read 0 to 100 over the 4-20mA range. With the remote input short circuit to ground the scaling can be repeated using figures of 0 to 500 for the 4-20mA range. The remote input can be used to switch between ranges. In this example the first scaling could represent a % figure and the second scaling could represent the actual process units (litres, kg, volts etc). **Note:** Only one set of alarm functions can be made and the alarm relay will operate from those set values no matter which calibration scale is being viewed at the time.

P.SET - preset. The remote input can be used to force the display to a preset value set at the **P.SET** function.

dULL - display brightness control. The remote input can be used to change the display brightness. When this mode is selected the display brightness can be switched, via the remote input, between the brightness level set at the **brgt** function and the brightness level set at the **dULL** function.

ACCESS	Access mode - the access mode function ACCESS has four possible settings namely OFF , EASY , NONE and ALL . If set to OFF the mode function has no effect on alarm relay operation. If set to EASY the easy alarm access mode will be activated, see details at the beginning of this chapter preceding the ALLO function. If set to NONE there will be no access to any functions via FUNC mode, entry via CAL mode must be made to gain access to alarm and calibration functions. If set to ALL then access to all functions, including calibration functions, can be gained via FUNC mode.
SPAC	Setpoint access. Seen only if more than 1 relay fitted. Sets the FUNC mode access to the alarm relay set points. The following choices are available: R 1 - Allows setpoint access to alarm 1 only. R 1-2 - Allows access to alarms 1 and 2.
Sqr t	Square root. Operates on Auto display & output only. Selects the square root scaling to on or OFF . When set to on a square root function is applied to the input. When set to OFF the calibration is a linear function. Note: It is essential that the display is rescaled, using CAL 1 and CAL 2 or USER En 4 and USER En 20 , whenever this function is turned on or off. When the square root facility is used the scaled displayed value follows the square root of the percentage of the full scale input value. The upper and lower input limits are set as normal as are the values to be displayed at these limits. For example if, for a 4 - 20mA input, you wish to display 0 at 4mA and 1000 at 20mA the square root function will calculate as follows: At 20mA (100%) the display will be 1000 i.e. .At 16mA (75%) the display will be 866 i.e. At 12mA (50%) the display will be 707 i.e. and so on.
R 1 & R 2	Alarm relay operation mode for relays 1 and 2. The following choices are available for alarm operation mode: L, UE - live input mode. The alarm relay operation will always follow the electrical input at that time irrespective of the 7 segment display value. e.g. assume the remote input is set to LRFE and R 1H is set to 100 . If the instrument is tared at a display reading of 30 then the alarm will now activate at a display reading of 70. LRFE - tare mode. The alarm relay operation will follow the tare function. e.g. in the example above (d: SP) if R 1 is set to LRFE then the alarm would activate at a display reading of 100 (the setpoint value) rather than 70. P.HLd - peak hold mode. If the peak hold mode is used and the remote input is set to peak hold then once the peak display goes above any alarm high setpoint the alarm relay will activate and will not de-activate until the peak hold is released and the display value falls below the setpoint value. d.HLd - display hold mode. If the display hold mode is used and the remote input is set to display hold then the alarm relay will be held in its present state (activated or de-activated) until the display hold is released and the display is free to change. H - peak (max.) memory mode. If the peak memory mode is used and the remote input is set to peak memory then the alarm will be activated if the peak memory value is above the high setpoint value. The alarm will not de-activate until the memory is reset. Lo - valley (min.) memory mode. If the valley memory mode is used and the remote input is set to valley memory then the alarm relay will be activated if the valley memory value is below the low setpoint value. The alarm will not de-activate until the memory is reset. d: SP - display mode. If the live display mode is used then the alarms will operate purely on the display value at the time i.e. if the display is showing above high setpoint or below the low setpoint value then the alarm relay will activate. For example if the remote input were set to peak memory and R 1 were set to L, UE display mode then, unless the display is actually showing the peak memory value (i.e. the remote input has just been activated), the alarm relay is free to operate from the changing display value i.e. the memory does not have to be reset to clear an alarm condition.

<p>bARF</p>	<p>Bargraph operation mode - applicable only to bargraph displays.</p> <p>The following choices are available for bargraph operation mode:</p> <p>L, UE - live input mode. The bargraph will respond to the electrical input only and will not necessarily follow the 7 segment display value. For example if the remote input is set for peak hold operation then when the remote input is closed the 7 segment display will only show the peak value but the bargraph will be free to move up and down to follow the electrical input.</p> <p>TRFE - tare mode. The bargraph will tare (fall to zero) along with 7 segment display when the remote input tare function is operated. If the remote input toggles the 7 segment display to show gross (9FOS) then the 7 segment display will change to show the gross value but the bargraph will not respond (see L, UE for alternative operation).</p> <p>P.HLd - peak hold mode. The bargraph (and 7 segment display) will indicate the peak value only whilst the peak value function is operated via a contact closure on the remote input i.e. the bargraph & 7 segment display can rise but not fall whilst the remote input switch is closed. When the remote input switch is opened the bargraph value will remain fixed i.e. it will not rise or fall, although the 7 segment display value will be free to alter. This peak bargraph reading can be cleared by closing the remote input switch for another operation or by removing power from the instrument. Note: In this mode the bargraph will show a zero reading until the remote input is operated for the first time after switch on.</p> <p>d.HLd - display hold mode. The bargraph (and 7 segment display) value will be held whilst the remote input display hold switch is closed. When the switch is opened the bargraph value will remain fixed at the held value although the 7 segment display value will be free to alter. The held bargraph reading can be cleared by closing the remote input switch for another operation or by removing power from the instrument. Note: In this mode the bargraph will show a zero reading until the remote input is operated for the first time after switch on.</p> <p>H - peak (max.) memory mode. With the peak remote input switch open the bargraph will indicate the peak value in memory i.e. the bargraph can rise but not fall. The bargraph can be reset by clearing the memory. The memory may be cleared either by closing the remote input switch for approximately 2 seconds or by removing power to the instrument.</p> <p>Lo - valley (min.) memory mode. With the valley remote input switch open the bargraph will indicate the valley (min.) value in memory i.e. the bargraph can fall but not rise. The bargraph can be reset by clearing the memory. The memory may be cleared either by closing the remote input switch for approximately 2 seconds or by removing power to the instrument.</p> <p>d: SP - display mode. The bargraph display will follow whatever value is on the 7 segment display. For example if the remote input is to TRFE then the 7 segment and bargraph will indicate the tared value and both will also be changed if the remote input toggles the displays between nEtt and 9FOS. If the bARF function had been set to TRFE then the bargraph would not respond to the 9FOS toggle.</p>
<p>Lo d: SP</p>	<p>Low overrange limit value - the display can be set to show an overrange message if the display value falls below the Lo d: SP setting. For example if Lo d: SP is set to 50 then once the display reading falls below 50 the message -or- or the display value (see d: SP function) will flash instead of the normal display units. This message can be used to alert operators to the presence of an input which is below the low limit. If this function is not required it should be set to OFF by pressing the  and  buttons simultaneously at this function.</p>
<p>H: 9H d: SP</p>	<p>High overrange limit value - the display can be set to show an overrange message if the display value rises above the H: 9H d: SP setting. For example if H: 9H d: SP is set to 1000 then once the display reading rises above 1000 the message -or- or the display value (see d: SP function) will flash instead of the normal display units. This message can be used to alert operators to the presence of an input which is above the high limit. If this function is not required it should be set to OFF.</p>

d: SP	<p>Display overrange warning flashing mode - this function is used in conjunction with the Lo and Hi GH d: SP functions. The d: SP function can be set to FLASH or -or-. If the value set at the Lo or Hi GH d: SP function is exceeded and the d: SP function is set to FLASH then the display value will flash on for approximately one second and off for approximately one second as a warning. If the value set at the Lo or Hi GH d: SP function is exceeded and the d: SP function is set to -or- then the -or- message will flash on for approximately one second and off for approximately one second as a warning. The warning flashes will cease and the normal display value will be seen when the value displayed is higher than the low limit and lower than the high limit.</p>
--------------	--

Returning to the normal measure mode

When the calibration procedure has been completed it is advisable to return the instrument to the normal mode (where calibration functions cannot be tampered with). To return to the normal mode, turn off power to the instrument, wait a few seconds and then restore power.

6 Function table

Initial display	Meaning of display	Next display	Default Settings	Record Your Settings
chn9	Change between Auto & Manual	Auto or LCAL (Manual)	Auto	
r.i.np	Select remote input function	OFF , ON or to9i (accessible via CAL mode)	OFF	
rLY1	Alarm 1 relay operation	RL or ctrl (accessible via CAL mode)	RL	
R1Lo	Alarm 1 low setpoint value	Setpoint value or OFF	OFF	See following table
R1Hi	Alarm 1 high setpoint value	Setpoint value or OFF	OFF	See following table
R2Lo etc.	Alarm 2, 3 etc. low setpoint value	Setpoint value or OFF	OFF	See following table
R2Hi etc.	Alarm 2 high setpoint value	Setpoint value or OFF	OFF	See following table
R1HY	Alarm 1 hysteresis	Hysteresis value in measured units	10	See following table
R2HY etc.	Alarm 2, 3 etc. hysteresis	Hysteresis value in measured units	10	See following table
R1tt	Alarm 1 trip time	No of seconds before relay 1 trips	0	See following table
R2tt etc.	Alarm 2, 3 etc. trip time	No of seconds before relay 2 trips	0	See following table
R1n.o or R1n.c	Alarm 1 action N/O or N/C	R1n.o or R1n.c	R1n.o	See following table
R2n.o or R2n.c etc.	Alarm 2, 3 etc action N/O or N/C	R2n.o or R2n.c	R2n.o	See following table
R2.SP or R2.tl etc.	Setpoint or trailing alarm	R2.SP or R2.tl	R2.SP	See following table
bAr-	Bargraph low reading	Value in memory	0	
bAr+	Bargraph high reading	Value in memory	1000	
bAr TYPE	Bargraph operation mode	bAr .S.dot.d.dot or C.bAr	bAr	
P.SET	Preset value	Value in memory	0	
brgt	Display brightness	1 to 15	15	
dULL	Remote display brightness switching	0 to 15	1	
rEC-	Retransmission output low limit	Value in memory	0	
rEC+	Retransmission output high limit	Value in memory	1000	
Functions below are accessible only via CAL mode or if ACC5 function is set to ALL				
rEC dLAY	Manual ramping delay time	0 to 9999 seconds	0	
drnd	Display rounding selects resolution	Value in memory	1	
dCPt	Display decimal point	Decimal point position (e.g. 0.1 or 0.02)	0	
FLtr	Digital filter range 0 to 8	0 to 8 (8 =most filtering)	2	
di SP un.t	Display units	NONE , PC , PF , P.C or F	NONE	
CAL 1 & CAL 2	Calibration scaling points	Value in memory	n/a	

Initial display	Meaning of display	Next display	Default Settings	Record Your Settings
<i>CAL OFFSE</i>	Offset to calibration	Live Reading	n/a	
<i>ZERO RANGE</i>	Zero range limit	Limit value or <i>OFF</i>	1000	
<i>CAL ZERO</i>	Zero point calibration	Value in memory	n/a	
<i>USER EN4</i>	4mA input scale	Value in memory	0	
<i>USER EN20</i>	20mA input scale	Value in memory	1000	
<i>UCAL</i>	Uncalibrate	<i>CAL CLR</i>	n/a	
<i>P.but</i>	P button function	<i>NONE .H. .Lo .H. Lo .tRGE . ZERO .P.SET or tGLE</i>	<i>NONE</i>	
<i>r.i NP</i>	Remote input function	<i>NONE .PHLd .dHLd .H. .Lo . H. Lo .tRGE .ZERO .SP.Ac . No.Ac .CAL.S .P.SET or duLL</i>	<i>NONE</i>	
<i>ACCESS</i>	Access mode	<i>OFF .EASY .NONE or ALL</i>	<i>OFF</i>	
<i>SPAC</i>	Setpoint access	<i>R 1 .R 1-2</i> etc.	<i>R 1</i>	
<i>SQRt</i>	Square root	<i>OFF or on</i>	<i>OFF</i>	
<i>R 1 .R 2</i> etc.	Alarm 1, 2 etc. operation mode	<i>L. uE .tRGE .P.HLd .d.HLd . H. .Lo or d! SP</i>	<i>L. uE</i>	See following table
<i>bAR</i>	Bargraph operation mode	<i>L. uE .tRGE .P.HLd .d.HLd . H. .Lo or d! SP</i>	<i>L. uE</i>	
<i>Lo d! SP</i>	Display low overrange	Limit value or <i>OFF</i>	<i>OFF</i>	
<i>Hi GH d! SP</i>	Display high overrange	Limit value or <i>OFF</i>	<i>OFF</i>	
<i>d! SP</i>	Overrange display warning flashing mode	<i>FLASH or -or -</i>	<i>FLASH</i>	

Note: Functions shown shaded on this table will be displayed, only when those particular options are fitted.

Settings for relays - record settings here				
	A1	A2	A3	A4
<i>RxLo</i>				
<i>RxHi</i>				
<i>RxHY</i>				
<i>Rxtt</i>				
<i>Rxr t</i>				
<i>Rxn.o</i> or <i>Rxn.c</i>				
<i>Rx.SP</i> or <i>Rx.t !</i>	n/a			
<i>Rx</i>				

7 Auto/Manual operation

Note: if power is removed the mode automatically reverts to Auto on reapplying power. There are three ways to change between Auto and Manual as follows:

1. Changing between Auto and Manual using an external switch.

The remote input (terminals 7 & 8) can be used via a switch to change between Auto and Manual. There are two functions, both named **F.I. NP** which affect the remote input operation. The second **F.I. NP** function is only accessible via **CAL** mode and must be set to **NONE** if the switch is to be used to change between Auto and Manual. The first **F.I. NP** is accessible via **FUNC** mode and has three settings namely:

F.I. NP set to **OFF**

External switch is open for Auto operation and closed for Manual

F.I. NP set to **on**

External switch is closed for Auto operation and open for Manual operation.

F.I. NP set to **to9!**

Press momentary (normally open) pushbutton or remote contact connected to remote input to toggle between Auto and Manual.

When the switch is operated the instrument will alternate between Auto and Manual. When changing from Auto to Manual, the Manual value is matched to the Auto value, creating a bumpless transfer - the front panel LED will indicate to "A4" (5 digit displays only, for bargraph displays light 4 will be lit). When changing from Manual to Auto, the output will ramp towards the incoming Auto value at a programmable rate (see **delay** function) - the front panel LED will indicate "A3" (5 digit displays only, for bargraph displays light 3 will be lit).

2. Changing between Auto and Manual via the front panel **P** button.

The function **P.but** may be set to **to9!** to allow the **P** button to be used to toggle between Auto and Manual. Note that the first **F.I. NP** function must be set to **to9!** and the second **F.I. NP** function must be set to **NONE** if the **P** button is used to toggle between Auto and Manual.

3. Changing between Auto and Manual in the function mode.

Enter the function mode by pressing the **F** button and then (within 2 seconds) press both the **▲** and **▼** pushbuttons simultaneously (as described in chapter "Explanation of Functions"). The display will indicate **Chng**, (indicating that the instrument may be changed between Auto and Manual). Select between **Auto** (Auto ie. direct transfer between input and output) and **LOCAL** (local i.e. Manual mode). By pressing the **▲** or **▼** pushbuttons the display will toggle between **Auto** & **LOCAL**. Pressing the **F** button will set the instrument to Auto or Manual. When changing from Auto to Manual, the Manual value is set to the current Auto value thus achieving a bumpless transfer function- the front panel LED will indicate "A4" (5 digit displays only, for bargraph displays light 4 will be lit). When changing from Manual to Auto, the Manual output will ramp to towards the Auto value at a programmable rate (see **delay** function) - the front panel LED will indicate "A3" (5 digit displays only, for bargraph displays light 3 will be lit).

Notes:- The **Chng** function will only be seen if the first **F.I. NP** function is set to **to9!**.

The Manual output is set in the same manner as a function value (i.e. alarms etc). Increment/decrement will start slowly then speed will increase while button is held. The retransmission output will update approximately 4 times per second. Note that if the **F** button is pressed the **▲** and **▼** buttons will be disabled for 2 seconds to enable the normal function mode to be entered if required.

The Manual output may only be set within the retransmission output limits, (ie if retransmission low is 400 and high is 2000 then the Manual lower limit is 400 and the high limit 2000). NB if the retransmission is set as 2000 - 400 (reverse output !) then the lower limit is still 400 and the upper limit 2000.

When changing from Manual to Auto mode the ramp rate is determined as followed:

$$\text{Change time} = \frac{\text{Auto display value} - \text{Manual display value}}{\text{FEC}^+ - \text{FEC}^-} \times \text{delay}$$

If the input is overranged then the ramp rate approximates the maximum delay time. If the input changes and either reaches or overtakes the ramping value then the ramp is cancelled and normal operation resumes.

When changing from Auto to Manual the Manual value is limited to the range specified above. i.e. if the input is overranged high and the unit is switched to **LOCAL** then the value displayed will be the retransmission high value.

8 Specifications

8.1 Technical Specifications

Input Types:	Link selectable 4 to 20mA, $\pm 20\text{mA}$, $\pm 2\text{mA}$ or DC Volts $\pm 100\text{mV}$, $\pm 1\text{V}$, $\pm 10\text{V}$ or $\pm 100\text{V}$ Slidewire, 3 wire 0-1k Ω to 0-1M Ω value slidewires or Manual input
Impedance:	80 Ω (4 to 20mA) & 1M Ω on DC Voltage
ADC Resolution:	1 in 20,000
Accuracy:	0.1% of full scale when calibrated except for $\pm 2\text{mA}$ and $\pm 100\text{mV}$ ranges which are 0.3% of full scale when calibrated (display and alarms)
Sample Rate:	4 per sec
Conversion Method:	Dual Slope ADC
Microprocessor:	MC68HC11 CMOS
Ambient Temperature:	-40 to 60 $^{\circ}\text{C}$
Humidity:	5 to 95% non condensing
Display:	5 digit 14.2mm + status LEDs + 4 way keypad. 20 segment bargraph + 5 digit 7.6 mm + 4 way keypad + alarm/mode LEDs 16 segment circular bargraph + 5 digit 7.6 mm + 4 way keypad + alarm/mode LEDs
Power Supply:	AC 240V, 110V or 24V 50/60Hz or DC isolated wide range 12 to 48V. Special supply types 32VAC, 48VAC 50/60Hz or DC isolated 50 to 110V also available. Note: supply type is factory configured.
Power Consumption:	AC supply 4 VA max, DC supply, consult supplier (depends on display type & options). Typical DC consumption for model PM4-AM-DC-5E is 100mA at 24V and 200mA at 12V, allow double these currents for switch on surge.
Output (standard):	1 x relay, Form A rated 5A resistive
Relay Action:	Programmable N.O. or N.C.
Analog Retransmission:	4 to 20mA standard (will drive into 800 Ω load maximum) 0 to 1V and 0 to 10V link selectable

8.2 Output Options

2nd Relay:	Same specs as Relay 1
2nd, 3rd & 4th Relay:	Form C rated 5A resistive
DC Voltage Output:	Isolated $\pm 12\text{V}(24\text{V})$ standard, $\pm 5\text{V}(10\text{V})$ link selectable (25mA maximum)

8.3 Physical Characteristics

Bezel Size:	DIN 48mm x 96mm x 10mm
Case Size:	44mm x 91mm x 120mm behind face of panel
Panel Cut Out:	45mm x 92mm +1mm &- 0mm
Connections:	Plug in screw terminals (max 1.5mm wire)
Weight:	400 gms Basic model, 450 gms with option card

9 Guarantee & service

The product supplied with this manual is guaranteed against faulty workmanship for a period of 2 years from the date of dispatch.

Our obligation assumed under this guarantee is limited to the replacement of parts which, by our examination, are proved to be defective and have not been misused, carelessly handled, defaced or damaged due to incorrect installation. This guarantee is VOID where the unit has been opened, tampered with or if repairs have been made or attempted by anyone except an authorised representative of the manufacturing company.

Products for attention under guarantee (unless otherwise agreed) **must be returned to the manufacturer freight paid** and, if accepted for free repair, will be returned to the customers address in Australia free of charge.

When returning the product for service or repair a full description of the fault and the mode of operation used when the product failed must be given.

In any event the manufacturer has no other obligation or liability beyond replacement or repair of this product.

Modifications may be made to any existing or future models of the unit as it may deem necessary without incurring any obligation to incorporate such modifications in units previously sold or to which this guarantee may relate.

**This document is the property of
the instrument manufacturer
and may not be reproduced in whole or part without the
written consent of the manufacturer.**

This product is designed and manufactured in Australia.