

# **LD-RTC**

Real Time Clock  
Large Digit Display

Operation and Instruction Manual

---

**AMALGAMATED INSTRUMENT CO PTY LTD**

ACN: 001 589 439

Unit 5, 28 Leighton Place Hornsby  
NSW 2077 AUSTRALIA

Telephone: +61 2 9476 2244  
Facsimile: +61 2 9476 2902

e-mail: [sales@aicpl.com.au](mailto:sales@aicpl.com.au)  
Internet: [www.aicpl.com.au](http://www.aicpl.com.au)

---

## Table of Contents

---



<b>Introduction</b> . . . . .	<b>3</b>
Simple time adjustment . . . . .	3
Master/Slave clock operation . . . . .	3
Alarm relay operation . . . . .	4
Alarm loop flow chart . . . . .	5
Allocating more than one alarm number to a relay . . . . .	6
Overlapping alarms . . . . .	6
<b>Mechanical installation</b> . . . . .	<b>7</b>
<b>Electrical Installation</b> . . . . .	<b>8</b>
Power supply connections. . . . .	8
38, 39, 45 and 57mm display power supplies . . . . .	8
100mm & 200mm display power supplies. . . . .	8
Mains synchronisation wiring . . . . .	10
Interconnection of displays. . . . .	10
Serial communications connections . . . . .	10
Link settings . . . . .	11
Relay connections . . . . .	11
Optional temperature sensor connections . . . . .	11
Optional remote pushbutton connector . . . . .	11
Optional GPS input. . . . .	12
<b>Explanation of Functions</b> . . . . .	<b>13</b>
<b>Function Table</b> . . . . .	<b>20</b>
<b>Specifications</b> . . . . .	<b>23</b>
Technical Specifications . . . . .	23
Options. . . . .	23
Physical characteristics . . . . .	23
<b>Serial communications</b> . . . . .	<b>25</b>
<b>Guarantee and Service</b> . . . . .	<b>28</b>

---

# 1 Introduction

---

This manual contains information for the installation and operation of the LD-RTC clock.

This instrument may be used as a 12 or 24 hour clock or may be set to display day/month/year. The  and  pushbuttons located on the main circuit board can be used to force the display to toggle between the date and time display (and temperature if this option is fitted). For example on a 6 digit display a total of seven display options are available, these are:

month.day.year  
day.month.year  
hours.min.secs  
month.day  
day.month  
days  
hours.minutes

The exact display choice will depend on the number of digits in the chosen display, see **d: SP** **FNSE** function in the "Explanation of functions" chapter.

An inbuilt light sensor allows the clock to automatically change its brightness level to suit the ambient light level. Alternatively the display brightness level can be set to a fixed value or toggled between a low and high brightness value via an external switch.

An optional temperature sensor can be added. When this option is used the display can be made to alternate between a time and temperature display.

Clock synchronisation can be set to be from either the units internal clock generator, the 50Hz mains frequency, the 60Hz mains frequency, an optional high accuracy 10MHz crystal or optional GPS satellite receiver.

Setup is accomplished by push button operation. "On screen" prompts are given for each function to assist in setting up the instrument. Some changes may require dismantling the instrument to alter PCB links.

Serial (RS232, RS485 or 20mA serial current loop) communications is optionally available.

Unless otherwise specified at the time of order, your LD-RTC has been factory set to a standard configuration, see the function table for your selected mode for default settings.

Full electrical isolation between power supply and input signals is provided by the LD-RTC, thereby eliminating grounding and common voltage problems. This isolation feature makes the LD-RTC ideal for interfacing to computers, PLC's and other data acquisition devices.

The LD-RTC series of monitors are designed for high reliability in industrial applications. The high brightness LED display provides good visibility, even in areas with high ambient light levels.

## 1.1 Simple time adjustment

For simple time adjustment use the **SEt rEt** function as described on page 11 in the "Explanation of functions" chapter. This function allows to user to set the clock to the current time. Note that entry via **CAL** mode is required (see page 11) is required to gain access to this function.

Alternative methods of time adjustment are available via the **ADJSt SECS** and **ADJSt hour** functions. The **ADJSt SECS** function allows the user to add or subtract a number of seconds and tenths of seconds from the current time. The **ADJSt hour** function allows hours to be added or subtracted. These functions may be used instead of the **SEt rEt** function if required.

## 1.2 Master/Slave clock operation

The LD-RTC can be used with other model LD-RTC, PM4-RTC (panel mount version) or RM4-RTC (DIN rail mount version) to form a master/slave clock system. The instruments used must be fitted with optional serial communications. Refer to the "Serial communications" appendix in this manual for details of LD-RTC serial commands. When used in a master/slave system the master unit must have its **Q.PUt** function set to **UPdt** and the slave units must all have their **Q.PUt** functions set to **POLL**.

### 1.3 Alarm relay operation

The LD-RTC is supplied with two alarms relays as standard . The alarm functions will not be seen and no alarm operation is possible unless the display is set to show hours.minutes or hours.minutes.seconds.

It is essential that the correct time, date and year is set for successful alarm operation. The LD-RTC uses the date and year settings to calculate the day of the week (Monday to Sunday).

The alarm operation mode in this instrument allows up to 32 separate alarms to be made, **A 1** to **A 32**. Each of these 32 alarm settings requires the choice of:

1. Choice of alarm number (**SEt AL**) - i.e. alarm **A 1** to **A 32**.
2. Alarm switch on time (**Ax ON**) - i.e. the time at which the relay energises. Note: the “x” in **Ax ON** and all the other settings below will be replaced by the number **1** to **32** when displayed, depending on the alarm number selected.
3. Alarm duration (**Ax dur**) - up to 23 hours 59 mins 59 secs. Note; longer duration's are possible by using overlapping times and more than one alarm to operate a chosen relay.
4. Days of the week on which the alarm will operate (**DAY**).
5. Choice of relay which will operate for that alarm number (**Ax FLY**)

When the operator enters the function or calibration mode and selects an alarm number at the **SEt AL** function the LD-RTC will automatically loop back to the **SEt AL** function at the end of the alarm setup sequence i.e. at the end of step 5 the display will return to step 1. This looping back allows the next alarm number choice to be made without having to pass through the other instrument functions. To exit this loop the user can either press the **P** button twice or, if the instrument has no **P** button, choose the option **End** at the **SEt AL** function and then press the **F** button. When the loop is exited the display will move on to the next function in the list outside the alarm setup loop i.e. **Ax n.o** or **Ax n.c**.

The process of setting up the alarms (alarm 3 will be used for example purposes in this explanation) is as follows (see also the flow chart illustration which follows):

**A.** Enter the **FUNC** mode or **CAL** mode (see page 11, “Explanation of functions” chapter, for method). The display should show **FUNC** followed by the first function **ADJSt SECS** (if enabled, see **FtC ADJSt** page 15).

**B.** Press and release **F** until the display shows **SEt AL** . If the **F** button is pressed at this stage it will be assumed that no alarms are to be set and the display will move to the **A In.o** or **A In.c** function. To select an alarm number press **▲** and **▼** simultaneously, the display will show **A 1** . i.e. alarm number 1. Use the **▲** or **▼** button to select the alarm number required i.e. **A 1** to **A 32**. If **End** is selected then it will be assumed that no new alarm settings are required. For this example **A 3** will be chosen.

Note: the alarm setting relates only to the alarm number and does not refer to the relay itself i.e. if **A 3** is selected at this point it simply means that alarm number 3 is the one currently being setup and does not mean that relay 3 is being selected.

**C.** Press **F**. The display will show **A 3 ON**. Use the **▲** or **▼** button to select the time of day at which the relay (which will be chosen later) is to be activated. This on time will be in 24 hour time display format even if the main display is in 12 hour time display format.

**D.** Press **F**. The display will show **A 3 dur** . Use the **▲** or **▼** button to select the required duration of the relay activation.

**E.** Press **F**. The display will show **DAY** followed by **MON** (Monday) and either **on** or **OFF** . Use the **▲** or **▼** button to select either **on** or **OFF** for Mondays, if **on** is selected it means that the current alarm (**A 3**) will operate on Mondays, if **OFF** is selected then the alarm (**A 3**) will not operate on Mondays. Press **F** to move on to the next day (**TUE**) and again select **on** or **OFF** . Continue the process up to and including Sunday.

**F.** Press **F**. If more than one relay is fitted the display will move on to the **A 3 FLY** function. Use the **▲** or **▼** button to select the required relay to be assigned to the current alarm (**A 3**). If only one relay is fitted the display will now loop back to the **SEt AL** function to allow another alarm number selection.

**Example:** Use alarm **A 1** to make relay 2 activate for 2 hour 15 minutes on every week day (not weekends) starting at 10.00 pm use the following settings.

```

SEt AL      A 1
A 1 ON      22.00
A 1 dur     2. 15
dAY MON on
TUE on
WEd on
thu on
Fri. on
SAT OFF
Sun OFF
A 1 FLY 2
  
```

The alarm settings will cause relay 2 to activate on every Monday to Friday at 10.00 pm (22.00) and reset 2 hours and 15 minutes later. For example the relay will activate at 10.00 pm on Monday and reset at 00.15 am the next day (Tuesday), 2 hours 15 minutes after activating.

#### 1.4 Alarm loop flow chart

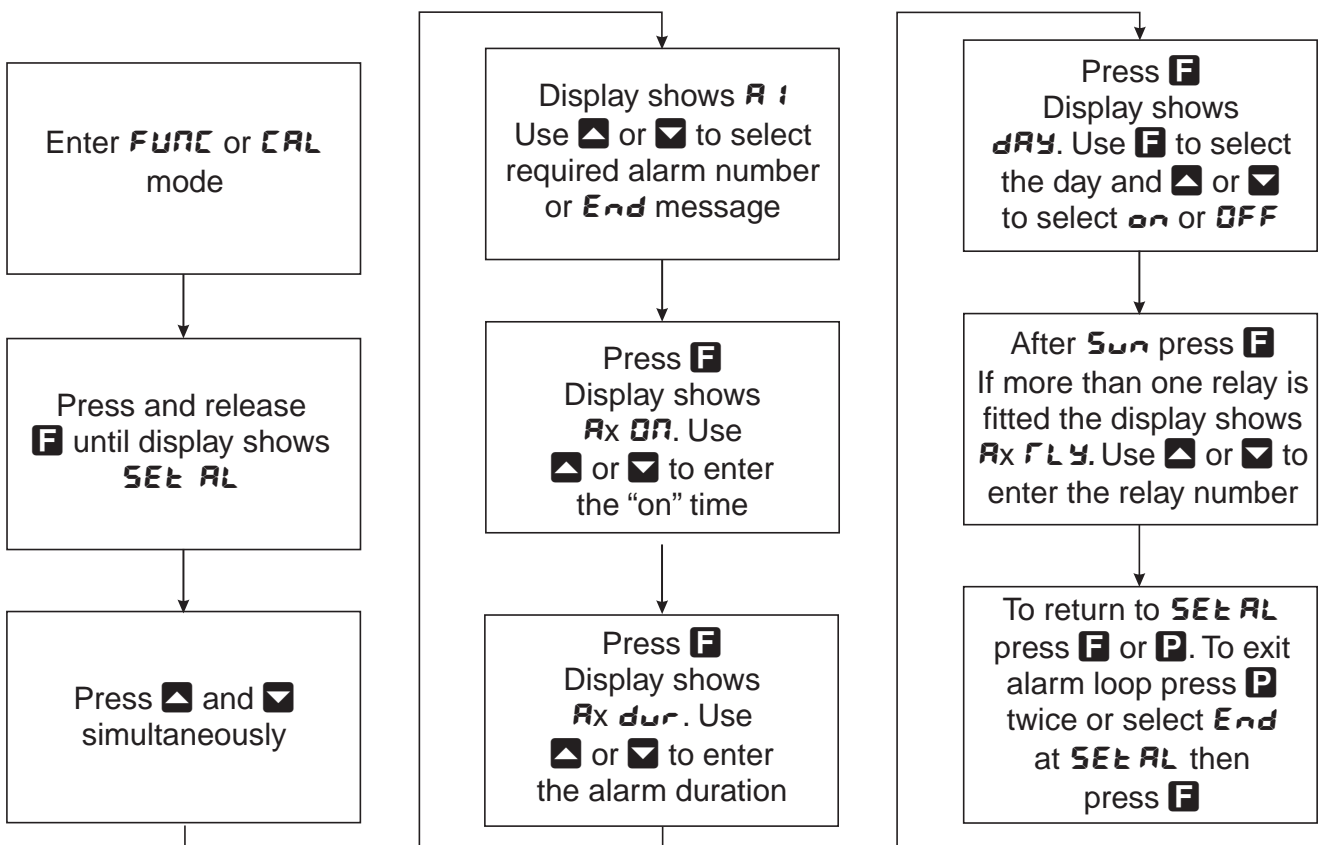

## 1.5 Allocating more than one alarm number to a relay

A relay can be allocated to any number of the 32 available settings. For example if alarm numbers **A 1**, **A2**, **A3** and **A 10** all have relay 2 selected at the **AXFLY** function then each of these alarm settings will control relay 2 operation. Each of the alarms need to be individually set up by passing through the alarm loop and making the required settings for each alarm number.

## 1.6 Overlapping alarms

A relay can be allocated to more than one alarm number with overlapping times if required. A typical application for an overlapping alarm is in cases where an alarm longer than 24 hours is required. For example alarm number **A 1** could be set to operate for 20 hours starting at a given time and alarm number **A2** could be set to operate for a further 20 hours. If the **A2** program on time occurs just before the **A 1** duration ends then the relay will not de energise until the 40 hours from the initial **A 1 ON** time is up.

## 2 Mechanical installation

### 100mm 4 digit LED or Electromagnetic

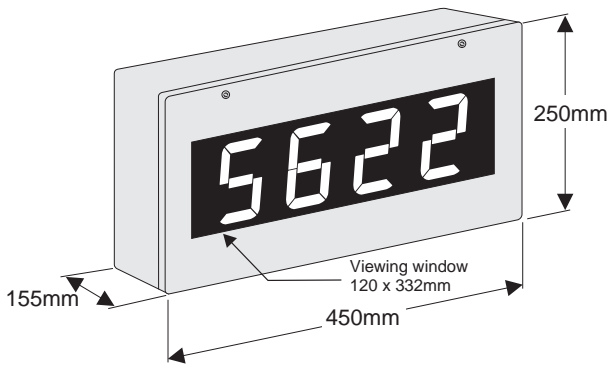

### 100mm 5 digit Electromagnetic only

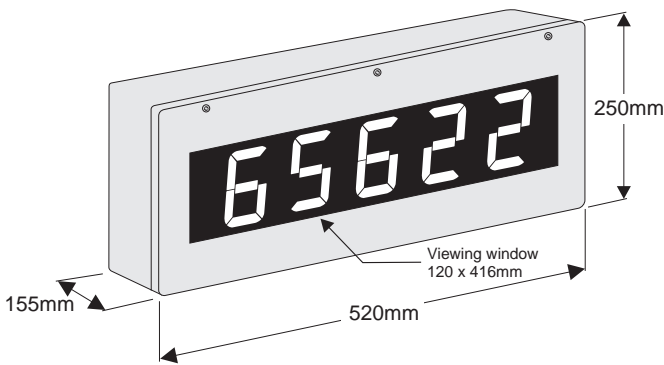

### 100mm 6 digit LED or Electromagnetic

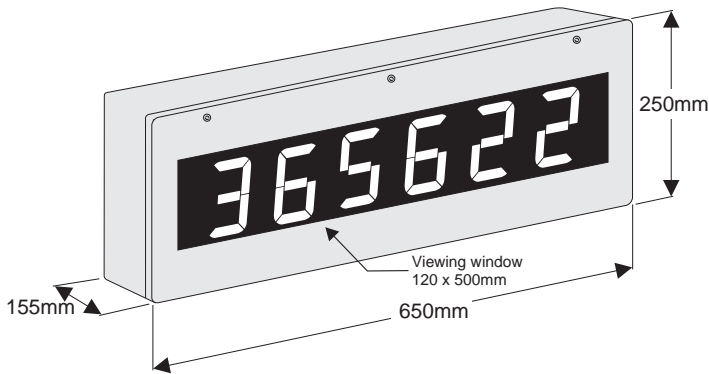

### 180mm 4 digit LED

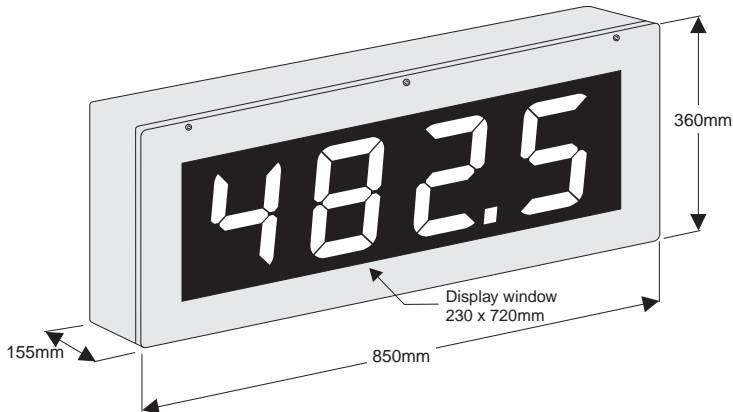

### 38mm 6 digit LED, 45mm 5 digit & 57mm 4 digit LED

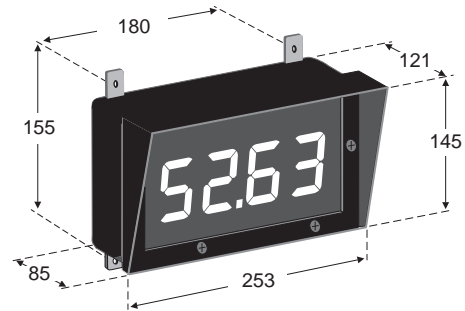

Four mounting kit brackets are supplied for use with 100 & 200mm display models. Diagrams below illustrate vertical and horizontal installation. If mounting without the brackets is preferred then the 9mm dia. case holes provided for the brackets can be used as alternative mounting holes. If the supplied brackets are not used in mounting these holes should be sealed against dust and water.

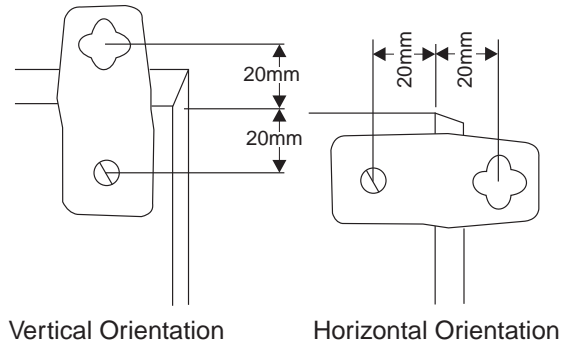

# 3 Electrical Installation

The LD-RTC instrument is designed for continuous operation and no power switch is fitted to the unit. It is recommended that an external switch and fuse be provided to allow the unit to be removed for servicing.

The terminal blocks are plug in screw type for ease of installation and allow for wires of up to 1.5mm<sup>2</sup> (2.5mm<sup>2</sup> for relay, AC or isolated DC supply connections) to be fitted. Connect the wires to the appropriate terminals as indicated below. Refer to other details provided in this manual to confirm proper selection of voltage, polarity and input type before applying power to the instrument. When power is applied the instrument will cycle through a display sequence, indicating the software version and other status information.

## MAIN CIRCUIT BOARD LAYOUT

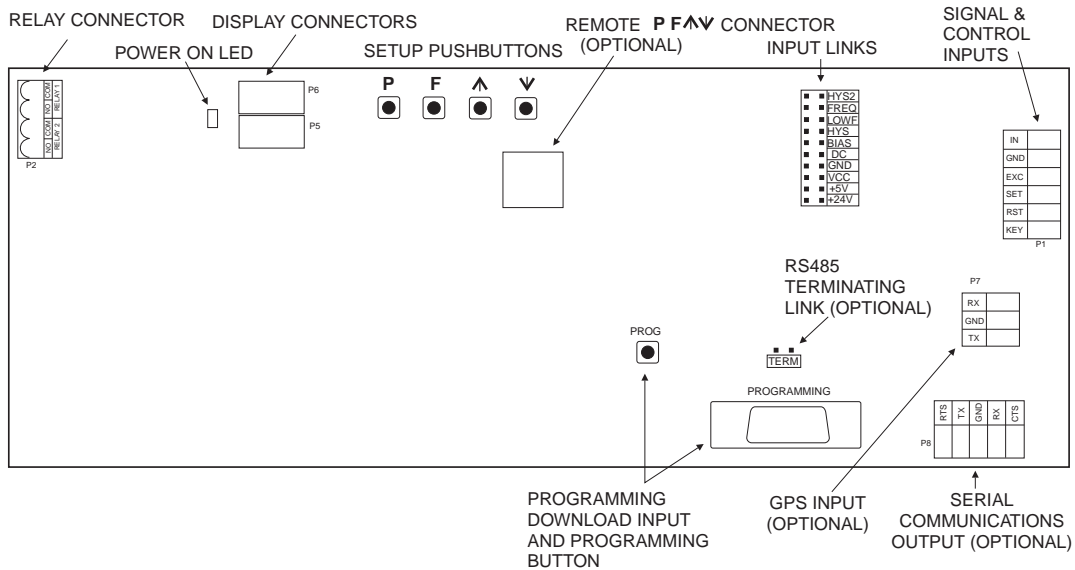

### 3.1 Power supply connections

### 3.2 38, 39, 45 and 57mm display power supplies

AC power connections use a plug in connector with screw terminals at P12 (2.5mm<sup>2</sup> max. wire diameter). Isolated DC supplies (12-48VDC) use the same terminals.

Non isolated DC supplies (24VDC only) may be connected directly to the main circuit board power supply connector via the plug in connector terminals at P11 (1.5mm<sup>2</sup> max wire diameter).

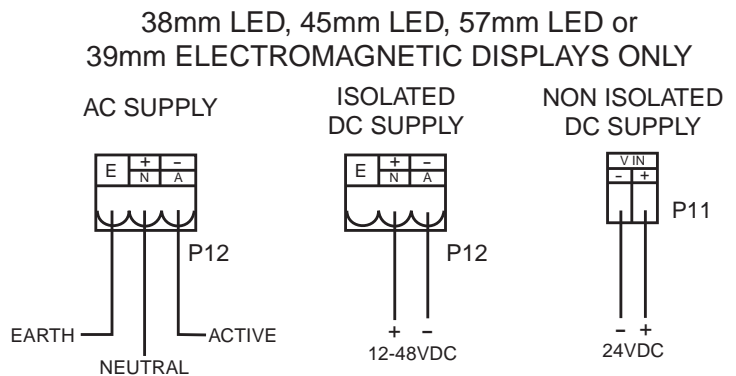

### 3.3 100mm & 200mm display power supplies

Non isolated 24VDC supplies for 100 & 200mm displays connect directly to the terminal block on the base board, red +V, black -V. Isolated DC supplies (12 to 24VDC) connect to the isolated supply pcb on the base board. AC supplies connect to the transformer primary on the base board. The base board is located under the input circuit board, see wiring diagram for AC supplies on the next page.

Power to the main circuit board comes via the ribbon cable which connects the display boards to the main circuit board via connector P4 or P5.

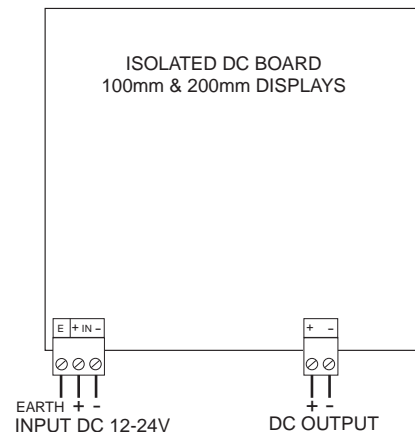

240 & 110VAC supplies.  
For 100mm/200mm LED or 100mm  
electromagnetic display types only.

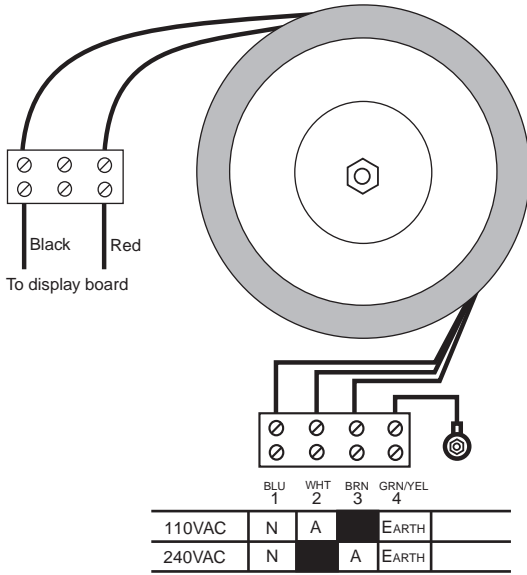

Low voltage AC supplies.  
For 100mm/200mm LED or 100mm  
electromagnetic display types only.

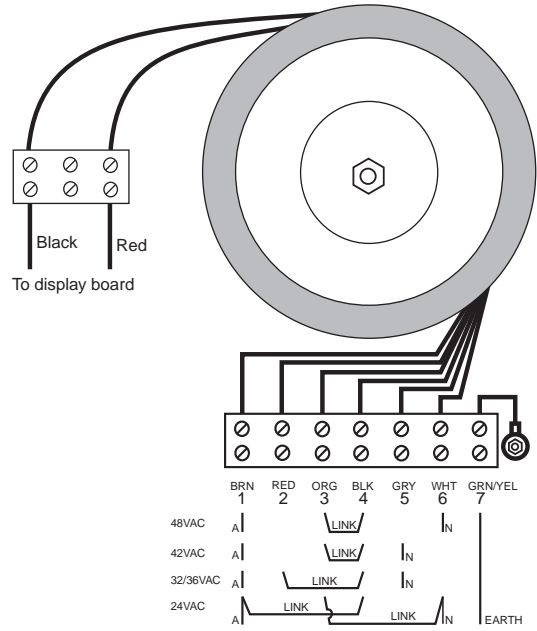

Wiring examples 240VAC & 110VAC

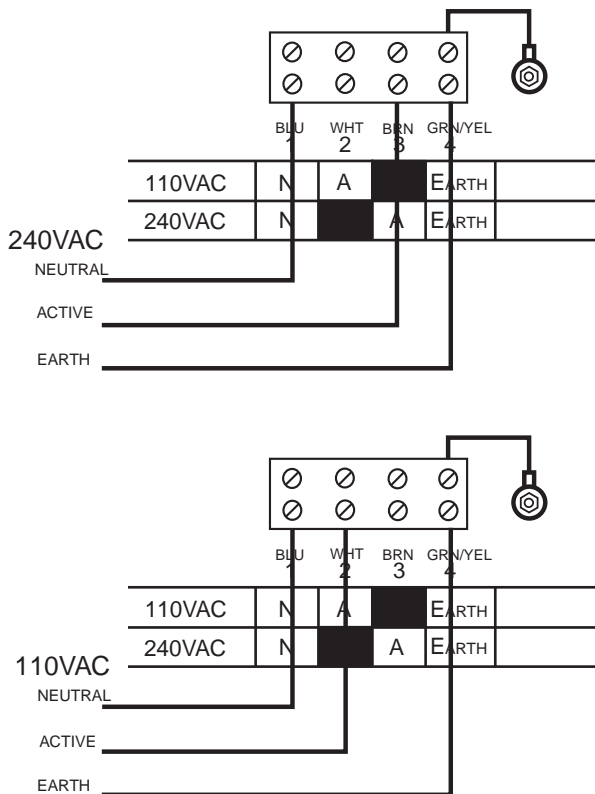

Wiring examples low voltage AC

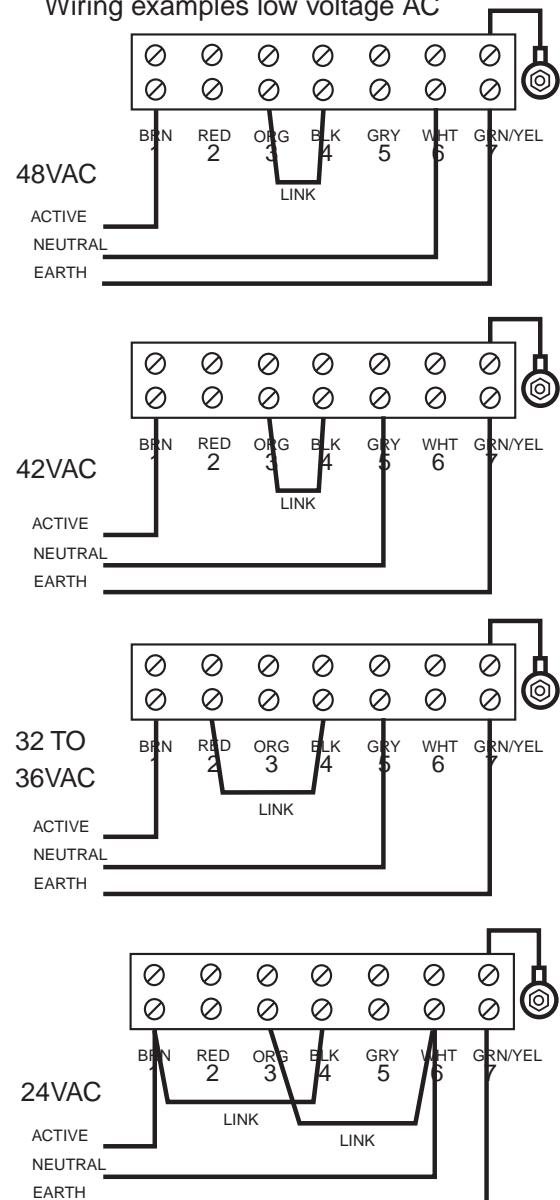

Important note: the 240V & 110V supplies use the same transformer, low voltage instruments use a different transformer. Do not use a low voltage transformer for 240V or 110V or vice versa.

### 3.4 Mains synchronisation wiring

The time can be set to synchronise from the AC supply frequency of either 50 or 60 Hz (selectable at the **rtc SYNC** function). 100mm and 200mm displays require the wiring link below. Other display types do not require this wiring link but do require that LK16 solder link at the rear of the pcb is shorted. The only input link required is LK10 (HYST2).

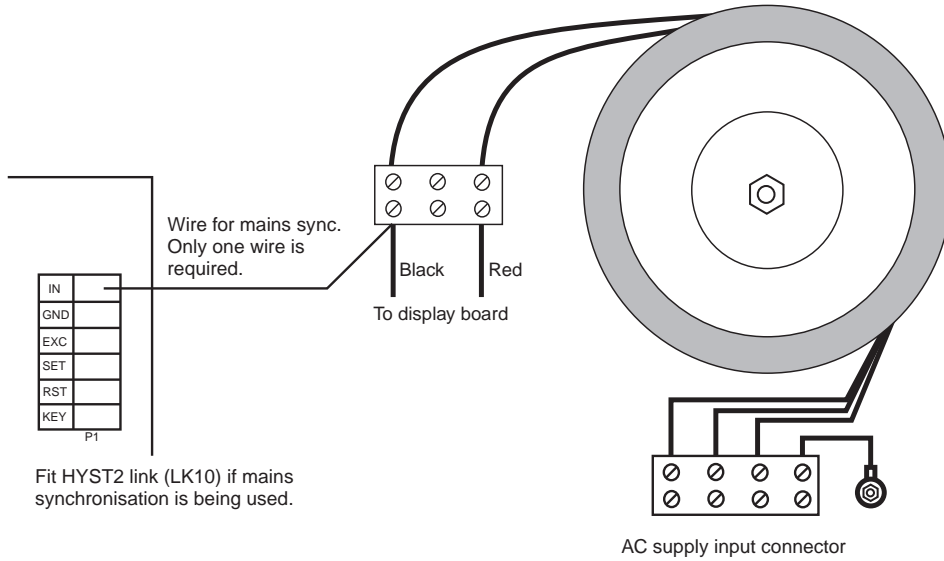

### 3.5 Interconnection of displays

The main circuit board can connect to its own display and to one other display via the P4 or P5 connectors located on the main circuit board. Alternatively serial communications can be used (see 3.7) to connect in a master/slave configuration.

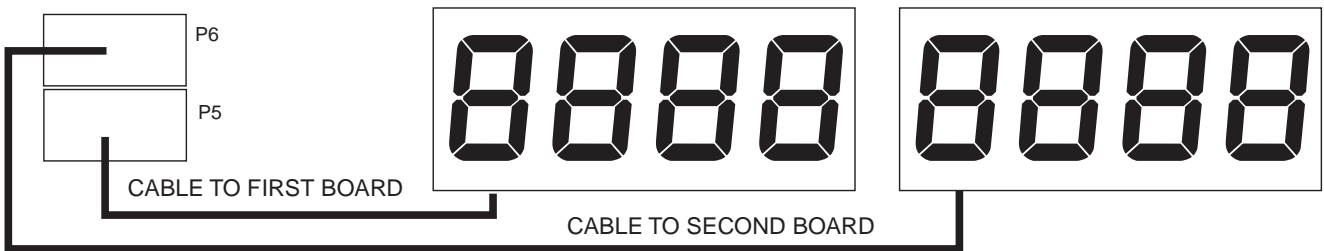

### 3.6 Serial communications connections

The diagram shows the input/output connectors for the optional serial communications. Refer to the "Serial communications" appendix for details of serial output functions.

RS232 communications use 3 core shielded cable

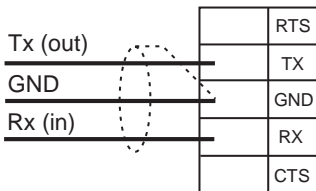

Serial communications is optional, connectors and circuitry will only be fitted if the instrument was ordered with the serial communications option. The optional serial communications will be factory configured for RS232 or RS485 communications.

Note: when connecting using RS232 the Tx line at the display connects to the Rx line at the device it is communicating with. Likewise the Rx line at the display connects to Tx. When using RS485 connections are A to A and B to B

RS485 communications use twisted pair shielded cable

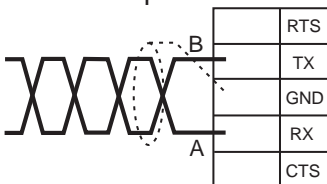

RS485 terminating link. The link should be in for long cable runs. If multiple instruments are connected insert the link if the display is the first and last unit on the line.

### 3.7 Link settings

LK10 marked HYS2 must be in for standard clock operation, links LK3 to LK9 must be out (see circuit board layout page 8 for link location). If GPS synchronisation is used then the unregulated 10-24V supply may be used via the EXC terminal. To select the unregulated 18-24V LK1 must be in (+24V).

### 3.8 Relay connections

The LD-RTC is supplied with two alarm relays as standard with connections on terminals P2. The relays are single pole, single throw types and are rated at 5A, 240VAC into a resistive load. The relay contact is voltage free and may be programmed for normally open or normally closed operation.

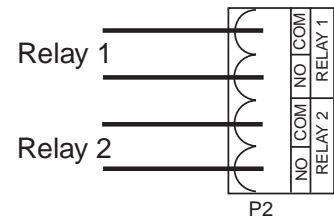

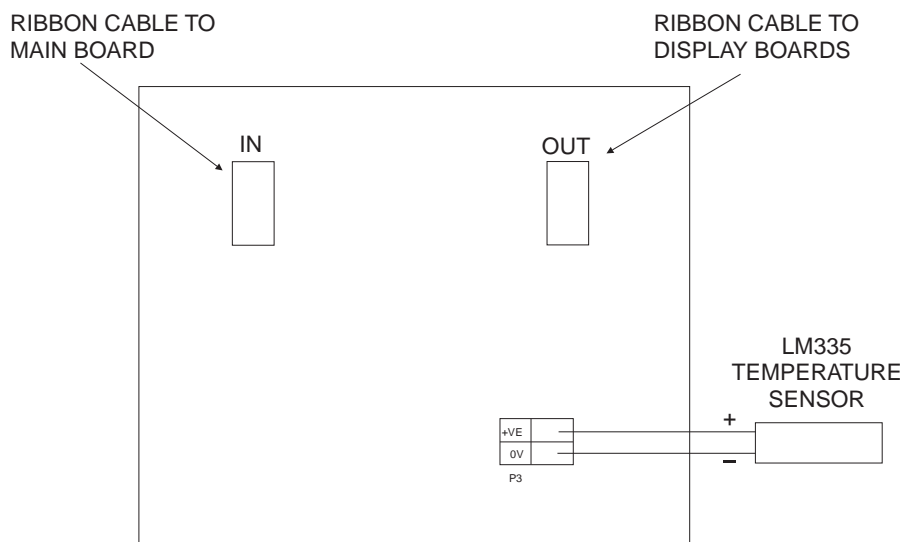

### 3.9 Optional temperature sensor connections

When the temperature sensor option is fitted a separate circuit board is used. The ribbon cable from the main board to the display boards passes through this board via the IN and OUT terminals. The temperature sensor must be LM335 type semiconductor sensor with + and - terminals wired as shown. The most common wiring colour code for this sensor is Red = + and Black = -. If the temperature sensor fails or is not fitted the temperature display will show the error message --.



### 3.10

#### Optional remote pushbutton connector

The optional remote pushbutton connector uses a 6 pin RJ45 type female connector with connections as shown. A short circuit between the **P**, **F**,  or  line to GND will cause the pushbutton to activate. If this connector is fitted a male RJ45 connector will be required to plug into the supplied socket. A special RJ45 crimping tool will be required to fit cable to the male connector and 6 way flat telephone cable should be used.

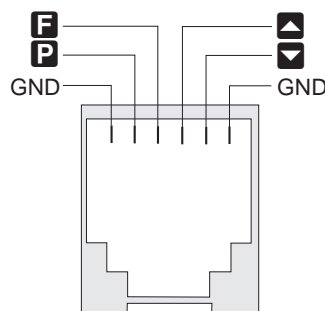

### 3.11 Optional GPS input

The optional GPS unit connects as shown. If the unregulated 18V to 24V is to be used to supply to the GPS unit then LK1 (+24V) must be in on the main circuit board. If the 5V supply is to be used to power the GPS then LK2 (+5V) must be in on the main circuit board. Only one voltage link should be in at any one time. These supplies can provide up to 50mA, check current consumption requirements of the GPS unit before using this voltage.

The serial communications setting required for most common GPS units are as follows:

```
bAud = 4800  
Prty = NONE  
Q.Psk = NONE  
Addr = 1  
SEF1 TYPE = F232  
SEF2 TYPE = NONE
```

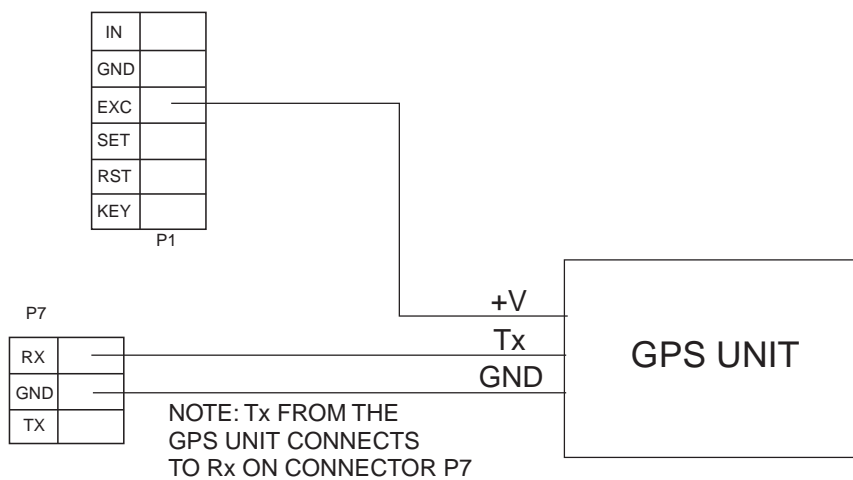

## 4 Explanation of Functions

The LD-RTC setup and calibration functions are configured through a push button sequence. Two levels of access are provided for setting up and calibrating:-

**FUNC** mode (simple push button sequence) allows access to commonly set up functions such as alarm setpoints.

**CAL** mode (power up sequence plus push button sequence) allows access to all functions including calibration parameters.

The three push buttons, located on the main circuit board, are used to alter settings. Once **CAL** or **FUNC** mode has been entered you can step through the functions, by pressing and releasing the **F** push button, until the required function is reached. Changes to functions are made by pressing the **▲** or **▼** push button (in some cases both simultaneously) when the required function is reached.

### Entering **CAL** Mode



1. Remove power from the instrument and wait 5 seconds. Hold in the **F** button and reapply power. The display will indicate **CAL** as part of the "wake up messages" when the **CAL** message is seen you can release the button. Move to step 2 below.



2. When the "wake up" messages have finished and the display has settled down to its normal reading press, then release the **F** button. Move to step 3 below.

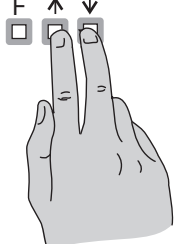

3. Within 2 seconds of releasing the **F** button press, then release the **▲** and **▼** buttons together. The display will now indicate **FUNC** followed by the first function.

Notes: If step 1 above has been completed then the instrument will remain in this **CAL** mode state until power is removed. i.e. there is no need to repeat step 1 when accessing function unless power has been removed.

The instrument should show all 8's on power up e.g. **8.8.8.8**. If the instrument does not reset then these numbers will not be seen. Switch off the instrument and allow a longer time delay before powering up again.

### Entering **FUNC** Mode

No special power up procedure is required to enter **FUNC** mode.



1. When the "wake up" messages have finished and the display has settled down to its normal reading press, then release the **F** button. Move to step 2 below.

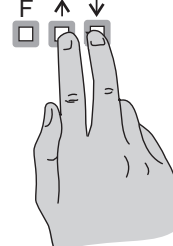









2. Within 2 seconds of releasing the **F** button press, then release the **▲** and **▼** buttons together. The display will now indicate **FUNC** followed by the first function.

### Alternative **CAL** Mode Entry

This alternative method allows **CAL** mode entry without the need to remove power:









1. Enter **FUNC** mode using the 2 steps above
2. When the first function appears press and hold the **F** button until you see the message **FUNC** followed by **CAL** (the **F** button will have to be held pressed for approximately 2 seconds)
3. You should now return to the function you were in but have full access to **CAL** mode functions













Note: when you exit back to live reading the display will remain in **CAL** mode for approximately 4 minutes, after this time you will need to repeat this process to enter **CAL** mode.

Function	Description
<b>ADJSt SECS</b>	Adjust seconds (-99.9 to 99.9) - This function allows simple adjustment in seconds of the time. The range of control is from -99.9 seconds to 99.9 seconds. e.g. if the clock is known to be 5 seconds fast then at the <b>ADJSt SECS</b> function use the  button to select -5, then press the  button to accept the change. When the display returns to its normal mode 5 seconds will have been subtracted from the time. See also <b>rtc ADJ</b> function.
<b>ADJSt hour</b>	Adjust hour - This function allows simple adjustment in hours of the time. The range of control is from -9 hours to 9 hours. e.g. if the clock is known to be 1 hour slow then at the <b>ADJSt hour</b> function use the  button to select 1, then press the  button to accept the change. When the display returns to its normal mode 1 hour will have been added to the time. See also <b>rtc ADJ</b> function. Note that the instrument will not allow the adjustment to occur if it would take the time beyond midnight this is to ensure that the date settings are not affected.
<b>SEt AL</b>	Set alarm number ( <b>A 1</b> to <b>A32</b> and <b>End</b> ) - The set alarm function allows the user to select the alarm number for which the alarm settings which follow will apply. To view and select an alarm number the  and  buttons must first be pressed simultaneously, the  or  button may then be used to select an alarm number. The choices available are <b>A 1</b> to <b>A32</b> i.e. alarm number 1 to alarm number 32. The alarm numbers refer to the alarm only and not to a relay number. e.g. if <b>A3</b> is chosen then the on time, duration, day etc. alarm functions which follow will be for alarm setting 3. This function also allows the option to select <b>End</b> . The <b>End</b> option allows exit from the alarm setup loop (see "Introduction" chapter). <b>Note:</b> the alarm functions will only be seen if the <b>di SP RANGE</b> function is set to hours, minutes etc. It will not be seen if the function is set to display days, months etc. Some of the alarm operation functions below are marked "x" in place of the relay number. The "x" indicates the relay number, the display will show the actual relay number e.g. <b>A 1n.o</b> etc.
<b>A 1 ON</b>	Alarm relay 1 on time ( <b>0.00</b> to <b>23.59</b> hours & minutes) - Displays and sets the time at which relay 1 will activate. When the alarm on time is reached the relay will activate and will remain activated for the length of time set at the <b>A 1 dur</b> function if the alarm is set to operate on that day.
<b>A2 ON</b>	Alarm relay 2 on time ( <b>0.00</b> to <b>23.59</b> hours & minutes) - Displays and sets the time at which relay 2 will activate. See <b>A 1 ON</b> above for further description.
<b>A 1 dur</b>	Alarm relay 1 duration ( <b>0.00</b> to <b>23.59</b> hours & minutes) - The alarm duration is the period of time for which the relay will remain energised once activated. At the end of the alarm duration the relay will become de-energised unless this relay has an overlapping alarm setting i.e. more than one alarm setting is being used to control the relay. Alarm duration is set in the same units as the display range setting. e.g. if the display is in hours & minutes the duration setting is in hours & minutes.
<b>A2 dur</b>	Alarm relay 2 duration ( <b>0.00</b> to <b>23.59</b> hours & minutes) - The alarm duration is the period of time for which the relay will remain energised once activated. See <b>A 1 dur</b> for further description.
<b>dAY</b>	Day setting - The day setting allows each day of the week to be selected as on or off. This means that a given alarm setting can be programmed to operate at any given day or days of the week. The options are: Monday <b>MON on</b> or <b>OFF</b> Tuesday <b>TUE on</b> or <b>OFF</b> Wednesday <b>WEd on</b> or <b>OFF</b> Thursday <b>Thu on</b> or <b>OFF</b> Friday <b>Fr, on</b> or <b>OFF</b> Saturday <b>SAt on</b> or <b>OFF</b> Sunday <b>Sun on</b> or <b>OFF</b>

<b>Function</b>	<b>Description</b>
<b>Ax FLY</b>	Choose relay for alarm number ( <b>1</b> or <b>2</b> ) - The functions allows a choice of relay to be used for the alarm number currently selected. Choices are <b>1</b> or <b>2</b> .e. relay 1 or 2. For example if alarm number <b>A 12</b> has been selected via the <b>SEt AL</b> function then choosing <b>2</b> at the <b>A 12 FLY</b> function will mean that relay 2 will operate at the on time selected by the <b>A 12 ON</b> function and will remain on for the duration selected via the <b>A 12 dur</b> function.
<b>A 1n.o</b> or <b>A 1n.c</b>	Alarm relay 1 normally open or normally closed - Displays and sets the alarm relay 1 action to normally open (de-energised) or normally closed (energised), when no alarm condition is present. A normally closed alarm is often used to provide a power failure alarm indication.
<b>A2n.o</b> or <b>A2n.c</b>	Alarm relay 2 normally open or normally closed - Displays and sets the alarm relay 2 action. See <b>A 1n.o</b> or <b>A 1n.c</b> above for a further description.
<b>br 9t</b>	Manual display brightness - not seen if <b>br 9t AUTO</b> is set to <b>on</b> . Displays and sets the digital manually set display brightness. The display brightness is selectable from <b>1</b> to <b>63</b> , where <b>1</b> = lowest intensity and <b>63</b> = highest intensity. This function is useful for reducing glare in low light environments.
<b>br 9t AUTO</b>	Automatic display brightness adjustment ( <b>on</b> or <b>OFF</b> ). Not applicable unless the optional light sensor is fitted. The automatic brightness adjustment uses the optional light sensor to gauge the required brightness level for the environment. The high and low brightness limits are set at the <b>br 9t HI 9H</b> and <b>br 9t Lo</b> functions described below. If the optional light sensor is not fitted.
<b>br 9t HI 9H</b>	Automatic brightness high level ( <b>10</b> to <b>63</b> ) - seen only when <b>br 9t AUTO</b> is set to <b>on</b> . The high brightness level sets the maximum brightness which the automatic brightness control can achieve with <b>63</b> being the highest intensity.
<b>br 9t Lo</b>	Automatic brightness low level ( <b>1</b> to <b>63</b> ) - seen only when <b>br 9t AUTO</b> is set to <b>on</b> . The low brightness level sets the minimum brightness which the automatic brightness control can achieve with <b>63</b> being the highest intensity.
<b>duLL</b>	Remote display brightness - seen only if <b>r.i NP</b> function is set to <b>duLL</b> and <b>br 9t AUTO</b> is set to <b>OFF</b> . Displays and sets the level for remote input brightness switching, see <b>r.i NP</b> function. When the remote input is set to <b>duLL</b> the remote input (terminal labeled "KEY") can be used to switch between the display brightness level set by the <b>br 9t</b> function and the display brightness set by the <b>duLL</b> function. The display brightness is selectable from <b>0</b> to <b>63</b> , where <b>0</b> = lowest intensity and <b>63</b> = highest intensity. This function is useful in reducing glare when the display needs to be viewed in both light and dark ambient light levels.

Function	Description
<b>FI NP</b>	<p>Remote input function - Terminals marked “KEY ” and “GND” are the remote input terminals. When these terminals are short circuited, via a pushbutton or keyswitch the instrument will perform the selected remote input function. A message will flash to indicate which function has been selected when the remote input pins are short circuited. The remote input functions are as follows:</p> <p><b>NONE</b> - no remote function required</p> <p><b>P.HLD</b> - peak hold. Not applicable to LD-RTC</p> <p><b>d.HLD</b> - display hold. Not applicable to LD-RTC</p> <p><b>H<sub>p</sub></b> - peak memory. Not applicable to LD-RTC</p> <p><b>Lo</b> - valley memory. Not applicable to LD-RTC</p> <p><b>H<sub>p</sub>, Lo</b> - toggle between <b>H<sub>p</sub></b> and <b>Lo</b> displays. Not applicable to LD-RTC</p> <p><b>SP.AC</b> - setpoint access only. This blocks access to any functions except the alarm setpoint functions unless the remote input pins are short circuited or entry is made via <b>CAL</b> mode</p> <p><b>No.Ac</b> - no access. This blocks access to all functions unless the remote input pins are short circuited or entry is made via <b>CAL</b> mode</p> <p><b>d/ SP</b> - display toggle. Not applicable to LD-RTC</p> <p><b>dULL</b> - display brightness control. The remote input can be used to change the display brightness. When this mode is selected the display brightness can be switched, via the remote input, between the brightness level set at the <b>brgt</b> function and the brightness level set at the <b>dULL</b> function</p>
<b>ACCESS</b>	<p>Access mode (<b>OFF</b>, <b>EASY</b>, <b>NONE</b> or <b>ALL</b>) - The access mode function <b>ACCESS</b> has four possible settings. If set to <b>OFF</b> the mode function has no effect or alarm relay operation. The <b>EASY</b> option is not applicable to this instrument,. If set to <b>NONE</b> there will be no access to any functions via <b>FUNC</b> mode, entry via <b>CAL</b> mode must be made to gain access to alarm functions. If set to <b>ALL</b> then all functions will be accessible via <b>FUNC</b> mode i.e. there is no need to enter <b>CAL</b> mode. This function provides an alternative to using the <b>FI NP</b> function for easy access or no access mode thereby allowing the remote input to be programmed for an alternative use.</p>
<b>rtc</b>	<p>Real time clock display mode ( <b>12hr</b> or <b>24hr</b> ) - The real time clock may be set to 12 hour display mode, indicated by <b>12hr</b> on the display or 24 hour display mode, indicated by <b>24hr</b> on the display. Use the <input type="checkbox"/> or <input type="checkbox"/> button to alter the mode if required.</p>
<b>rtc SYNC</b>	<p>Real time clock synchronisation - Displays and sets the clock synchronisation to be used.</p> <p>Select <b>NONE</b> for internal clock chip use.</p> <p>Select <b>50H</b> to synchronise the clock to 50Hz mains frequency.</p> <p>Select <b>60H</b> to synchronise the clock to 60Hz mains frequency.</p> <p>Select <b>CRYST</b> to synchronise to the optional 10MHz high accuracy clock crystal if this option is fitted.</p> <p>Select <b>GPS</b> for global positioning satellite synchronisation if the GPS option is fitted</p>
<b>UTC OFFSE</b>	<p>Universal time offset for GPS synchronisation ( - <b>720</b> to <b>720</b> minutes) - sets the offset in minutes from universal time. When using optional GPS synchronisation the signal transmitted uses a “universal time”. The offset function allows the local offset from this “universal” time to be input in minutes. For example if local time is 10 hours (600 mins.) ahead of GPS universal time then set <b>UTC OFFSE</b> to <b>600</b>.</p>
<b>dSt AJSt</b>	<p>Daylight saving time automatic adjustment (<b>on</b> or <b>OFF</b>) - If automatic daylight saving time adjustment is not required set this function to <b>OFF</b>. If automatic daylight saving time adjustment is required set this function to <b>on</b>. If set to <b>on</b> then the four <b>dSt</b> functions below will appear and will need to be set.</p>

Function	Description
<b>dSt ON</b>	Daylight saving Sunday start ( <b>LAST . 1St . 2nd . 3rd or 4th</b> ). Select 1st, 2nd, 3rd or 4th Sunday in the month to start daylight saving time adjustment. The hour will change at 0200 on the Sunday morning selected. This function will only be seen if <b>dSt ADJSt</b> is set to <b>on</b> .
<b>dSt ON</b>	Daylight saving month start ( <b>JAN . FEB . MAR . APR . MAY . JUN . JULY . AUG . SEP . OCT . NOV or DEC</b> ). Allows selection of the month to start daylight saving time adjustment. This function will only be seen if <b>dSt ADJSt</b> is set to <b>on</b> .
<b>dSt OFF</b>	Daylight saving Sunday finish ( <b>LAST . 1St . 2nd . 3rd or 4th</b> ). Select 1st, 2nd, 3rd or 4th Sunday in the month to end daylight saving time adjustment. The hour will change at 0200 on the Sunday morning selected. This function will only be seen if <b>dSt ADJSt</b> is set to <b>on</b> .
<b>dSt OFF</b>	Daylight saving month end ( <b>JAN . FEB . MAR . APR . MAY . JUN . JULY . AUG . SEP . OCT . NOV or DEC</b> ). Allows selection of the month to end daylight saving time adjustment. This function will only be seen if <b>dSt ADJSt</b> is set to <b>on</b> .
<b>COLN</b>	Colon ( <b>0, 1 or 2</b> ) - Sets the operation of the display colon, note that colons may not always be fitted. If set to 0 the colon flashing will be the decimal point on the relevant display digit. If set to 1 the center colons (if fitted will flash). Setting 2 is required on old style 178mm digit displays using pcb type LED178F displays fitted with center colons.
<b>SEt rtc</b>	Set real time clock - Sets the current time for real time clock mode of operation. To alter the current time setting press, then release the  and  buttons simultaneously when the <b>SEt rtc</b> function is displayed. The display will show the time setting. Use the  or  button to alter the time as required.
<b>SEt dAtE</b>	Real time clock, set the date - Sets the current date for real time clock mode of operation. Use the  or  button to alter the date as required. The days will alter first followed by the month.
<b>SEt YEAr</b>	Real time clock, set the year - Sets the current year for real time clock mode of operation. Use the  or  button to alter the year as required.
<b>di SP rAnGE</b>	Display range - The display range function allows selection of various display modes. For example on a 6 digit display a total of seven display options are available, these are: <b>ñ.d.Y.</b> to display month.day.year <b>d.ñ.Y.</b> to display day.month.year <b>h.ñ.S.</b> to display hours.minutes.seconds <b>ññ.dd</b> to display month.day <b>dd.ññ</b> to display day.month <b>ddd</b> to display days <b>HH.ññ</b> to display hours.minutes The <b>ñ.d.Y.</b> , <b>d.ñ.Y.</b> and <b>h.ñ.S.</b> options are applicable to 6 digit displays only.
<b>rtc ADJSt</b>	Time adjustment access ( <b>on or OFF</b> ) - The functions <b>ADJSt SECS</b> and <b>ADJSt hour</b> are placed at the beginning of the function table to give easy access for basic adjustment. When set to <b>on</b> the operator may gain access to the first two functions simply by entering via <b>FUNC</b> mode (see the first page of this chapter). When set to <b>OFF</b> the operator must enter via <b>CAL</b> mode to gain access to these functions.
<b>°C</b>	Temperature display on or off. Select <b>on</b> if a temperature sensor is fitted and you wish to display both time and temperature. Select <b>OFF</b> if no temperature sensor is fitted or if you do not wish to display both time and temperature. If set to <b>OFF</b> none of the remaining temperature related functions will be seen.
<b>°C SECS</b>	Number of seconds for temperature reading to appear on display before time is displayed ( <b>0 to 60</b> seconds). Leave this set to 0 if the optional temperature sensor is not fitted.
<b>rtc SECS</b>	Number of seconds for time reading to appear on display before temperature is displayed ( <b>0 to 60</b> seconds). This function will not be seen if <b>°C SECS</b> is set to <b>0</b> .

Function	Description
°C CAL 1	<p>Temperature calibration first point. To perform a temperature calibration the optional temperature sensor circuit board must be fitted together with an LM335 type temperature sensor. The temperature display range is 0-50°C.</p> <p>The procedure for performing the temperature sensor first calibration point is:</p> <ol style="list-style-type: none"> <li>1. Place the temperature sensor in a known low temperature environment e.g. an ice slurry will give a temperature of 0°C.</li> <li>2. Allow the temperature reading time to stabilise.</li> <li>3. At the °C CAL 1 function press  and  simultaneously. The display will give a live temperature reading which should be stable.</li> <li>4. Press , the display will show the message °C SCL 1 followed by a value. If necessary use the  or  button to change this value to the known temperature at the probe.</li> <li>5. Press  to accept the change. The instrument will now step to the next function. If any error occurs during the process a CAL Err message will be displayed. If this message is seen check all connections to the temperature sensor and try calibration again.</li> <li>6. Now perform the second calibration, see below.</li> </ol>
°C CAL 2	<p>Temperature calibration second point.</p> <p>The procedure for performing the temperature sensor second calibration point is:</p> <ol style="list-style-type: none"> <li>1. Place the temperature sensor in a known low temperature environment of 50°C or less e.g. a warm water bath at 40°C. You will need a reference thermometer to check the temperature.</li> <li>2. Allow the temperature reading time to stabilise.</li> <li>3. At the °C CAL 2 function press  and  simultaneously. The display will give a live temperature reading which should be stable.</li> <li>4. Press , the display will show the message °C SCL 2 followed by a value. If necessary use the  or  button to change this value to the known temperature at the probe.</li> <li>5. Press  to accept the change. The instrument will now step to the next function. If any error occurs during the process a CAL Err message will be displayed. If this message is seen check all connections to the temperature sensor and try calibration again.</li> </ol>
bAud RATE	<p>Set baud rate ( 300 . 600 . 1200 . 2400 . 4800 . 9600 . 19.2 or 38.4.) - See "RS232/RS485 Commands" and "RS232/RS485 Output Option" appendix for further details.</p>
Prty	<p>Set parity (NONE, EVEN or odd) - See "RS232/RS485 Commands" and "RS232/RS485 Output Option" appendix for further details.</p>
OPUt	<p>Set RS232/485 interface mode (d, SP, Cont or POLL) - Allows user to select the RS232/485 interface operation as follows:-</p> <p><b>NONE</b> - No output required - use this setting if a GPS is connected.</p> <p><b>d, SP</b> Sends image data from the display without conversion to ASCII.</p> <p><b>Cont</b> Sends ASCII form of display data every time display is updated.</p> <p><b>POLL</b> Controlled by computer or PLC as host. Host sends command via RS232/485 and instrument responds as required.</p> <p><b>UPdt</b> This mode is used when the LD-RTC is used as a master clock in a master/slave clock system. The master clock will automatically update any other slave clocks attached to it via serial communications. All slave displays must be set to operate in <b>POLL</b> mode.</p> <p>See "RS232/RS485 Commands" and "RS232/RS485 Output Option" appendix for further details.</p>

Function	Description
<b>Addr</b>	Set unit address for polled ( <b>POLL</b> ) mode ( <b>0</b> to <b>31</b> ) - Allows several units to operate on the same RS485 interface reporting on different areas etc. The host computer or PLC may poll each unit in turn supplying the appropriate address. The unit address ranges from 0 to 31 (DEC) but is offset by 32 (DEC) to avoid clashing with ASCII special function characters (such as <STX> and <CR>). Therefore 32 (DEC) or 20 (HEX) is address 0, 42 (DEC) or 2A (HEX) addresses unit 10. See "RS232/RS485 Commands" and "RS232/RS485 Output Option" appendix for further details.
<b>SEF. 1 TYPE</b>	Select serial output option type, allows selection of no serial communications ( <b>NONE</b> ) RS232 ( <b>R232</b> ), RS485 ( <b>R485</b> ) or serial current loop ( <b>I 20</b> ). Note serial communications type is factory fitted. Changing the communication type requires hardware changes.
<b>SEF. 2 TYPE</b>	Not applicable to this instrument

### Returning to the normal measure mode

When the calibration procedure has been completed it is advisable to return the instrument to the normal mode (where calibration functions cannot be tampered with). To return to the normal mode, turn off power to the instrument, wait a few seconds and then restore power.

## 5 Function Table

Initial display	Meaning of display	Next display	Default Settings	Record Your Settings
<b>ADJSt SECS</b>	Adjust seconds	<b>-99.9 to 99.9</b>	n/a	
<b>ADJSt hour</b>	Adjust hour	<b>-9 to 9</b>	n/a	
<b>SEt AL</b>	Set alarms	<b>A 1 to A32 plus End</b>	n/a	
<b>A 1 ON</b>	Alarm 1 on time	<b>0.00 to 23.59</b>	<b>0.00</b>	See following table
<b>A 1 dur</b>	Alarm 1 duration	<b>0.00 to 23.59</b>	<b>0.00</b>	See following table
<b>A 2 ON</b>	Alarm 2 on time	<b>0.00 to 23.59</b>	<b>0.00</b>	See following table
<b>A 2 dur</b>	Alarm 2 duration	<b>0.00 to 23.59</b>	<b>0.00</b>	See following table
<b>dAY</b>	Select alarm days	<b>MON on or OFF TUE on or OFF Wed on or OFF Thu on or OFF Fri, on or OFF SAt on or OFF Sun on or OFF</b>	All set to <b>OFF</b>	See following table
<b>AxFLY</b>	Select relay to be used	<b>1 or 2</b>	<b>1</b>	See following table
<b>A 1n.o/n.c</b>	Alarm 1 normally open or normally closed	<b>A 1n.o or A 1n.c</b>	<b>A 1n.o</b>	See following table
<b>A 2n.o/n.c</b>	Alarm 2 normally open or normally closed	<b>A 2n.o or A 1n.c</b>	<b>A 2n.o</b>	See following table
<b>br 9t</b>	Manual brightness level	<b>1 to 63</b>	<b>63</b>	
Function below are accessible only via <b>CRAL</b> mode				
<b>br 9t AUtO</b>	Automatic brightness control on or off	<b>on or OFF</b>	<b>on</b>	
<b>br 9t Hi 9H</b>	Automatic high brightness level	<b>1 to 63</b>	<b>63</b>	
<b>br 9t Lo</b>	Automatic low brightness level	<b>1 to 63</b>	<b>10</b>	
<b>dULL</b>	Remote input brightness control	<b>0 to 15</b>	<b>0</b>	
<b>r. I NP</b>	Remote input	<b>NONE . P.HLd . d.HLd . Hi . Lo . Hi . Lo . SP.AC . No.AC . di SP or dULL</b>	<b>NONE</b>	
<b>ACCS</b>	Access mode	<b>OFF . EASY . NONE or ALL</b>	<b>OFF</b>	
<b>r tc</b>	Display mode	<b>12hr or 24hr</b>	<b>24hr</b>	
<b>r tc SYNC</b>	Clock sync.	<b>NONE . 50K 60K . CF45 or 9PS</b>	<b>NONE</b>	
<b>Utc OFFSt</b>	Time offset (minutes) from GPS time	<b>-720 to 720</b>	<b>600</b>	
<b>dSt ADJSt</b>	Automatic daylight saving on or off	<b>on or OFF</b>	<b>on</b>	
<b>dSt ON</b>	Sunday on which daylight saving starts	<b>LAST, 1St, 2nd, 3rd or 4th</b>	<b>LAST</b>	
<b>dSt ON</b>	Month in which daylight saving starts	<b>JAN . FEB . MAR . APR . MAY . JUN . JULY . AUG . SEP . Oct . Nov . DEC</b>	<b>Oct</b>	
<b>dSt OFF</b>	Sunday on which daylight saving ends	<b>LAST, 1St, 2nd, 3rd or 4th</b>	<b>LAST</b>	

<b>dSt OFF</b>	Month in which daylight saving ends	<b>JAN.FEB.MAR.APR. MAY.JUN.JULY.AUG. SEP.Oct.NOV.DEC</b>	<b>MAR</b>	
<b>COLN</b>	Colon operation	<b>0, 1 or 2</b>	<b>0</b>	
<b>SEt rtc</b>	Set clock	Time setting	n/a	
<b>SEt dAtE</b>	Set date	Value in memory	n/a	
<b>SEt YEAr</b>	Set year	Value in memory	n/a	
<b>dI SP rNGE</b>	Set display mode	<b>nn.dd dd.nn ddd HH.nn (also n.d.y.d.n.y or H.n.S for 6 digit displays)</b>	<b>HH.nn or H.n.S</b>	
<b>rtc ADJSt</b>	Time adjustment access	<b>on or OFF</b>	<b>on</b>	
<b>°C</b>	Temperature display	<b>on or OFF</b>	<b>OFF</b>	
<b>°C SECS</b>	Number of seconds for temperature display	<b>0 to 60</b>	<b>3</b>	
<b>rtc SECS</b>	Number of seconds for time display	<b>0 to 60</b>	<b>5</b>	
<b>°C CAL 1</b>	Temperature calibration first point	n/a	n/a	
<b>°C CAL 2</b>	Temperature calibration second point	n/a	n/a	
<b>bAud rAtE</b>	Baud Rate Select	<b>300.600.1200.2400. 4800.9600.19.2 or 38.4</b>	<b>9600</b>	
<b>Prty</b>	Parity Select	<b>none.EVEN or odd</b>	<b>none</b>	
<b>Q.PUt</b>	Serial communications mode	<b>UPdt.POLL.Cont or dI SP</b>	<b>UPdt</b>	
<b>Addr</b>	Address	<b>0 to 31</b>	<b>0</b>	
<b>SEr1 tYPE</b>	Serial Input 1 Type	<b>none.r232.r485. or 120</b>	<b>none</b>	
<b>SEr2 tYPE</b>	Serial Input 2 Type	<b>none.r232 or r485.</b>	<b>none</b>	

Function shaded are accessible only if the option is fitted

**Alarm settings - record your settings here**

Alarm no.	A 1 ON	A 1 dur	A 2 ON	A 2 dur	DAY						
					Mon	Tue	Wed	Thu	Fri	Sat	Sun
A 1											
A 2											
A 3											
A 4											
A 5											
A 6											
A 7											
A 8											
A 9											
A 10											
A 11											
A 12											
A 13											
A 14											
A 15											
A 16											
A 17											
A 18											
A 19											
A 20											
A 21											
A 22											
A 23											
A 24											
A 25											
A 26											
A 27											
A 28											
A 29											
A 30											
A 31											
A 32											

---

## 6 Specifications

---

### 6.1 Technical Specifications

Function:	Real time clock
Display modes:	12 or 24 hour clock , date or number of days display
Clock synchronisation:	50Hz mains, 60Hz mains, internal clock reference, optional high accuracy crystal or optional GPS satellite synchronisation
Retention:	Display will blank during periods of no power - battery backed clock chip keeps time during these periods
Accuracy:	50 or 60Hz mains sync. - accurate to mains frequency. Where mains frequency is controlled this gives a typical accuracy of $\pm 1$ sec. Internal clock chip - $\pm 30$ sec. per month. Optional high accuracy crystal - $\pm 3$ sec. per month. GPS - accurate to GPS system $\pm 0.1$ sec.
Microprocessor:	MC68HC11 CMOS
Ambient temperature:	-10 to 60°C,
Humidity:	5 to 95% non condensing
Power Supply:	AC 240V, 110V 50/60Hz or DC 12 to 48V isolated or DC 24V ( $\pm 10\%$ ) non isolated Supply type is factory configured
Outputs:	2 x Setpoint relays, form A, rated 5A at 240VAC
Power Consumption:	AC supply 15 VA max, DC supply typically less than 10VA, 3A peak
Sensor DC supply:	Regulated 5VDC or unregulated 18 to 24VDC (link selectable) @ 50mA max. Note: for instruments powered from non isolated DC the 18V unregulated supply will be slightly less than the power supply voltage.

### 6.2 Options

Remote pushbutton socket:	6 way RJ48 socket for remote <b>P</b> , <b>F</b> , <b>▲</b> and <b>▼</b> pushbuttons
Temperature sensor:	Circuit board to accept LM335 sensor
Serial Communications:	RS232 input for synchronisation RS485 input for synchronisation
Clock synchronisation:	10MHz high accuracy clock crystal GPS satellite synchronisation

### 6.3 Physical characteristics

Models LD-RTC-X-100E4 100mm 4 digit electromagnetic	Case size (mm) = 450 x 250 x 155 Weight: = 8.5 kgs Mounting hole locations - see "Mechanical Installation" chapter
Models LD-RTC-X-100E5 100mm 5 digit electromagnetic	Case size (mm) = 520 x 250 x 155 Weight: = 9.5 kgs Mounting hole locations - see "Mechanical Installation" chapter
Models LD-RTC-X-100E6 100mm 6 digit electromagnetic	Case size (mm) = 650 x 250 x 155 Weight: = 10.5 kgs Mounting hole locations - see "Mechanical Installation" chapter
Model LD-RTC-X-38R6 38mm 6 digit LED	Case size (mm) = 255 x 145 x 125 Weight: = 1.3 kgs Mounting hole locations (mm) - see "Mechanical Installation" chapter
Model LD-RTC-X-45R5 45mm 5 digit LED	Case size (mm) = 255 x 145 x 125 Weight: = 1.3 kgs Mounting hole locations (mm) - see "Mechanical Installation" chapter

Model LD-RTC-X-57R4 57mm 4 digit LED	Case size (mm) = 255 x 145 x 125 Weight: = 1.3 kgs Mounting hole locations (mm) - see "Mechanical Installation" chapter
Model LD-RTC-X-100R4 100mm 4 digit LED	Case size (mm) = 450 x 250 x 155 Weight: = 8.5 kg Mounting hole locations (mm) - see "Mechanical Installation" chapter
Model LD-RTC-X-100R6 100mm 6 digit LED	Case size (mm) = 650 x 250 x 155 Weight: = 10.5 kg Mounting hole locations - see "Mechanical Installation" chapter
Model LD-RTC-X-200R4 200mm 4 digit LED	Case size (mm) = 850 x 360 x 130 Weight: = 12 kg Mounting hole locations - see "Mechanical Installation" chapter

---

## Appendix - Serial communications

---

### RS232/485 Operation and Commands

The RS232/485 interface is user selectable. The modes of operation available are as follows:-

***NONE*** - No output:

No output required. Use this setting if a GPS is connected.

#### ***d. SP*** - Image Display Mode:

In image display mode the display value is sent via RS232/485 as raw data in the following format:

<ESC> IXYYYY

Where: <ESC> is the ESCAPE character (27 Dec, 1B Hex)

I is the character 'I' (73 Dec, 49 Hex)

X is the number of image bytes in ASCII (31 to 38 Hex)

YYYY is the raw, 8 bit display data.

This information is output every display update (approx. 4 times per second - depending upon baud rate). The number of image bytes sent depends on the number of display digits present.

The most common usage would be to provide output for a large digit display for wide area viewing which just mimics the smaller display on the measuring instrument. The large digit displays automatically detect the image mode data and display the correct value accordingly. The data is in seven segment display image i.e. Bit 0 is segment A, Bit 1 is segment B, Bit 7 is decimal point etc.

#### ***Cont*** - Continuous Transmit Mode (ASCII):

In this mode the display value is continually sent via the RS232/485 interface every display update (approx. 4 times per second depending on the baud rate). The format for this is as follows:-

<STX> XYYYY<CR>

Where: <STX> is start of text character (2 Dec, 02 Hex)

X SPACE (32 Dec, 20 Hex) for a positive value.

X '-' (45 Dec, 2D Hex) for a negative value.

YYYY is the display value in ASCII (length depends on number of display digits).

<CR> is a Carriage Return (13 Dec, 0D Hex)

e.g.: If the display is showing 123456 then the instrument will send  
'02 20 31 32 33 34 35 36 0D' (HEX) to the host.

#### ***UPdt*** - Update mode.

This mode is used when the LD-RTC is used as a master clock in a master/slave clock system. The master clock will automatically update any other slave clocks attached to it via serial communications. All slave displays must be set to operate in ***POLL*** mode.

#### ***POLL*** - Host Controlled Transmit Mode (ASCII):

This mode requires a host computer or PLC to poll the instrument to obtain display or other information. The format for the host command is as follows:-

<STX>CA<CR> (Standard read etc.)

Where: <STX> is Start of Text Character (2 Dec, 02 Hex)

C is the command character (see list below)

A is the unit address (Range: 32 to 63 Dec, 20 to 3F Hex - address is offset by 32 Dec, 20 Hex)

<CR> is Carriage Return (13 Dec, 0D Hex)

**The POLL commands available and instrument responses are as follows:**

**Transmit Primary Display Value: <STX>PA<CR>**

Instructs unit to return the primary display value. The primary value is the main reading on the display i.e. the time. Format of returned data is:-

<ACK>PAXYYYY<CR>

Where: <ACK> is Acknowledge (6 Dec, 06 Hex)

P echo command received 'P' (80 Dec, 50 Hex)

A is the responding unit's address

X SPACE for positive and '-' for negative

YYYY is the display value in ASCII

<CR> is a Carriage Return (13 Dec, 0D Hex)

The number of display characters returned depends on the number of display digits present. If the decimal point is non zero then it will be sent in the appropriate place as '.' (46 Dec, 2E Hex).

**Transmit Secondary Display Value: <STX>SA<CR>**

Instructs unit to return the secondary display value. In the LD-RTC the secondary display value returned will be the number of seconds elapsed during the current day to one decimal point since midnight.

<ACK>SAYYYYY.Y<CR>

Where:<ACK> is Acknowledge (6 Dec, 06 Hex)

S echo command received 'S' (83 Dec, 53 Hex)

A is the responding unit's address

X is SPACE for positive and '-' for negative

YYYYY.Y is the number of seconds since midnight value in ASCII

<CR> is a Carriage Return (13 Dec, 0D Hex)

The number of display characters returned depends on the number of display digits present. If the decimal point is non zero then it will be sent in the appropriate place as '.' (46 Dec, 2E Hex).

If the instrument does not have a secondary display then the command will be echoed back with no display value (i.e.: <ACK>SA<CR>).

**Transmit Instrument Model and Version: <STX>IA<CR>**

Instructs unit to return the model and version number of the instrument. Format of returned data is:-

<ACK>IACCX.X<CR>

Where: <ACK> is Acknowledge (6 Dec, 06 Hex)

I is echo command received 'I' (73 Dec, 49 Hex)

A is the responding unit's address

CC a 2 character model identifier (e.g.: TC - thermocouple)

X.X is the version number (e.g.: '0.1')

<CR> is a Carriage Return (13 Dec, 0D Hex)

**Invalid Command**

If the command received from the host is not valid then the unit will return the following:-

<ACK>?A<CR>

Where: <ACK> is Acknowledge (6 Dec, 06 Hex)

? is the character '?' (63 Dec, 3F Hex)

A is the responding unit's address

<CR> is a Carriage Return (13 Dec, 0D Hex)

If the address received from the host does not match the units address then the unit will not respond at all.

Other commands may be added to suit the particular configuration of each instrument. Value read commands will have the same format as the Transmit Primary Value command. Set Value commands will have the same format as the Set Low Alarm Setpoint command etc.

**SEF. 1** - Output mode for serial port 1

Displays and sets the output mode for serial port 1. Options are:

**NONE** - no serial input/output

**R232** - RS232 serial input/output

**R485** - RS485 serial input/output

**I 20** - 20mA serial current loop

Where a serial input/output is being used the option must be set to correspond to the input/output hardware fitted. e.g. if the instrument was ordered with an RS232 output then **SEF. 1** (and/or **SEF. 2**) must be set to **R232**.

**SEF. 2** - Output mode for serial port 2

Displays and sets the output mode for serial port 2. Options are as per **SEF. 1**. Not applicable to this instrument.

**Host Timing Requirements for RS485 Operation:**

RS485 operation requires the host to switch the RS485 transceiver to transmit before a command is sent. The instrument is capable of replying after 1 to 2 milliseconds. Therefore the host should switch the RS485 transceiver back to receive mode within 0.5 milliseconds after the last character of the command has been sent to ensure correct operation.

---

## **Guarantee and Service**

---

The product supplied with this manual is guaranteed against faulty workmanship for a period of 2 years from the date of dispatch.

Our obligation assumed under this guarantee is limited to the replacement of parts which, by our examination, are proved to be defective and have not been misused, carelessly handled, defaced or damaged due to incorrect installation. This guarantee is VOID where the unit has been opened, tampered with or if repairs have been made or attempted by anyone except an authorised representative of the manufacturing company.

Products for attention under guarantee (unless otherwise agreed) **must be returned to the manufacturer freight paid** and, if accepted for free repair, will be returned to the customers address in Australia free of charge.

When returning the product for service or repair a full description of the fault and the mode of operation used when the product failed must be given.

In any event the manufacturer has no other obligation or liability beyond replacement or repair of this product.

Modifications may be made to any existing or future models of the unit as it may deem necessary without incurring any obligation to incorporate such modifications in units previously sold or to which this guarantee may relate.

**This document is the property of  
the instrument manufacturer  
and may not be reproduced in whole or part without the  
written consent of the manufacturer.**

**This product is designed and manufactured in Australia.**