

**LD-232, LD-485 & LD-CL**  
**Electromagnetic 39mm Display**

Serial Input (RS232, RS485 or  
serial current loop)

Large Digit Electromagnetic Display  
Operation & Instruction Manual



---

# Table of Contents

---

<b>Introduction</b> . . . . .	<b>3</b>
Meter setup . . . . .	4
<b>Mechanical Installation</b> . . . . .	<b>5</b>
<b>Electrical Installation</b> . . . . .	<b>6</b>
Serial communications connections . . . . .	6
Power supply connections . . . . .	7
Relay connections . . . . .	7
Remote input connections . . . . .	7
DC supply connections . . . . .	7
<b>Explanation of Functions - Non Arithmetic Mode.</b> . . . . .	<b>8</b>
Examples . . . . .	15
<b>Function table</b> . . . . .	<b>17</b>
ASCII Code Conversion Listing . . . . .	19
<b>Explanation of Functions - Arithmetic Mode.</b> . . . . .	<b>20</b>
Examples . . . . .	23
<b>Function Table - Arithmetic Mode</b> . . . . .	<b>24</b>
<b>Display Character Set</b> . . . . .	<b>26</b>
<b>Specifications</b> . . . . .	<b>27</b>
Technical Specifications . . . . .	27
Physical Characteristics . . . . .	27
<b>Guarantee and Service</b> . . . . .	<b>28</b>

---

# 1 Introduction

---

This manual contains information for the installation and operation of the 39m 4 or 6 digit electromagnetic display version of the LD-232, LD-485 or LD-CL serial input (RS232, RS485 or serial current loop) Monitor.

The LD accepts ASCII characters with selectable baud rate and parity. As a simple example using the default settings in the instrument the message 1234<CR> sent in ASCII to the display will result in a display of **1234**. See sections 4.1 and 6.1 for further examples.

The digital display will indicate numeric and some alpha characters (when alpha function is selected). Two standard inbuilt relays are provided for alarm/control functions.

The instrument can operate as a standard serial input display or can operate in arithmetic mode. In arithmetic operation mode the instrument can be programmed to accept input from up to eight RS485 sources and combine these arithmetically. The LD polls the external sources to obtain data for arithmetic manipulation, the external sources must be instruments of the same manufacture.

In other modes the instrument has the ability to transmit periodic polling requests of up to 8 characters in length to obtain data from a single external source. The time between polling requests is programmable from 0.0 to 20.0 seconds. The polling feature allows the LD to request data from sources which require a polling command before data can be transmitted.

Unless otherwise specified at the time of order, your LD has been factory set to a standard configuration. Like all other LD series instruments the configuration and setup is easily changed by the user.

The LD series instruments are designed for high reliability in industrial applications.

## 1.1 Meter setup

The LD setup and calibration functions are configured through a push button sequence. Two levels of access are provided for setting up and calibrating:-

**FUNC** mode (simple push button sequence) allows access to commonly set up functions such as alarm setpoints. **CAL** mode (power up sequence plus push button sequence) allows access to all functions including calibration parameters.

The three push buttons are located on the main circuit board, the front cover will need to be removed to gain access to the pushbuttons. Once **CAL** or **FUNC** mode has been entered you can step through the functions by pressing and releasing the **F** push button until the required function is reached. Changes to functions are made by pressing the **▲** or **▼** push button (in some cases both simultaneously) when the required function is reached. Changes to function settings will not be accepted and stored in memory until the **F** button is pressed to accept the change.

### Entering **CAL** Mode

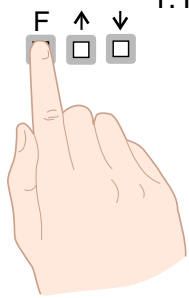

1. Remove power from the instrument and wait 5 seconds. Hold in the **F** button and reapply power. The display will indicate **CAL** as part of the "wake up messages" when the **CAL** message is seen you can release the button. Move to step 2 below.

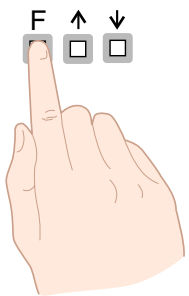

2. When the "wake up" messages have finished and the display has settled down to its normal reading press, then release the **F** button. Move to step 3 below.

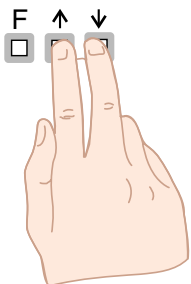

3. Within 2 seconds of releasing the **F** button press, then release the **▲** and **▼** buttons together. The display will now indicate **FUNC** followed by the first function.

Notes: If step 1 above has been completed then the instrument will remain in this **CAL** mode state until power is removed. i.e. there is no need to repeat step 1 when accessing function unless power has been removed.

The instrument should show all 8's on power up e.g. **8.8.8.8**. if the instrument does not reset then these numbers will not be seen. Switch off the instrument and allow a longer time delay before powering up again.

### Entering **FUNC** Mode

No special power up procedure is required to enter **FUNC** mode.

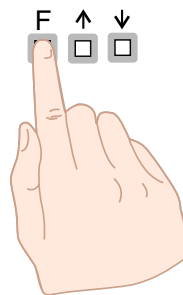

1. When the "wake up" messages have finished and the display has settled down to its normal reading press, then release the **F** button. Move to step 2 below.

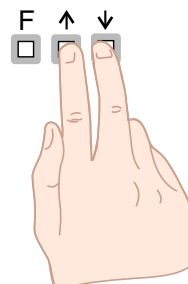

2. Within 2 seconds of releasing the **F** button press, then release the **▲** and **▼** buttons together. The display will now indicate **FUNC** followed by the first function.

## 2 Mechanical Installation

The instruments are designed be wall mounted but an optional panel mount kit is available for the 39mm 4 & 5 digit display models.

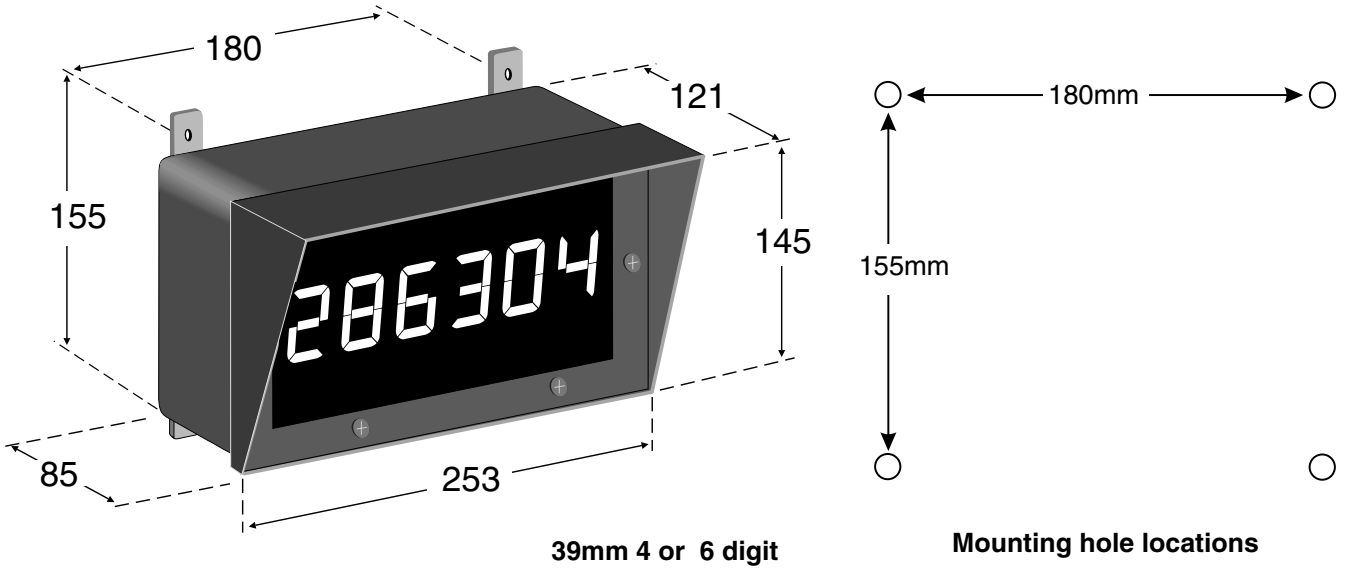

Cut out details optional panel mount kit are shown below.

FRONT VIEW - INSTRUMENT SHOWN WITH HOOD REMOVED (OPTIONAL)

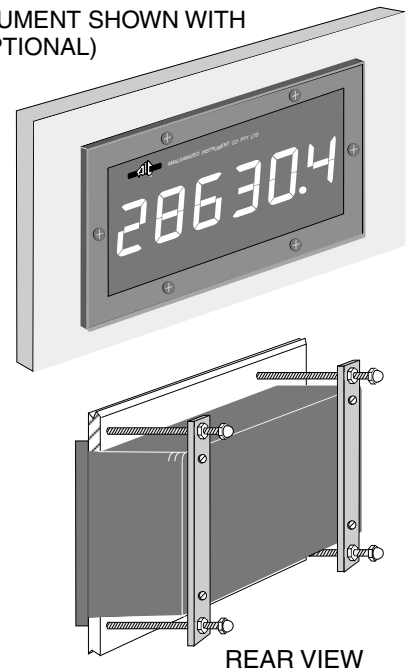
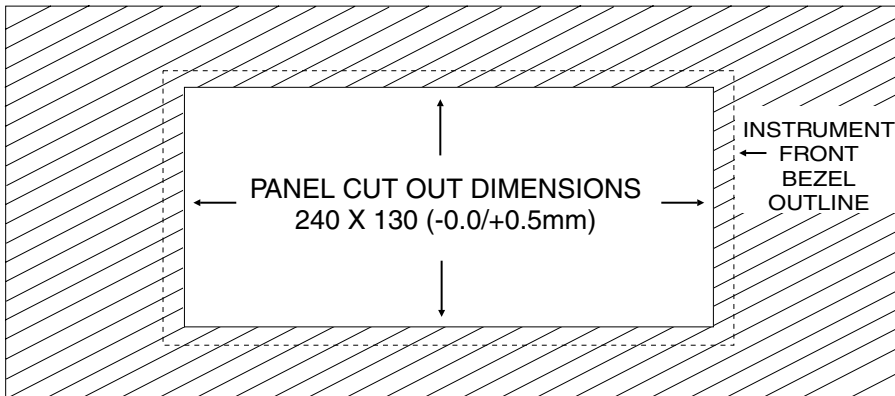

# 3 Electrical Installation

The LD instrument is designed for continuous operation and no power switch is fitted to the unit. It is recommended that an external switch and fuse be provided to allow the unit to be removed for servicing.

The terminal blocks, which are the plug in type for ease of installation, allow for wires of up to 1.5mm<sup>2</sup> (2.5mm<sup>2</sup> for relay connections) to be fitted. Connect the wires to the appropriate terminals as indicated below. Refer to other details provided in this manual to confirm proper selection of voltage, polarity and input type before applying power to the instrument. When power is applied the instrument will cycle through a display sequence, indicating the software version and other status information, this indicates that the instrument is functioning.

## MAIN CIRCUIT BOARD LAYOUT (PARTIAL VIEW)

Main circuit board - partial view

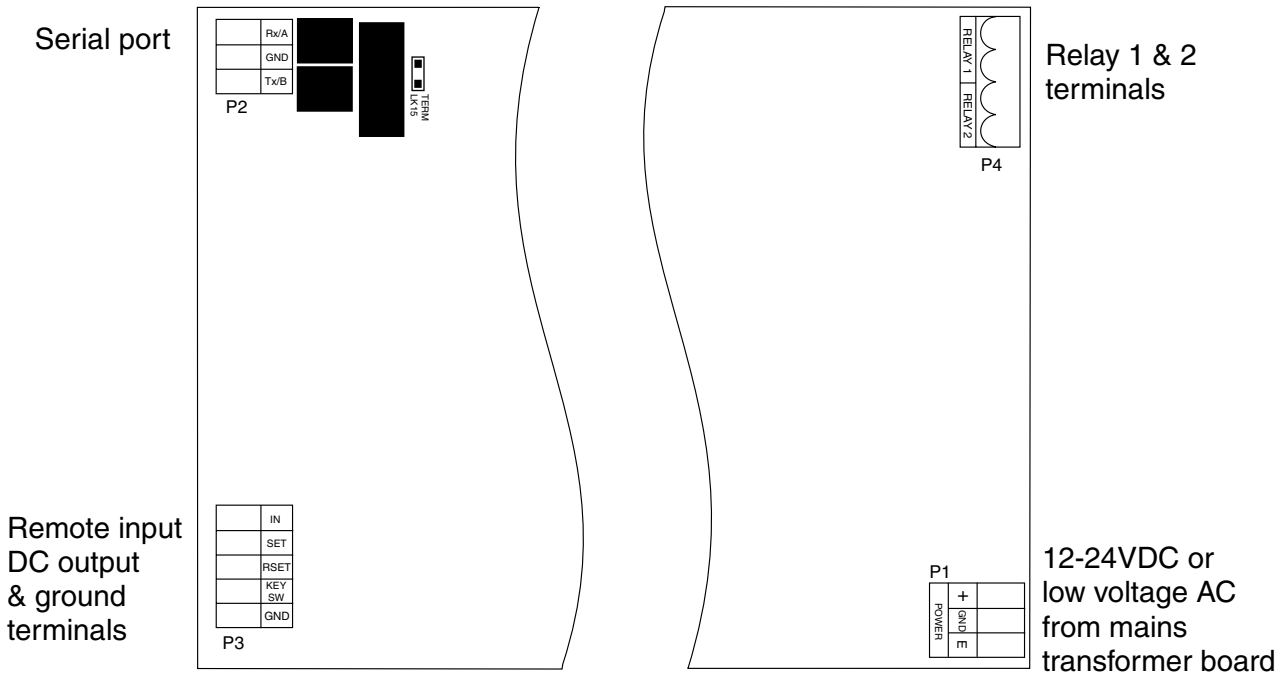

### 3.1 Serial communications connections

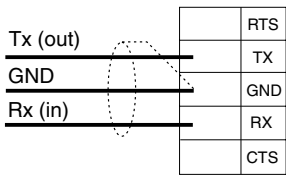

RS232 communications use 3 core shielded cable

NOTE: WHEN CONNECTING USING RS232 THE Tx LINE AT THE LD4 CONNECTS TO THE Rx LINE AT THE DEVICE IT IS COMMUNICATING WITH. LIKewise THE Rx LINE AT THE LD4 CONNECTS TO Tx. WHEN USING RS485 CONNECTIONS ARE A TO A AND B TO B

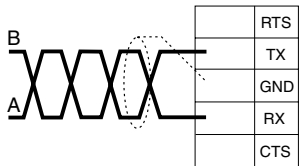

RS485 communications use twisted pair shielded cable

RS485 TERMINATING LINK. THE LINK SHOULD BE IN FOR LONG CABLE RUNS. IF MULTIPLE INSTRUMENTS ARE CONNECTED INSERT THE LINK IF THE LD4-TR IS THE FIRST AND LAST UNIT ON THE LINE.

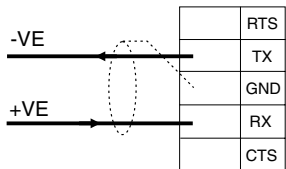

20mA serial current loop communications, use 2 core shielded cable

### 3.2 Power supply connections

Mains power connections (240VAC or 110VAC ) are via a plug in terminals on a transformer board with screw connections (2.5mm<sup>2</sup> for mains input 1.5mm<sup>2</sup> for low voltage AC output). The transformer low voltage AC output goes to the power supply connector P1 on the main circuit board via the lead supplied.

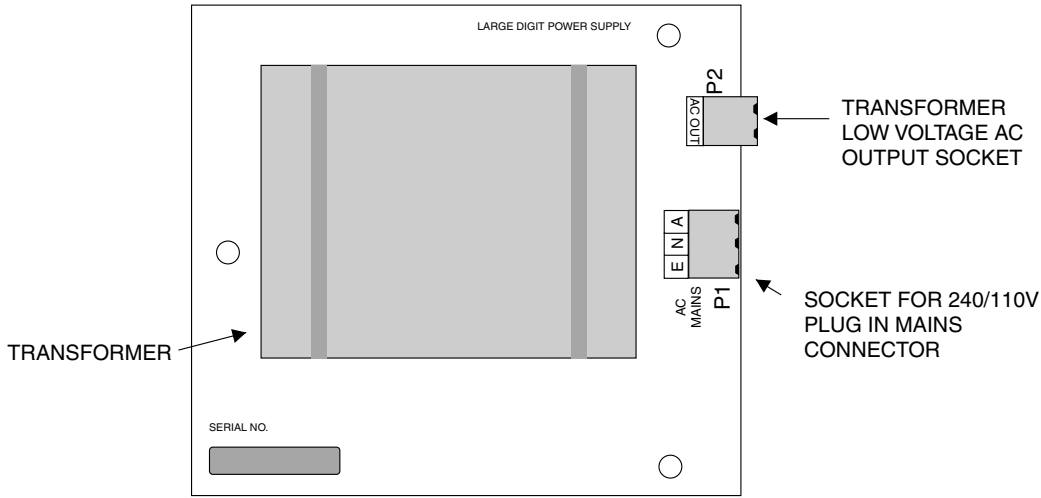

DC supplies may be connected directly to the main circuit board power supply connector via the plug in connector terminals at P1 (1.5mm<sup>2</sup>).

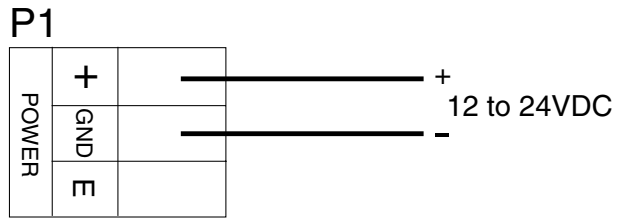

### 3.3 Relay connections

The LD is supplied with two alarm relays as standard with connections on P4. The relays are single pole, single throw types and are rated at 5A, 240VAC into a resistive load. The relay contact is voltage free and may be programmed for normally open or normally closed operation.

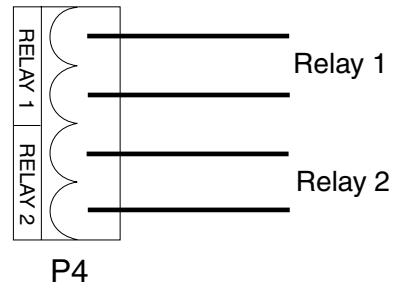

### 3.4 Remote input connections

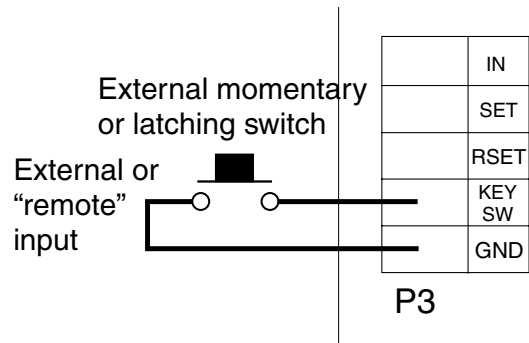

### 3.5 DC supply connections

Note: 25mA max.

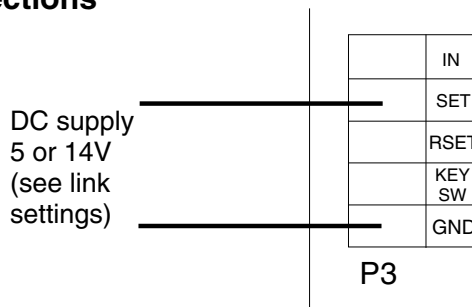

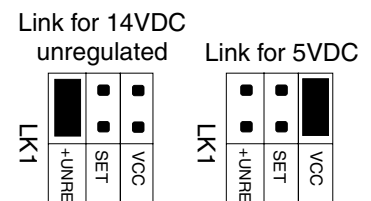

Note: Other links in this group have no use in this instrument





## 4 Explanation of Functions - Non Arithmetic Mode

The functions described below apply when the **Code** function is set to **SP.ASC** or **URL** only, see separate chapter for descriptions of functions seen when the **Code** function is set to **RFTH**.









The alarm and brightness functions below are accessible via **FUNC** mode to gain access to other functions enter via **CAL** mode - see "Introduction" chapter and **ACCS** function.

Changes to functions are made by pressing the  or  push button when the required function is reached. Pressing **F** after a change will enter the changed value into the memory. If **P** is pressed after a change the instrument will revert back to the normal display without saving the change.

The LD has an easy alarm access facility which allows access to the alarm setpoints simply by pressing the **F** button. The first setpoint will then appear and changes to this setpoint may be made to this setpoint via the  or  buttons. Press the **F** button to accept any changes or to move on to the next setpoint.

The instrument must be set in the manner described below to allow the easy access facility to work:

1. The alarm functions will only be seen if the **Code** function is set to **URL**.
2. The **FI NP** function must be set to **SP.AC** or the **ACCS** function set to **EASY**.
3. At least one alarm must have a setpoint, nothing will happen if all the alarm setpoints are set to **OFF**.
4. The **SP.AC** function must be set to allow access to the relays required e.g. if set to **R 1-2** then the easy access will work only with alarm relays 1 and 2 even if more relays are fitted.
5. The instrument must be in normal measure mode i.e. if the instrument is powered up so that it is in **CAL** mode then the easy access will not function. If in doubt then remove power from the instrument, wait for a few seconds then apply power again.
6. If the easy access facility is used then the only way to view or alter any other function settings is to power up via **CAL** mode i.e. there is not entry to **FUNC** mode unless the instrument is powered up in **CAL** mode.

Function	Description
<b>R 1Lo</b>	Alarm relay 1 low setpoint (value or <b>OFF</b> ) - seen only when <b>Code</b> function is set to <b>URL</b> . Displays and sets the alarm 1 low setpoint value. The low alarm setpoint may be disabled by pressing the  and  pushbuttons simultaneously. When the alarm is disabled the display will indicate <b>OFF</b> . Relay 1 will activate when the displayed value is lower than the <b>R 1Lo</b> setpoint value.
<b>R 1H.</b>	Alarm relay 1 high setpoint (value or <b>OFF</b> ) - seen only when <b>Code</b> function is set to <b>URL</b> . Displays and sets the alarm 1 high setpoint value. The high alarm setpoint may be disabled by pressing the  and  pushbuttons simultaneously. When the alarm is disabled the display will indicate <b>OFF</b> . Relay 1 will activate when the displayed value is higher than the <b>R 1H.</b> setpoint value.
<b>R 2Lo</b>	Alarm relay 2 low setpoint (value or <b>OFF</b> ) - seen only when <b>Code</b> function is set to <b>URL</b> . Displays and sets the alarm 2 low setpoint value. The low alarm setpoint may be disabled by pressing the  and  pushbuttons simultaneously. When the alarm is disabled the display will indicate <b>OFF</b> . Relay 2 will activate when the displayed value is lower than the <b>R 2Lo</b> setpoint value.
<b>R 2H.</b>	Alarm relay 2 high setpoint (value or <b>OFF</b> ) - seen only when <b>Code</b> function is set to <b>URL</b> . Displays and sets the alarm 2 high setpoint value. The high alarm setpoint may be disabled by pressing the  and  pushbuttons simultaneously. When the alarm is disabled the display will indicate <b>OFF</b> . Relay 2 will activate when the displayed value is higher than the <b>R 2H.</b> setpoint value.

**A1HY**

Alarm relay 1 hysteresis [deadband] (0 to 9999) - seen only when **Code** function is set to **URL** and either **A1Lo** or **A1Hi** have been set to a value.

Displays and sets the alarm hysteresis limit and is common for both high and low setpoint values. The hysteresis value may be used to prevent too frequent operation of the setpoint relay when the measured value stays close to the setpoint. Without a hysteresis setting (**AxHY** set to zero) the alarm will activate when the display value goes above the alarm setpoint (for high alarm) and will reset when the display value falls below the setpoint, this can result in repeated on/off switching of the relay at around the setpoint value. The hysteresis setting operates as follows:

In the high alarm mode, once the alarm is activated the input must fall below the setpoint value minus the hysteresis value to reset the alarm.

e.g. if **A1Hi** is set to **50.0** and **A1HY** is set to **3.0** then the setpoint output relay will activate once the display value goes above **50.0** and will reset when the display value goes below **47.0** (50.0 minus 3.0).

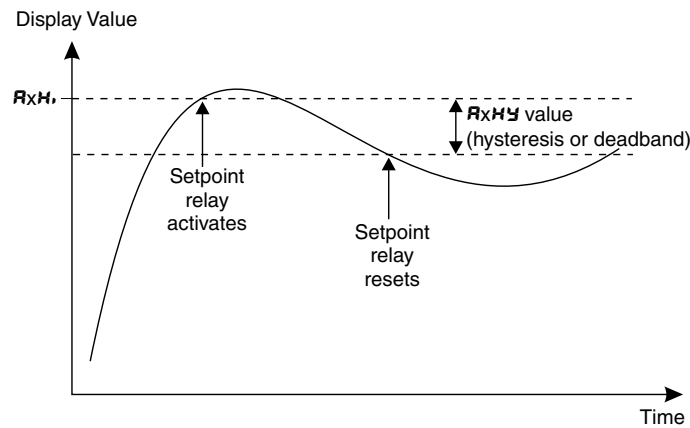

In the low alarm mode, once the alarm is activated the input must rise above the setpoint value plus the hysteresis value to reset the alarm.

e.g. if **A1Lo** is set to **20.0** and **A1HY** is set to **10.0** then the alarm output relay will activate when the display value falls below **20.0** and will reset when the display value goes above **30.0** (20.0 plus 10.0).

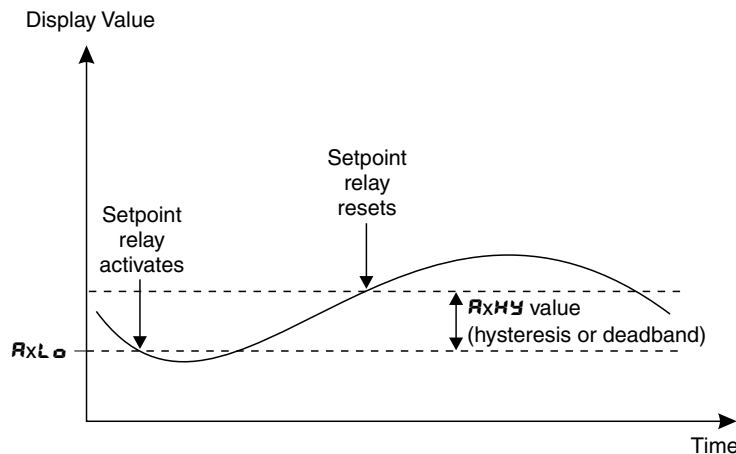

The hysteresis units are expressed in displayed engineering units.

**A2HY**

Alarm relay 2 hysteresis [deadband] (0 to 9999) - seen only when **Code** function is set to **URL** and either **A2Lo** or **A2Hi** have been set to a value.

Displays and sets the alarm 2 hysteresis limit (see **A1HY** for further description).

**A1t**

Alarm relay1 trip time (0 to 60 seconds) - seen only when **Code** function is set to **URL** and either **A1Lo** or **A1Hi** have been set to a value.



Displays and sets the alarm 1 trip time and is common for both alarm 1 high and low setpoint values. The trip time is the delay before the alarm will trip. The alarm condition must be present continuously for the trip time period before the alarm will trip. This function is useful for preventing an alarm trip due to short non critical deviations from setpoint

<b>R2t</b>	Alarm relay 2 trip time (0 to 60 seconds)- seen only when <b>Code</b> function is set to <b>URL</b> and either <b>R2Lo</b> or <b>R2H</b> , have been set to a value. Displays and sets the alarm 2 trip time (other details as per <b>R1t</b> ).
<b>R1r</b>	Alarm relay 1 reset time (0 to 60 seconds) - seen only when <b>Code</b> function is set to <b>URL</b> and either <b>R1Lo</b> or <b>R1H</b> , have been set to a value. Displays and sets the alarm 1 relay reset time. With the alarm condition is removed the alarm relay will stay in its alarm condition for the time selected as the reset time.
<b>R2r</b>	Alarm relay 2 reset time (0 to 60 seconds) - seen only when <b>Code</b> function is set to <b>URL</b> and either <b>R1Lo</b> or <b>R1H</b> , have been set to a value. Displays and sets the alarm 2 relay reset time. With the alarm condition is removed the alarm relay will stay in its alarm condition for the time selected as the reset time. Reset time is selectable over 0 to 60 seconds.
<b>R1no</b> or <b>R1nc</b>	Alarm relay 1 normally open or normally closed - seen only when <b>Code</b> function is set to <b>URL</b> and either <b>R1Lo</b> or <b>R1H</b> , have been set to a value. Displays and sets the alarm relay 1 action to normally open (de-energised) or normally closed (energised), when no alarm condition is present.
<b>R2no</b> or <b>R2nc</b>	Alarm relay 2 normally open or normally closed - seen only when <b>Code</b> function is set to <b>URL</b> and either <b>R1Lo</b> or <b>R1H</b> , have been set to a value. Displays and sets the alarm relay 2 action to normally open (de-energised) or normally closed (energised), when no alarm condition is present.
<b>R2SP</b> or <b>R2t1</b>	Alarm relay 2 operation independent setpoint or trailing - seen only when <b>Code</b> function is set to <b>URL</b> and either <b>R1Lo</b> or <b>R1H</b> , have been set to a value. Alarm relay 2 may be programmed to operate with an independent setpoint setting or may be linked (or trailing) to operate at a fixed difference to relay 1 setpoint. Alarm 1 ( <b>R1</b> ) is always independent. Select <b>R2SP</b> for an independent setting or <b>R2t1</b> for a trailing setpoint. For trailing set points, the setpoint value is entered as the difference from the alarm 1 setpoint. If the trailing setpoint is to operate ahead of alarm 1 then the value is entered as a positive number and if operating behind alarm 1 setpoint then the value is entered as a negative number. For example, with Alarm 2 set to trail alarm 1, if <b>R1H</b> , is set to 1000 and <b>R2H</b> , is set to 50 then Alarm 1 will trip at 1000 and alarm 2 will trip at 1050 (i.e. 1000 + 50). If Alarm 2 had been set at -50 then alarm 2 would trip at 950 (i.e. 1000 - 50). For trailing operation both relays must be set to the same mode i.e. either both set for low ( <b>R1Lo</b> & <b>R2Lo</b> ) or both set to high ( <b>R1H</b> , & <b>R2H</b> , ).
The following functions can only be viewed when the instrument is powered up in <b>CAL</b> mode, see the first page of this chapter for details or if the <b>ACCS</b> function is set to <b>ALL</b> .	
<b>drnd</b>	Display rounding ( 1 to 5000 display units) - seen only when <b>Code</b> function is set to <b>URL</b> . Displays and sets the display rounding value. This value may be set from 1-5000 displayed units (e.g. 0.00 1 to 5.000 if decimal point set to 3 places). Display rounding is useful for reducing the instrument resolution without loss of accuracy in applications where it is undesirable to display to a fine tolerance. (example: if set to 10 the instrument display will increment in multiples of 10). The display rounding will also affect the alarm setpoint settings in that the alarms will also operate on multiples of the display rounding figure.
<b>dCPt</b>	Period decimal point selection (0, 0. 1, 0.02 etc) - seen only when <b>Code</b> function is set to <b>URL</b> . Displays and sets the decimal point position on the display. <b>Note:</b> electromagnetic displays require the decimal point to be mechanically fixed in position, the decimal point functions are included for compatibility with incoming data which includes decimal points. For example selecting 0 will mean no decimal points (e.g. a display such as 25), 0. 1 means 1 decimal point place (e.g. 25.4), 0.02 gives 2 decimal point places (e.g. 25.35) etc. The maximum number of decimal point places is one less than the number of digits on the display e.g. a 4 digit display can have 3 decimal points, a 6 digit display can have 5 decimal points etc.
<b>FLtr</b>	Digital filter - seen only when <b>Code</b> function = <b>URL</b> . Displays and sets the digital filter value. Digital filtering is used for reducing susceptibility to short term interference such as electrical noise, interference is normally seen as unwanted display variations from the expected value. The digital filter range is selectable from 0 to 8, where 0 = none and 8 = most filtering. The higher the filter setting the slower the display update. A typical value for the digital filter would be 3.

<b>Code</b>	<p>Select data type for display (<b>ASCII</b>, <b>URL</b>, <b>d</b>, <b>SP</b> or <b>ARth</b>)</p> <p>One of three different data types or one special display mode can be selected in this function:</p> <p><b>ASCII</b> selects ASCII type input data, the input data will then be displayed without modification (see also <b>ALPH</b> function as this can also affect what is displayed). Displays of characters in <b>ALPH</b> mode are left justified. In ASCII mode any leading zeroes in the message will be displayed.</p> <p><b>URL</b> is the “value” or numeric mode. The incoming characters will be converted to a numeric value, the characters will be read until a terminating character (see <b>echr</b>) is found. Once the termination character is found the numeric value will be updated and displayed. If a non numeric character is found then the conversion will cease at that point. The numeric value is filtered after conversion the <b>FLtr</b> setting determines the level of filtering. Characters treated as numeric include &lt;SPACE&gt;, ‘+’, ‘-’, ‘.’ and numbers 0 to 9. <b>URL</b> mode ignores leading zeroes i.e. a leading zero will be displayed as a blank digit.</p> <p>With <b>d</b>, <b>SP</b> selected (image mode) the display expects to see and input in raw data format from another instrument. This mode is only used when the display is connected to an instrument of the same manufacture.</p> <p>The data format expected is: &lt;ESC&gt;Incccc  Where: &lt;ESC&gt; is 27 Dec or 1B Hex  I is the ASCII character “I”  n is the number of image characters to follow  cccc are the image characters</p> <p><b>ARth</b> selects arithmetic mode - see “Explanation of Functions - Arithmetic Mode” chapter.</p> <p><b>PLA</b> - special operation mode, not applicable to this manual</p>
<b>RIOPER</b>	<p>Relay 1 operation mode (<b>IPLE</b> or <b>LOUL</b>) - relay 1 can be made to operate from the input value (e.g. at the <b>RILO</b> or <b>RIH</b>, value, applicable when <b>Code</b> is set to <b>URL</b> or when the display blanks due to the timeout value being exceeded (timeout value set at the <b>dSto</b> function).</p>
<b>SCH1</b>	<p>Start of text character 1 (<b>-2</b> to <b>255</b>), used for addressing multidrop displays or selecting required display from a string.</p> <p>When a string is sent the instrument will look for three start of text characters, <b>SCH1</b>, <b>SCH2</b> and <b>SCH3</b>. If these character do not appear, one after the other, then the string of data will not be accepted and will not be displayed. Selecting <b>-1</b> disables the <b>SCH</b> and no matching will be required for that character. Selecting <b>-2</b> for means ‘don’t care’ and any character will be taken as a match (note that a missing character will not constitute a match). <b>SCH1</b> is the first start of text character, <b>SCH2</b> and <b>SCH3</b> characters can also be used to give up to 3 start of text characters. For example with <b>SCH1</b> set to <b>2</b>, <b>SCH2</b> set to <b>106</b> and <b>SCH3</b> set to <b>103</b> data will only be displayed if it is proceeded by “&lt;STX&gt;kg” characters since 02 (decimal) is the ASCII &lt;STX&gt; control character, 106 (decimal) is the ASCII “k” character and 103 (decimal) is the “g” ASCII character.</p> <p>See “5.1 ASCII Code Conversion Listing” for a full listing of ASCII codes and “Examples” later in this chapter for a full listing.</p>
<b>SCH2</b>	<p>Start of text character 2 (<b>-2</b> to <b>255</b>)  <b>SCH2</b> is the second start of text character. See <b>SCH1</b> for details.</p>
<b>SCH3</b>	<p>Start of text character 3 (<b>-2</b> to <b>255</b>)  <b>SCH3</b> is the third start of text character. See <b>SCH1</b> for details.</p>
<b>echr</b>	<p>Terminating character (<b>-1</b> to <b>255</b>)</p> <p>Terminating character, default setting is <b>13</b> [carriage return &lt;CR&gt;]. This character is recognised as the end of transmission for a input data stream. The next character received will be interpreted as the start of the next input stream. A setting of <b>-1</b> means the LD will expect no terminating character.</p>

<b>dLAY</b>	<p>Number of characters to skip (<b>0</b> to <b>200</b>).</p> <p>Select the numbers of characters to skip before displaying (may be set from <b>0</b> to <b>200</b>, default is <b>0</b> [off]). This allows the display to skip a certain number of characters in the input stream before starting the display. This is useful for skipping control characters etc, which may be sent by the instruments along with the display information.</p>
<b>bRct</b>	<p>Number of character back (<b>0</b> to <b>10</b>).</p> <p>Number of characters, back from the terminating character, to display (set from <b>0</b> to <b>10</b>, default is <b>0</b> [off]). The display will wait for the terminating character and will then display the last X number of characters, depending on the value set in this function. For example if the terminating character is set to carriage return &lt;CR&gt; and <b>bRct</b> is set to 4 then <b>4567</b> (the 4 characters back from &lt;CR&gt; will be displayed from the following example string:  <pre>&lt;STX&gt;A3 1234567&lt;CR&gt;</pre> </p>
<b>nChr</b>	<p>Number of characters from <b>SCN 1</b> (<b>0</b> to <b>10</b>)</p> <p>Normally used only in special applications and operates in a similar manner to the <b>dLAY</b> function. In most circumstances the <b>dLAY</b> or <b>bRct</b> function would be used in preference to this function. If the length of the input data string is likely vary, or the position of the required display data can vary in the string, but the required data to be displayed is always a set number of bytes away from a constant character which can be used as the <b>SCN 1</b> character then the <b>nChr</b> function can be used instead of the <b>dLAY</b> function. This function sets the number of characters to be extracted from the data string immediately following the <b>SCN 1</b> character. If this function is not required it should be left at the default setting of <b>0</b> which will disable the function.</p>
<b>i dPt</b>	<p>Input string decimal point (<b>- 1</b> to <b>8</b>)</p> <p>Normally used only in special applications using customised software when non standard arithmetic operations on the input data are required. In some systems the transmitting unit may display a decimal point position but not transmit the decimal point as part of the serial data. The <b>i dPt</b> can be used to inform the LD display of the position of the decimal point, this information is then used in any arithmetic operations to calculate a result. The decimal point position of the result shown on the LD display is set via the <b>dCPt</b> function. If the <b>i dPt</b> function is not needed then it should be left at the default setting of <b>- 1</b> which will disable the function.</p>
<b>ALPH</b>	<p>Alpha character enable (<b>ON</b> or <b>OFF</b>).</p> <p>Set this function to <b>OFF</b> to filter alpha characters from the input stream i.e. only numeric characters will be displayed and alpha characters ignored. When set to <b>ON</b> the instrument will display both alpha and numeric characters. Note: only a limited number of alpha characters may be displayed, due to the nature of 7 segment displays, non displayable characters (e.g. W and X) will be ignored. Default setting is <b>OFF</b>.</p>
<b>POLL i nPt</b>	<p>Polling function (<b>on</b> or <b>OFF</b>) - seen only when <b>Code</b> function is set to <b>URL</b> or <b>ASCII</b>.</p> <p>The LD has the ability to transmit up to eight characters for polling purposes. The characters are set by functions <b>Pch. 1</b> to <b>P.ch8</b> and the repeat rate for this polling is set by the <b>POLL dLAY</b> function. If <b>POLL i nPt</b> is set to <b>OFF</b> then no characters will be transmitted and the other polling functions will not be seen. If set to <b>on</b> then the characters selected will be transmitted at the rate selected by the <b>POLL dLAY</b> function. This ability to poll is used when the LD display is to display data from a source which requires a polling command before it will communicate. See “Examples” at the end of this chapter for polling examples.</p>
<b>POLL dLAY</b>	<p>Polling delay time (<b>0.0</b> to <b>20.0</b> seconds) - seen only when <b>Code</b> function is set to <b>URL</b> or <b>ASCII</b> and <b>POLL i nPt</b> function is set to <b>on</b>.</p> <p>When the polling facility is being used the <b>POLL dLAY</b> function sets the repeat rate, in seconds, of the poll command. The time may be set from 0.0 seconds (continuous) to 20.0 seconds. Note in electromagnetic displays the decimal point may or may not be in place, a display of <b>200</b> will mean 20.0 seconds. See “Examples” at the end of this chapter for polling examples.</p>

<b>Pch 1</b>	<p>First poll command character ( - 1 to 255) - seen only when <b>Code</b> function is set to <b>URL</b> or <b>RSC</b> and <b>POLL:NPt</b> function is set to <b>on</b>.</p> <p>Each of the eight poll command characters can be set from - 1 to 255 decimal. If set to - 1 then the character is ignored, if set to any other number then the equivalent ASCII character for that number will be sent (refer to section 5.1 for ASCII code conversion table). Characters 0 to 31 are special control characters such as “carriage return” and “start of text”. Use as many <b>Pch</b> characters as required by your system and set the remaining characters to - 1 so that they are ignored. See “Examples” at the end of this chapter for polling examples.</p>
<b>Pch2 to Pch8</b>	<p>Second, third etc. poll command characters ( - 1 to 255) - see <b>Pch 1</b> above for details.</p>
<b>dSto</b>	<p>Set the display timeout value (0 to 9999 seconds).</p> <p>This function allows the user to set a timeout value for a valid display. A setting of 0 disables the timeout. If a new data stream is not received before the timeout value is reached then the display will be blanked.</p>
<b>tout</b>	<p>Set data timeout value (0.0 to 10.0 seconds).</p> <p>This function allows the user to set a timeout value for the data stream. Valid times are 0.0 to 10.0 seconds, a setting of 0.0 disables the timeout. The timeout will cause the current data stream to be ignored if the time gap between characters in the stream exceeds the <b>tout</b> value. This function helps to prevent false displays when the data stream is interrupted.</p>
<b>Pbut</b>	<p>(<b>P</b> button function) - applicable only when <b>Code</b> function = <b>URL</b>.</p> <p>The following applies only when the <b>Code</b> function is set to <b>URL</b>. The <b>P</b> button may be set to operate some of the remote input functions. With the tare function, to prevent accidental operation, the <b>P</b> button must be held pressed for 2-3 seconds before the display will tare, momentary operation of the tare function will cause the gross value to be displayed, preceded by the message <b>GFOS</b>. If both the remote input and <b>P</b> button function are operated simultaneously the <b>P</b> button will override the remote input. The functions below are as described in the <b>F:NP</b> function above with the exception of the <b>P.SET</b> function.</p> <p>Functions available are:  <b>NONE, H, Lo, H, Lo, tARE or ZEF0.</b></p>
<b>F:NP</b>	<p>Remote input function) - functions marked * are applicable to <b>URL</b> mode only and do not work in other modes.</p> <p>Terminals “GND” and “KEY” remote input terminals. When these terminals are short circuited, via a pushbutton or keyswitch, the instrument will perform the selected remote input function. A message will flash to indicate which function has been selected when the remote input pins are short circuited. The remote input functions are as follows:</p> <ul style="list-style-type: none"> <li>* <b>NONE</b> - no remote function required.</li> <li>* <b>PHLd</b> - peak hold. The display will show the peak hold value whilst the remote input terminals are short circuited.</li> <li>* <b>dHLd</b> - display hold. The display will hold its value whilst the remote input terminals are short circuited</li> <li>* <b>H</b> - peak memory. The peak value stored in memory will be displayed if the remote input terminals are short circuited, if the short circuit is momentary then the display will return to normal measurement after 20 seconds. If the short circuit is held for 1 to 2 seconds then the memory will be cleared.</li> <li>* <b>Lo</b> - valley memory. The minimum value stored in memory will be displayed. Otherwise operates in the same manner as the <b>H</b> function.</li> <li>* <b>H, Lo</b> - toggle between <b>H</b> and <b>Lo</b> displays. This function allows the remote input to be used to toggle between peak and valley memory displays. The first operation of the remote input will cause the peak memory value to be displayed, the next operation will give a valley memory display. <b>PH</b>, or <b>PLo</b> will flash before each display to give an indication of display type.</li> </ul>

<p><b>F: NP</b> cont.</p>	<p>* <b>TARE</b> - tare the display. The display will be zeroed when the remote input terminals are short circuited for 2-3 seconds. Momentary operation of the remote input will cause the gross value to be displayed for a few seconds, preceded by the message <b>9F05</b>. If power is removed then the tare will be lost.</p> <p>* <b>ZERO</b> - zero the display. The value on the display at the time of the zero operation will be taken as the zero value at the when the remote input terminals are short circuited. The zero can be cleared via the <b>CLF ZERO</b> function, removal of power will not clear the zero.</p> <p><b>SPAC</b> - setpoint access only. This blocks access to any functions except the alarm setpoint functions unless the remote input terminals are short circuited or entry is made via <b>CAL</b> mode.</p> <p><b>NOAC</b> - no access. This blocks access to all functions unless the remote input terminals are short circuited or entry is made via <b>CAL</b> mode.</p> <p><b>BULL</b> - display brightness control. Not applicable to Electromagnetic displays.</p>
<p><b>ACCS</b></p>	<p>Access mode (<b>OFF</b>, <b>EASY</b>, <b>NONE</b> or <b>ALL</b>) - The access mode function <b>ACCS</b> has four possible settings. If set to <b>OFF</b> the mode function has no effect or alarm relay operation. If set to <b>EASY</b> the "easy alarm access" mode will be in operation, see page 8. If set to <b>NONE</b> there will be no access to any functions via <b>FUNC</b> mode, entry via <b>CAL</b> mode must be made to gain access to alarm functions. If set to <b>ALL</b> then all functions will be accessible via <b>FUNC</b> mode i.e. there is no need to enter <b>CAL</b> mode. This function provides an alternative to using the <b>F: NP</b> function for easy access or no access mode thereby allowing the remote input to be programmed for an alternative use.</p>
<p><b>SPAC</b></p>	<p>Setpoint access (<b>A 1</b> or <b>A 1-2</b>) - seen only when <b>Code</b> function is set to <b>UAL</b>. Sets the access to the alarm relay set points. The following choices are available:  <b>A 1</b> - Allows setpoint access to alarm 1 only.  <b>A 1-2</b> - Allows access to alarms 1 and 2. For the setpoint access function to operate the remote input function (<b>F: NP</b>) must be set to <b>SPAC</b>.</p>
<p><b>CLF ZERO</b></p>	<p>Clear zero - seen only when <b>Code</b> function is set to <b>UAL</b>  Allows any zero operations performed via the <b>F: NP</b> function to be cleared. Pressing the  and  buttons simultaneously will clear the zero.</p>
<p><b>BAUD RATE</b></p>	<p>Baud rate select.  Select from <b>300, 600, 1200, 2400, 4800, 9600, 19.2</b> or <b>38.4</b>.</p>
<p><b>PRTY</b></p>	<p>Parity select.  Select either <b>NONE</b>, <b>EVEN</b> or <b>odd</b>. Default setting is <b>NONE</b>.</p>
<p><b>DATAB</b></p>	<p>Number of data bits (<b>7b, 8</b> or <b>8b, 8</b>).  This function is used to inform the LD display of the number of data bits on the incoming data. Select from either <b>7b, 8</b> for 7 bit (plus 1 stop bit) incoming data or <b>8b, 8</b> if 8 bit (plus 1 stop bit) incoming data is used.</p>
<p><b>SER 1 TYPE</b></p>	<p>Serial communication type.  Select the communication type to be used as either:  <b>NONE</b> - No serial communication  <b>F232</b> - RS232 communication  <b>F485</b> - RS485 communication  <b>I 20</b> - 20mA serial current loop communication  Note: The communication type must match the hardware setup of the instrument e.g. if the instrument is supplied as an RS232 input display then a hardware change and a change to the <b>SER 1 TYPE</b> function will be required for RS485 operation. i.e. the <b>SER 1 TYPE</b> function on its own cannot change the communication type.</p>
<p><b>SER 2 TYPE</b></p>	<p>Second channel serial communication type - not applicable to this software version.</p>

### Returning to the normal measure mode

When the calibration procedure has been completed it is advisable to return the instrument to the normal mode (where calibration functions cannot be tampered with). To return to the normal mode, turn off power to the instrument, wait a few seconds and then restore power.

## 4.1 Examples

Following are some examples of settings for incoming data streams. See the "Function Table" chapter for an ASCII conversion table.

### Example 1

Input string: 3456<CR>

Required display: **3456**

One possible group of settings to achieve the required display is:-

**Code** set to **URL** or **RSC**

**chr** set to **13** (this corresponds to <CR> i.e carriage return)

### Example 2

Input string: <STX>Weight:+1234kg tare<CR>

Required display: **1234**

One possible group of settings to achieve the required display is:-

**SCH 1** set to **2** Decimal (this corresponds to <STX>)

**SCH 2** set to **87** Decimal (this corresponds to W)

**SCH 3** set to **- 1** (disabled)

**Code** set to **URL**

**dLAY** set to **6**

**chr** set to **13** (this corresponds to <CR>)

The matching of all three start of text characters is valid since <STX> appears first followed by W (from Weight) and **SCH 3** is disabled. The 6 characters following the W (eight:) are ignored since **dLAY** is set to 6. The kg characters are ignored since **code** is set to **URL**. The + is taken as a numeric value but is not displayable. The terminating character is set to <CR>.

### Example 3

Input string: <STX>XYZNNM1005kg<ETX>

Required display: **1005**

One possible group of settings to achieve the required display is:-

**SCH 1** set to **2** Decimal (this corresponds to <STX>)

**SCH 2** set to **- 1** (disabled)

**SCH 3** set to **- 1** (disabled)

**dLAY** set to **0**

**ALPH** set to **OFF**

**Code** set to **RSC**

**dCPt** set to **0.02**

**bAct** set to **0**

**chr** set to **3** (this corresponds to <ETX>)

The <STX> character corresponds to **SCH 1**, **SCH 2** & **3** are disabled. All of the alpha characters which follow (XYZNNM and kg) are ignored since **ALPH** is set to **OFF**. The decimal point is set at two places and therefore appears between the two zeroes on the display.

### Example 4

Input string: <STX>X1 ABC 12.34<CR><LF>

<STX>Y2 ABC 56.78<CR><LF>

Required display: **568** with 5 sec. display blanking

One possible group of settings to achieve the required display is:-

**SCH 1** set to **2** Decimal (this corresponds to <STX>)

**SCH 2** set to **- 2** (don't care)

**SCH 3** set to **50** (this corresponds to 2 in ASCII)

**dLAY** set to **1**

**ALPH** set to **OFF**

**Code** set to **URL**

**dCPt** set to **0. 1**

**bAct** set to **0**  
**tchr** set to **13** (this corresponds to <CR>)  
**dSto** set to **5**

The <STX> character corresponds to **SCH 1**, **SCH2** is set to don't care and **SCH3** is set to **2** so the first string is ignored (<STX>Y1 does not match <STX>/don't care/2). The second string does match, all of the alpha characters which follow Y2 (XYZNNM) are ignored since **ALPH** is set to **OFF** (note the kg characters following the numeric values are ignored since **code** is set to **URL**) but the spaces are numeric values so setting **dLAY** to **1** will cause one space to be ignored. The decimal point is set at one place and therefore the displayed number is rounded and shown as one decimal place. The display will blank if there is a 5 second gap between strings due to the **dSto** setting.

#### Example 5

Input string: ABCDXYZGGNNMM100033<CR>

Required display: **1000** on a 4 digit display

If the status characters and desired values are sent as one string then the easiest way to recover the desired values is by using the **bAct** function.

**SCH 1** set to **- 1** (disabled)

**SCH2** set to **- 1** (disabled)

**SCH3** set to **- 1** (disabled)

**dLAY** set to **0**

**Code** set to **ASC**

**dCPE** set to **0**

**bAct** set to **6**

**tchr** set to **13** (this corresponds to <CR>)

The instrument counts back from the <CR> terminating character and displays the numbers starting from 1 in this case.

#### Example 6 - Polling facility setup example.

The LD is connected to a different instrument (must be of the same manufacture) which has serial communications and is set to a polling address of 5. The LD is required to request a primary display value. The request is to be updated every 10 seconds. The polling command required for transmission of the primary display value from this LD is: <STX>P5<CR>

Where: <STX> is the start of text control character, P is the primary display request character, 5 is the unit address and <CR> is the carriage return control character.

The main LD function settings required for this example are:

**Code** = **URL**

**POLL 1 NPt** = **on**

**POLL dLAY** = **10.0**

**Pch 1** = **2** this correspond to <SCH>

**Pch2** = **80** this corresponds to P

**Pch3** = **37** this corresponds to address 5 (32 is address 0)

**Pch4** = **13** this corresponds to <CR>

**Pch5**, **Pch6**, **Pch7** and **Pch8** are all set to **- 1**

#### Example 7 - Polling facility setup example.

The LD is connected to a PLC via a serial link. The PLC requires a polling command of "T?" before it will transmit data to the LD. The application requires that the PLC be polled every 2.5 seconds. The main LD function settings required for this example are:

**Code** = **URL** (or **ASC**) depending on requirements)

**POLL 1 NPt** = **on**

**POLL dLAY** = **2.5**

**Pch 1** = **84** this correspond to T

**Pch2** = **63** this corresponds to ?

**Pch3**, **Pch4**, **Pch5**, **Pch6**, **Pch7** and **Pch8** are all set to **- 1**.

## 5 Function table

Initial display	Meaning of display	Next display	Default Setting	Record Your Settings
# <i>R1Lo</i>	Alarm 1 low setpoint value	Setpoint value or <i>OFF</i>	<i>OFF</i>	
# <i>R1Hi</i>	Alarm 1 high setpoint value	Setpoint value or <i>OFF</i>	<i>1000</i>	
# <i>R2Lo</i>	Alarm 2 low setpoint value	Setpoint value or <i>OFF</i>	<i>OFF</i>	
# <i>R2Hi</i>	Alarm 2 high setpoint value	Setpoint value or <i>OFF</i>	<i>1000</i>	
# <i>R1HY</i>	Alarm 1 hysteresis	Hysteresis value in measured units	<i>1</i>	
# <i>R2HY</i>	Alarm 2 hysteresis	Hysteresis value in measured units	<i>1</i>	
# <i>R1t</i>	Alarm 1 trip time	No of seconds before relay 1 trips	<i>0</i>	
# <i>R2t</i>	Alarm 2 trip time	No of seconds before relay 2 trips	<i>0</i>	
# <i>R1r</i>	Alarm 1 reset time	No of seconds before Relay 1 resets	<i>0</i>	
# <i>R2r</i>	Alarm 2 reset time	No of seconds before relay 2 resets	<i>0</i>	
# <i>R1no</i> or <i>R1nc</i>	Alarm 1 action N/O or N/C	<i>R1no</i> or <i>R1nc</i>	<i>R1no</i>	
# <i>R2no</i> or <i>R2nc</i>	Alarm 2 action N/O or N/C	<i>R2no</i> or <i>R2nc</i>	<i>R2no</i>	
# <i>R2SP</i> or <i>R2t</i>	Alarm 2 trailing or setpoint mode	<i>R2SP</i> or <i>R2t</i>	<i>R2t</i>	
<b>Functions which follow are accessible only via <i>LR</i> mode</b>				
# <i>drnd</i>	Display Rounding	Value in memory	<i>1</i>	
# <i>dCPt</i>	Decimal point	<i>0.0, 1.0, 0.02, 0.003</i> etc.	<i>Auto</i>	
# <i>FLtr</i>	Digital filter	<i>0</i> to <i>8</i>	<i>3</i>	
<i>Code</i>	Select data type for display	<i>RSC1, URL, di SP, Rfth</i> or <i>PtR</i>	<i>di SP</i>	
<i>R1OPER</i>	Alarm relay 1 operation mode	<i>1 NPt</i> or <i>tout</i>	<i>1 NPt</i>	
^ <i>SCH1</i>	Start of text character 1	Value in memory	<i>-1</i>	
^ <i>SCH2</i>	Start of text character 2	Value in memory	<i>-1</i>	
^ <i>SCH3</i>	Start of text character 3	Value in memory	<i>-1</i>	
^ <i>tchr</i>	Terminating character	<i>-1</i> to <i>255</i>	<i>13</i>	
^ <i>dLAY</i>	No. of characters to skip	<i>0</i> to <i>200</i>	<i>0</i>	
^ <i>bAct</i>	No. of characters back	<i>0</i> to <i>24</i>	<i>0</i>	
^ <i>nchr</i>	No. of characters to skip from <i>SCH1</i>	<i>0</i> to <i>10</i>	<i>0</i>	
^ <i>dPt</i>	Decimal point position of incoming data	<i>-1</i> to <i>8</i>	<i>-1</i>	
^ <i>ALPH</i>	Alpha characters on or off	<i>on</i> or <i>OFF</i>	<i>OFF</i>	
^ <i>POLL1 NPt</i>	Polling	<i>on</i> or <i>OFF</i>	<i>OFF</i>	
^ <i>POLL dLAY</i>	Poll delay	<i>0.0</i> to <i>20.0</i>	<i>1.0</i>	
^ <i>Pch1</i>	1st poll character	<i>-1</i> to <i>255</i>	<i>-1</i>	
^ <i>Pch2</i>	2nd poll character	<i>-1</i> to <i>255</i>	<i>-1</i>	
^ <i>Pch3</i>	3rd poll character	<i>-1</i> to <i>255</i>	<i>-1</i>	
^ <i>Pch4</i>	4th poll character	<i>-1</i> to <i>255</i>	<i>-1</i>	
^ <i>Pch5</i>	5th poll character	<i>-1</i> to <i>255</i>	<i>-1</i>	
^ <i>Pch6</i>	6th poll character	<i>-1</i> to <i>255</i>	<i>-1</i>	
^ <i>Pch7</i>	7th poll character	<i>-1</i> to <i>255</i>	<i>-1</i>	
^ <i>Pch8</i>	8th poll character	<i>-1</i> to <i>255</i>	<i>-1</i>	
<i>dSto</i>	Display timeout secs.	<i>0</i> to <i>9999</i>	<i>10</i>	
<i>tout</i>	Data timeout secs.	<i>0.0</i> to <i>10.0</i>	<i>1.0</i>	

<b>Pbut</b>	<b>P</b> Button function	<i>NONE</i> , <i>H</i> , <i>Lo</i> , <i>H</i> , <i>Lo</i> , <i>EA</i> or <i>ZE</i>	<i>NONE</i>	
<b>FINP</b>	Remote input function	<i>NONE</i> , <i>P</i> , <i>H</i> , <i>d</i> , <i>H</i> , <i>Lo</i> , <i>H</i> , <i>Lo</i> , <i>EA</i> , <i>ZE</i> , <i>SP</i> , <i>Ac</i> , <i>No</i> , <i>Ac</i> or <i>dULL</i>	<i>NONE</i>	
<b>#RACS</b>	Alarm relay access mode	<i>OFF</i> , <i>EASY</i> , <i>NONE</i> or <i>ALL</i>	<i>OFF</i>	
<b>#SPAC</b>	Alarm relay setpoint access	<i>A</i> 1 or <i>A</i> 1-2	<i>A</i> 1	
<b>#CLRZE</b>	Clear zero	<i>CLd</i>	n/a	
<b>baudrate</b>	Baud rate select	<i>300</i> , <i>600</i> , <i>1200</i> , <i>2400</i> , <i>4800</i> , <i>9600</i> , <i>19.2</i> or <i>38.4</i>	<i>9600</i>	
<b>Prty</b>	Parity select	<i>none</i> , <i>EVEN</i> or <i>odd</i>	<i>NONE</i>	
<b>data</b>	Number of data bits	<i>7</i> , <i>b</i> , <i>t</i> or <i>8</i> , <i>b</i> , <i>t</i>	<i>8</i> , <i>b</i> , <i>t</i>	
<b>SER1TYPE</b>	Serial input type	<i>NONE</i> , <i>F232</i> , <i>F485</i> or <i>120</i>	<i>F232</i>	
<b>SER2TYPE</b>	Serial input type	<i>NONE</i> , <i>F232</i> , <i>F485</i> or <i>120</i>	<i>NONE</i>	

**Notes:**

Functions marked # are accessible only when **Code** set to **URL** or **RFth**.

Functions marked ^ are accessible only when **Code** set to **URL**, **ASC** or **RFth**.

See "Function Table - Arithmetic Mode" for a list of the functions available when arithmetic operation is selected i.e. when **Code** set to **RFth**.

## 5.1 ASCII Code Conversion Listing

ASCII for control characters is shown in brackets. e.g. STX is entered as ^B if typing into a communications package for computer communication to the LD. For example <STX>1234<CR> would be typed in as:

^B1234^M

ASCII Char.	Dec	Hex	ASCII Char.	Dec	Hex	ASCII Char.	Dec	Hex
NUL (^@)	000	00	+	43	2B	V	86	56
SOH (^A)	001	01	,	44	2C	W	87	57
STX (^B)	002	02	-	45	2D	X	88	58
ETX (^C)	003	03	.	46	2E	Y	89	59
EOT (^D)	004	04	/	47	2F	Z	90	5A
ENQ (^E)	005	05	0	48	30	[	91	5B
ACK (^F)	006	06	1	49	31	\	92	5C
BEL (^G)	007	07	2	50	32	]	93	5D
BS (^H)	008	08	3	51	33	^	94	5E
HT (^I)	009	09	4	52	34	_	95	5F
LF (^J)	010	0A	5	53	35	`	96	60
VT (^K)	011	0B	6	54	36	a	97	61
FF (^L)	012	0C	7	55	37	b	98	62
CR (^M)	013	0D	8	56	38	c	99	63
SO (^N)	014	0E	9	57	39	d	100	64
SI (^O)	015	0F	:	58	3A	e	101	65
DLE (^P)	016	10	;	59	3B	f	102	66
DC1 (^Q)	017	11	<	60	3C	g	103	67
DC2 (^R)	018	12	=	61	3D	h	104	68
DC3 (^S)	019	13	>	62	3E	i	105	69
DC4 (^T)	020	14	?	63	3F	j	106	6A
NAK (^U)	021	15	@	64	40	k	107	6B
SYN (^V)	022	16	A	65	41	l	108	6C
ETB (^W)	023	17	B	66	42	m	109	6D
CAN (^X)	024	18	C	67	43	n	110	6E
EM (^Y)	025	19	D	68	44	o	111	6F
SUB (^Z)	026	1A	E	69	45	p	112	70
ESC (^[)	027	1B	F	70	46	q	113	71
FS (^\)	028	1C	G	71	47	r	114	72
GS (^_)	029	1D	H	72	48	s	115	73
RS (^)	030	1E	I	73	49	t	116	74
US (^.)	031	1F	J	74	4A	u	117	75
SP (^ )	032	20	K	75	4B	v	118	76
!	033	21	L	76	4C	w	119	77
"	034	22	M	77	4D	x	120	78
#	035	23	N	78	4E	y	121	79
\$	036	24	O	79	4F	z	122	7A
%	037	25	P	80	50	{	123	7B
&	038	26	Q	81	51		124	7C
'	039	27	R	82	52	}	125	7D
(	040	28	S	83	53	~	126	7E
)	041	29	T	84	54	DEL	127	7F
*	042	2A	U	85	55			

## 6 Explanation of Functions - Arithmetic Mode

This second explanation of functions chapter deals with the LD panel meter operation when the **Code** function is set to **Arth**. i.e. when up to eight inputs polled from separate instruments are present via an addressed RS485 connection and these inputs are to be combined via an arithmetic formula. Note the instruments being polled must be from the same manufacturer as the LD.

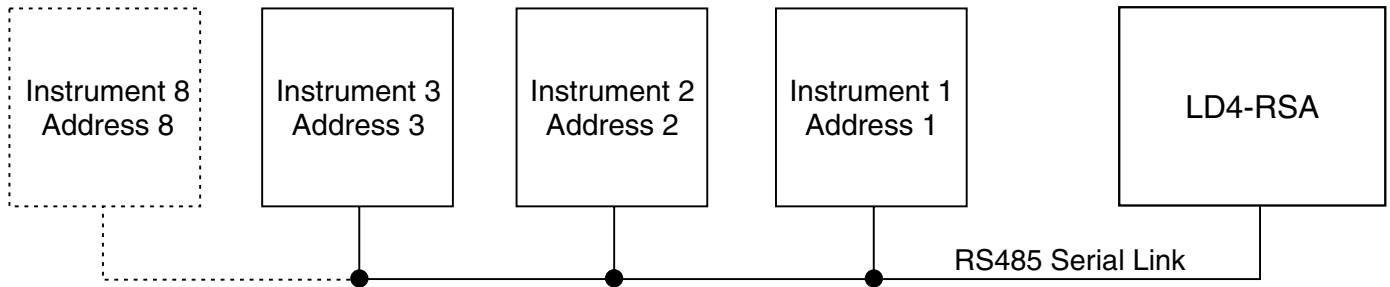



In **Arth** mode the LD will automatically scan the number of input channels selected by the **ArthCh** function (up to 8 channels). These can then be combined by introducing scaling factors to each channel (**BF**, **CF** etc.) and by performing an arithmetic function between channels (**Add**, **Prod** etc.). See the formula under **ERF** function and also refer to the examples at the end of this chapter.

Many **Arth** mode functions are shared with other modes. Functions specific to **Arth** mode are dealt with in this chapter. Refer to Chapter 4 for explanation of the functions common to other modes listed below:

**RILO, RIHI, R2Lo, R2H, RIHY, R2HY, RIno/RInc, R2no/R2nc, R2SP/R2st, drnd, dCPE, FLtr, bAudFRe, Prty, dRtR, code, R1OPEF, dSto, tout, Pbut, FIAP, ACCS, SPAC, CLF ZEF0, bAudFRe, Prty, dRtR, SEF1 TYPE and SEF2 TYPE.**

The following functions will only be seen when the **code** function is set to **Arth**.

Function	Description
<b>ArthCh</b>	<p>Number of channels (1 to 8)</p> <p>Displays and selects the number of input channels used. Select between 1 and 8 channels. The LD will automatically poll the number of channels selected. Each input channel must be set to a different address. Addresses which can be used are 1 to 8. e.g. if only 2 channels are used then these must be given addresses 1 and 2. The addresses are set within the instrument being polled, not in the LD. The addresses referred to in the LD instructions relates to the information required from each input channel and the address of that channel.</p> <p>The following display messages are not shown for unused channels. e.g. the <b>Ch3Addr</b> function will not be seen if only 2 channels are selected.</p>
<b>Ch1Addr</b>	<p>Data required from channel 1 input.</p> <p>This function determines what information is requested for the channel 1 input. It also determines which address the information is taken from.</p> <p>Choices are <b>P1, P2, P3, P4, S1, S2, S3, S4, P5, S5, P6, S6, P7, S7, P8</b> or <b>S8</b>. The letters <b>P</b> and <b>S</b> refer to the primary (<b>P</b>) or secondary (<b>S</b>) display values from the transmitting instrument e.g. the primary display value of a pH instrument will be the pH value on the display whilst the secondary display value would be the solution temperature. The number refers to the address of the instrument. For example if <b>Ch1Addr</b> function has <b>P3</b> selected then the primary display value from the instrument with address 3 will be requested as the channel 1 input for the LD. This value will then be placed in the formula below as the <b>Ch1</b> value.</p>
<b>Ch2Addr to Ch8Addr</b>	<p>Data required from channel 2 to 8 inputs.</p> <p>This function determines what information (primary or secondary) is requested for the channel 2 to 8 inputs i.e. the <b>Ch2 to Ch8</b> value to be input to the formula. Other details are as per <b>Ch1Addr</b> function.</p>

<b>Ch 1 dCpt</b>	<p>Channel 1 decimal point.          Displays and sets the decimal point for input channel 1. By pressing the  or  pushbuttons the decimal point position may be set. The display will indicate as follows: <b>0</b> (no decimal point), <b>0. 1</b> (1 decimal place), <b>0.02</b> (2 decimal places), <b>0.003</b> (3 decimal places) etc.</p>																								
<b>Ch 2 dCpt to Ch 8 dCpt</b>	<p>Channel 2 to channel 8 decimal point.          Displays and sets the decimal point for input channels 2 to 8 (see <b>Ch 1 dCpt</b> above).</p>																								
<b>EA 1, Eb 1 etc.</b>	<p>Arithmetical values.          The LD may be set up to perform a variety of mathematical functions according the equation:</p> $\frac{A1 \times (Ch1 + b1)}{C1} \left\{ \begin{array}{l} \text{add} \\ \text{sub} \\ \text{prod} \\ \text{div} \\ \text{high} \\ \text{low} \\ \text{sine} \\ \text{cos} \\ \text{c.sub} \end{array} \right\} \frac{A2 \times (Ch2 + b2)}{C2} \left\{ \begin{array}{l} \text{add} \\ \text{sub} \\ \text{prod} \\ \text{div} \\ \text{high} \\ \text{low} \\ \text{sine} \\ \text{cos} \\ \text{c.sub} \end{array} \right\} \frac{A3 \times (Ch3 + b3)}{C3} \left\{ \begin{array}{l} \text{add} \\ \text{sub} \\ \text{prod} \\ \text{div} \\ \text{high} \\ \text{low} \\ \text{sine} \\ \text{cos} \\ \text{c.sub} \end{array} \right\} \frac{A4 \times (Ch4 + b4)}{C4}$ <p>etc. for channels 5, 6, 7 &amp; 8.</p> <p>The A, b &amp; C value for each channel may be individually entered (note: A &amp; C are whole numbers, b has the same decimal place as its associated channel). The display for each parameter is as follows:</p> <table border="0" data-bbox="327 1160 1460 1272"> <tr> <td><b>EA 1</b></td> <td><b>EA 2</b></td> <td><b>EA 3</b></td> <td><b>EA 4</b></td> <td><b>EA 5</b></td> <td><b>EA 6</b></td> <td><b>EA 7</b></td> <td><b>EA 8</b></td> </tr> <tr> <td><b>Eb 1</b></td> <td><b>Eb 2</b></td> <td><b>Eb 3</b></td> <td><b>Eb 4</b></td> <td><b>Eb 5</b></td> <td><b>Eb 6</b></td> <td><b>Eb 7</b></td> <td><b>Eb 8</b></td> </tr> <tr> <td><b>EC 1</b></td> <td><b>EC 2</b></td> <td><b>EC 3</b></td> <td><b>EC 4</b></td> <td><b>EC 5</b></td> <td><b>EC 6</b></td> <td><b>EC 7</b></td> <td><b>EC 8</b></td> </tr> </table> <p>The operation of each channel may be set up as follows:</p>	<b>EA 1</b>	<b>EA 2</b>	<b>EA 3</b>	<b>EA 4</b>	<b>EA 5</b>	<b>EA 6</b>	<b>EA 7</b>	<b>EA 8</b>	<b>Eb 1</b>	<b>Eb 2</b>	<b>Eb 3</b>	<b>Eb 4</b>	<b>Eb 5</b>	<b>Eb 6</b>	<b>Eb 7</b>	<b>Eb 8</b>	<b>EC 1</b>	<b>EC 2</b>	<b>EC 3</b>	<b>EC 4</b>	<b>EC 5</b>	<b>EC 6</b>	<b>EC 7</b>	<b>EC 8</b>
<b>EA 1</b>	<b>EA 2</b>	<b>EA 3</b>	<b>EA 4</b>	<b>EA 5</b>	<b>EA 6</b>	<b>EA 7</b>	<b>EA 8</b>																		
<b>Eb 1</b>	<b>Eb 2</b>	<b>Eb 3</b>	<b>Eb 4</b>	<b>Eb 5</b>	<b>Eb 6</b>	<b>Eb 7</b>	<b>Eb 8</b>																		
<b>EC 1</b>	<b>EC 2</b>	<b>EC 3</b>	<b>EC 4</b>	<b>EC 5</b>	<b>EC 6</b>	<b>EC 7</b>	<b>EC 8</b>																		
<b>OP 1</b>	<p>Channel 1 and channel 2 arithmetic operation type [result of channel 1 and 2].</p> <table border="0" data-bbox="475 1355 1452 1713"> <tr> <td><b>Add</b></td> <td>channel 1 plus channel 2</td> </tr> <tr> <td><b>Sub</b></td> <td>channel 1 minus channel 2</td> </tr> <tr> <td><b>Prod</b></td> <td>channel 1 times channel 2</td> </tr> <tr> <td><b>Div</b></td> <td>channel 1 divided by channel 2</td> </tr> <tr> <td><b>H, 9h</b></td> <td>highest of channel 1 or 2</td> </tr> <tr> <td><b>Lo</b></td> <td>lowest of channel 1 or 2</td> </tr> <tr> <td><b>SINE</b></td> <td>channel 1 times the sine of the angle displayed at channel 2</td> </tr> <tr> <td><b>COS</b></td> <td>channel 1 times the cosine of the angle displayed at channel 2</td> </tr> <tr> <td><b>C.SUB</b></td> <td>channel 1 clock input minus channel 2 clock input</td> </tr> </table> <p>Note the <b>C.SUB</b> function is meant for time inputs from clocks only.</p>	<b>Add</b>	channel 1 plus channel 2	<b>Sub</b>	channel 1 minus channel 2	<b>Prod</b>	channel 1 times channel 2	<b>Div</b>	channel 1 divided by channel 2	<b>H, 9h</b>	highest of channel 1 or 2	<b>Lo</b>	lowest of channel 1 or 2	<b>SINE</b>	channel 1 times the sine of the angle displayed at channel 2	<b>COS</b>	channel 1 times the cosine of the angle displayed at channel 2	<b>C.SUB</b>	channel 1 clock input minus channel 2 clock input						
<b>Add</b>	channel 1 plus channel 2																								
<b>Sub</b>	channel 1 minus channel 2																								
<b>Prod</b>	channel 1 times channel 2																								
<b>Div</b>	channel 1 divided by channel 2																								
<b>H, 9h</b>	highest of channel 1 or 2																								
<b>Lo</b>	lowest of channel 1 or 2																								
<b>SINE</b>	channel 1 times the sine of the angle displayed at channel 2																								
<b>COS</b>	channel 1 times the cosine of the angle displayed at channel 2																								
<b>C.SUB</b>	channel 1 clock input minus channel 2 clock input																								

<b>OP2</b>	<p>Operation type 2 ([result of channel 1 and 2] and channel 3)</p> <p><b>Add</b> result of (Ch1 <b>OP1</b> Ch2) plus Ch3</p> <p><b>Sub</b> result of (Ch1 <b>OP1</b> Ch2) minus Ch3</p> <p><b>Prod</b> result of (Ch1 <b>OP1</b> Ch2) times Ch3</p> <p><b>div</b> result of (Ch1 <b>OP1</b> Ch2) divided by Ch3</p> <p><b>Hgh</b> highest of result of (Ch1 <b>OP1</b> Ch2) or 3</p> <p><b>Lo</b> lowest of result of (Ch1 <b>OP1</b> Ch2) or 3</p> <p><b>SINE</b> result of (Ch1 <b>OP1</b> Ch2) times the sine of the angle displayed at channel 3</p> <p><b>COS</b> result of (Ch1 <b>OP1</b> Ch2) times the cosine of the angle displayed at channel 3</p> <p><b>CSub</b> channel 1 clock input minus channel 2 clock input</p>
<b>OP3</b>	<p>Channel 1, 2, 3 &amp; 4 operation type (([result of channel 1 and 2] and channel 3) and channel 4)</p> <p><b>Add</b> result of (Ch1 <b>OP1</b> Ch2 <b>OP2</b> Ch3) plus Ch4</p> <p><b>Sub</b> result of (Ch1 <b>OP1</b> Ch2 <b>OP2</b> Ch3) minus Ch4</p> <p><b>Prod</b> result of (Ch1 <b>OP1</b> Ch2 <b>OP2</b> Ch3) times Ch4</p> <p><b>div</b> result of (Ch1 <b>OP1</b> Ch2 <b>OP2</b> Ch3) divided by Ch4</p> <p><b>Hgh</b> highest of result of (Ch1 <b>OP1</b> Ch2 <b>OP2</b> Ch3) or 4</p> <p><b>Lo</b> lowest of result of (Ch1 <b>OP1</b> Ch2 <b>OP2</b> Ch3) or 4</p> <p><b>SINE</b> result of (Ch1 <b>OP1</b> Ch2 <b>OP2</b> Ch3) times the sine of the angle displayed at channel 4</p> <p><b>COS</b> result of (Ch1 <b>OP1</b> Ch2 <b>OP2</b> Ch3) times the cosine of the angle displayed at channel 4</p> <p><b>CSub</b> channel 1 clock input minus channel 2 clock input</p>
<b>OP4 to OP7</b>	Operation types 4, 5, 6 & 7. See <b>OP1</b> , <b>OP2</b> and <b>OP3</b> for description
<b>Ch1</b>	<p>Display polarity - channel 1 (<b>BOTH</b>, <b>POS</b>, <b>NEG</b> or <b>ABS</b>).</p> <p>Displays and sets the polarity selection for the display of the engineering value for channel 1. If set to <b>BOTH</b> then the display will indicate both positive and negative values. If set to <b>POS</b> the display will allow only positive values with any values below zero being rounded to zero. If set to <b>NEG</b> then the display will allow only negative values with any value above zero being rounded to zero. If set to <b>ABS</b> then the absolute value will be displayed i.e. negative numbers will be displayed as positive numbers.</p>
<b>Ch2 to Ch8</b>	Display polarity - channels 2 to 8. See <b>Ch1</b> above for description.

### Returning to the normal measure mode

When the calibration procedure has been completed it is advisable to return the instrument to the normal mode (where calibration functions cannot be tampered with). To return to the normal mode, turn off power to the instrument, wait a few seconds and then restore power.

## 6.1 Examples

The following examples may be used as a guide for setting up your instrument.

### Example 1:

To get an average of channels 1, 2, 3 and 4 each input is added together and divided by 4:

$$\left( \frac{Ch1}{4} + \frac{Ch2}{4} + \frac{Ch3}{4} + \frac{Ch4}{4} \right)$$

Program

```

ER1 = 1, Eb1 = 0, EC1 = 4,
ER2 = 1, Eb2 = 0, EC2 = 4,
ER3 = 1, Eb3 = 0, EC3 = 4,
ER4 = 1, Eb4 = 0, EC4 = 4,
OP1 = Add
OP2 = Add
OP3 = Add
    
```

$$\frac{1 \times (Ch1+0)}{4} \text{ Add } \frac{1 \times (Ch2+0)}{4} \text{ Add } \frac{1 \times (Ch3+0)}{4} \text{ Add } \frac{1 \times (Ch4+0)}{4}$$

**Example 2:** Three inputs are present. The display is to indicate the highest of the 3 inputs. Channel 1 input is to be multiplied 2/3.

Program

```

ER1 = 2, Eb1 = 0, EC1 = 3,
ER2 = 1, Eb2 = 0, EC2 = 1,
ER3 = 1, Eb3 = 0, EC3 = 1,
OP1 = H, 9H
OP2 = H, 9H
    
```

$$\frac{2 \times (Ch1+0)}{3} \text{ HIGH } \frac{1 \times (Ch2+0)}{1} \text{ HIGH } \frac{1 \times (Ch3+0)}{1}$$

**Example 3:** To multiply the figure displayed on channel 1 by the sine of the angle of the figure displayed on channel 2. The second channel would normally be scaled from 0 to 360 when either the sine or cosine is being used, however numbers outside this range are acceptable.

Program:

```

ER1 = 1, Eb1 = 0, EC1 = 1,
ER2 = 1, Eb2 = 0, EC2 = 1,
OP1 = S, PE.
    
```

$$\frac{1 \times (Ch1+0)}{1} \text{ SINE } \frac{1 \times (Ch2+0)}{1}$$

## 7 Function Table - Arithmetic Mode

Initial display	Meaning of display	Next display	Default settings	Record Your Settings
<b>A 1Lo</b>	Alarm 1 low setpoint value	Setpoint value or <b>OFF</b>	<b>OFF</b>	
<b>A 1Hi</b>	Alarm 1 high setpoint value	Setpoint value or <b>OFF</b>	<b>1000</b>	
<b>A2Lo</b>	Alarm 2 low setpoint value	Setpoint value or <b>OFF</b>	<b>OFF</b>	
<b>A2Hi</b>	Alarm 2 high setpoint value	Setpoint value or <b>OFF</b>	<b>1000</b>	
<b>A 1HY</b>	Alarm 1 hysteresis	Hysteresis value in measured units	<b>1</b>	
<b>A2HY</b>	Alarm 2 hysteresis	Hysteresis value in measured units	<b>1</b>	
<b>A 1tt</b>	Alarm 1 trip time	No of seconds before relay 1 trips	<b>0</b>	
<b>A2tt</b>	Alarm 2 trip time	No of seconds before relay 2 trips	<b>0</b>	
<b>A 1rt</b>	Alarm 1 reset time	No of seconds before relay 1 resets	<b>0</b>	
<b>A2rt</b>	Alarm 2 reset time	No of seconds before relay 2 resets	<b>0</b>	
<b>A 1no</b> or <b>A 1nc</b>	Alarm 1 action N/O or N/C	<b>A 1no</b> or <b>A 1nc</b>	<b>A 1no</b>	
<b>A2no</b> or <b>A2nc</b>	Alarm 2 action N/O or N/C	<b>A2no</b> or <b>A2nc</b>	<b>A2no</b>	
<b>A2SP</b> or <b>A2ti</b>	Alarm 2 trailing or setpoint mode	<b>A2SP</b> or <b>A2ti</b>	<b>A2ti</b>	
Functions below are accessible only via <b>CR</b> L mode				
<b>rEC-</b>	Retransmission low level. Seen only if option fitted.	Value in memory	<b>0</b>	
<b>rEC+</b>	Recorder output high limit. Seen only if option fitted.	Value in memory	<b>1000</b>	
<b>drnd</b>	Display rounding	Value in memory	<b>1</b>	
<b>dCPt</b>	Display decimal point	Decimal point (i.e. <b>0.1</b> or <b>0.02</b> etc.)	<b>0</b>	
<b>FLtr</b>	Digital filter	<b>0</b> to <b>8</b> ( <b>8</b> =max filtering)	<b>2</b>	
<b>Arth CH</b>	Number of channels	<b>1, 2, 3</b> or <b>4</b>	<b>4</b>	
<b>Ch 1 Addr</b>	Channel 1 address	<b>P 1</b> to <b>P 8</b> or <b>S 1</b> to <b>S 8</b>	<b>P 1</b>	
<b>Ch 2 Addr</b>	Channel 2 address	<b>P 1</b> to <b>P 8</b> or <b>S 1</b> to <b>S 8</b>	<b>P 2</b>	
<b>Ch 3 Addr</b>	Channel 3 address	<b>P 1</b> to <b>P 8</b> or <b>S 1</b> to <b>S 8</b>	<b>P 3</b>	
<b>Ch 4 Addr</b>	Channel 4 address	<b>P 1</b> to <b>P 8</b> or <b>S 1</b> to <b>S 8</b>	<b>P 4</b>	
<b>Ch 5 Addr</b>	Channel 5 address	<b>P 1</b> to <b>P 8</b> or <b>S 1</b> to <b>S 8</b>	<b>P 5</b>	
<b>Ch 6 Addr</b>	Channel 6 address	<b>P 1</b> to <b>P 8</b> or <b>S 1</b> to <b>S 8</b>	<b>P 6</b>	
<b>Ch 7 Addr</b>	Channel 7 address	<b>P 1</b> to <b>P 8</b> or <b>S 1</b> to <b>S 8</b>	<b>P 7</b>	
<b>Ch 8 Addr</b>	Channel 8 address	<b>P 1</b> to <b>P 8</b> or <b>S 1</b> to <b>S 8</b>	<b>P 8</b>	
<b>Ch 1 dCPt</b>	Channel 1 decimal point	Decimal point (e.g. <b>0.1</b> or <b>0.02</b> etc.)	<b>0</b>	
<b>Ch 2 dCPt</b>	Channel 2 decimal point	Decimal point (e.g. <b>0.1</b> or <b>0.02</b> etc.)	<b>0</b>	
<b>Ch 3 dCPt</b>	Channel 3 decimal point	Decimal point (e.g. <b>0.1</b> or <b>0.02</b> etc.)	<b>0</b>	
<b>Ch 4 dCPt</b>	Channel 4 decimal point	Decimal point (e.g. <b>0.1</b> or <b>0.02</b> etc.)	<b>0</b>	
<b>Ch 5 dCPt</b>	Channel 5 decimal point	Decimal point (e.g. <b>0.1</b> or <b>0.02</b> etc.)	<b>0</b>	
<b>Ch 6 dCPt</b>	Channel 6 decimal point	Decimal point (e.g. <b>0.1</b> or <b>0.02</b> etc.)	<b>0</b>	
<b>Ch 7 dCPt</b>	Channel 7 decimal point	Decimal point (e.g. <b>0.1</b> or <b>0.02</b> etc.)	<b>0</b>	
<b>Ch 8 dCPt</b>	Channel 8 decimal point	Decimal point (e.g. <b>0.1</b> or <b>0.02</b> etc.)	<b>0</b>	
<b>EA 1</b>	Channel 1 A function	Value in memory	<b>1</b>	
<b>EB 1</b>	Channel 1 b function	Value in memory	<b>0</b>	
<b>EC 1</b>	Channel 1 C function	Value in memory	<b>1</b>	
<b>EA 2</b>	Channel 2 A function	Value in memory	<b>1</b>	
<b>EB 2</b>	Channel 2 b function	Value in memory	<b>0</b>	
<b>EC 2</b>	Channel 2 C function	Value in memory	<b>1</b>	
<b>EA 3</b>	Channel 3 A function	Value in memory	<b>1</b>	
<b>EB 3</b>	Channel 3 b function	Value in memory	<b>0</b>	
<b>EC 3</b>	Channel 3 C function	Value in memory	<b>1</b>	
<b>EA 4</b>	Channel 4 A function	Value in memory	<b>1</b>	
<b>EB 4</b>	Channel 4 b function	Value in memory	<b>0</b>	

<b>EC4</b>	Channel 4 C function	Value in memory	<b>1</b>	
<b>EA5</b>	Channel 5 A function	Value in memory	<b>1</b>	
<b>Eb5</b>	Channel 5 b function	Value in memory	<b>0</b>	
<b>EC5</b>	Channel 5 C function	Value in memory	<b>1</b>	
<b>EA6</b>	Channel 6 A function	Value in memory	<b>1</b>	
<b>Eb6</b>	Channel 6 b function	Value in memory	<b>0</b>	
<b>EC6</b>	Channel 7 C function	Value in memory	<b>1</b>	
<b>EA7</b>	Channel 7 A function	Value in memory	<b>1</b>	
<b>Eb7</b>	Channel 7 b function	Value in memory	<b>0</b>	
<b>EC7</b>	Channel 7 C function	Value in memory	<b>1</b>	
<b>EA8</b>	Channel 8 A function	Value in memory	<b>1</b>	
<b>Eb8</b>	Channel 8 b function	Value in memory	<b>0</b>	
<b>EC8</b>	Channel 8 C function	Value in memory	<b>1</b>	
<b>OP 1</b>	Operation 1	<b>Add.Sub.Prod.d. u.H. 9h.Lo SI NE COS or CSUb</b>	<b>Add</b>	
<b>OP 2</b>	Operation 2	<b>Add.Sub.Prod.d. u.H. 9h.Lo SI NE COS or CSUb</b>	<b>Add</b>	
<b>OP 3</b>	Operation 3	<b>Add.Sub.Prod.d. u.H. 9h.Lo SI NE COS or CSUb</b>	<b>Add</b>	
<b>OP 4</b>	Operation 4	<b>Add.Sub.Prod.d. u.H. 9h.Lo SI NE COS or CSUb</b>	<b>Add</b>	
<b>OP 5</b>	Operation 5	<b>Add.Sub.Prod.d. u.H. 9h.Lo SI NE COS or CSUb</b>	<b>Add</b>	
<b>OP 6</b>	Operation 6	<b>Add.Sub.Prod.d. u.H. 9h.Lo SI NE COS or CSUb</b>	<b>Add</b>	
<b>OP 7</b>	Operation 7	<b>Add.Sub.Prod.d. u.H. 9h.Lo SI NE COS or CSUb</b>	<b>Add</b>	
<b>Ch 1</b>	Display polarity, channel 1	<b>bOeH, POS.NE9 or Ab5</b>	<b>both</b>	
<b>Ch 2</b>	Display polarity, channel 2	<b>bOeH, POS.NE9 or Ab5</b>	<b>both</b>	
<b>Ch 3</b>	Display polarity, channel 3	<b>bOeH, POS.NE9 or Ab5</b>	<b>both</b>	
<b>Ch 4</b>	Display polarity, channel 4	<b>bOeH, POS.NE9 or Ab5</b>	<b>both</b>	
<b>Ch 5</b>	Display polarity, channel 5	<b>bOeH, POS.NE9 or Ab5</b>	<b>both</b>	
<b>Ch 6</b>	Display polarity, channel 6	<b>bOeH, POS.NE9 or Ab5</b>	<b>both</b>	
<b>Ch 7</b>	Display polarity, channel 7	<b>bOeH, POS.NE9 or Ab5</b>	<b>both</b>	
<b>Ch 8</b>	Display polarity, channel 8	<b>bOeH, POS.NE9 or Ab5</b>	<b>both</b>	
<b>Code</b>	Select data type for display	<b>d: SP.ASCI .UAl .ARtH or PtR</b>	<b>d: SP</b>	
<b>Al OPEr</b>	Alarm relay 1 operation mode	<b>1 nPt or tOut</b>	<b>1 nPt</b>	
<b>dS.tO</b>	Display time out (seconds)	Value in memory	<b>10.0</b>	
<b>tOut</b>	Time out (seconds)	Value in memory	<b>1.0</b>	
<b>Pbut</b>	<b>P</b> button function	<b>NONE .H. .Lo.H. Lo.tARtE or ZEFO</b>	<b>NONE</b>	
<b>r: nP</b>	Remote input function	<b>NONE .P.HLd.d.HLd. H. .Lo.H. Lo.tARtE.ZEFO.SPAC. NoRc or duLL</b>	<b>NONE</b>	
<b>ACC5</b>	Alarm relay access mode	<b>OFF.EASy or NONE</b>	<b>OFF</b>	
<b>SPAC</b>	Setpoint access	<b>R 1 or R 1-2</b>	<b>R 1</b>	
<b>CLr ZEFO</b>	Clear Zero	<b>CLrd</b>	n/a	
<b>BAUD rARtE</b>	Baud rate select	<b>50.75. 150.300.600. 1200. 2400.4800.9600 or 19.2</b>	<b>9600</b>	
<b>PrtY</b>	Parity select	<b>NONE.EVEN or odd</b>	<b>NONE</b>	
<b>dARtR</b>	Data type	<b>8b, t or 7b, t</b>	<b>8b, t</b>	
<b>SEr. tEtPE</b>	Serial input type	<b>r232 or r485</b>	<b>r232</b>	
<b>SEr.2EtPE</b>	Serial input type	<b>NONE .r232.r485 or: 20</b>	<b>NONE</b>	

## 8 Display Character Set

Some alphabetic characters cannot be displayed in seven segment format, listed below are the input character and the resultant display. If an alphabetic character is received which can be displayed on the seven segment display it is displayed, and the input is advanced by one. If the character is not displayable (e.g. W), then the character is ignored. See the "Function table" chapter for a full ASCII conversion chart.

ASC11 Character	Dec	Hex	Digital Display	ASC11 Character	Dec	Hex	Digital Display
SPACE	032	20		U	085	55	U
-	045	21	-	V	086	56	V
.	046	22	.	W	NOT DISPLAYABLE		
0	048	30	0	X	NOT DISPLAYABLE		
1	049	31	1	Y	089	59	Y
2	050	32	2	Z	090	5A	Z
3	051	33	3	a	097	61	A
4	052	34	4	b	098	62	B
5	053	35	5	c	099	63	C
6	054	36	6	d	100	64	D
7	055	37	7	e	101	65	E
8	056	38	8	f	102	66	F
9	057	39	9	g	103	67	G
A	065	41	A	h	104	68	H
B	066	42	B	i	105	69	I
C	067	43	C	j	106	6A	J
D	068	44	D	k	NOT DISPLAYABLE		
E	069	45	E	l	108	6C	L
F	070	46	F	m	NOT DISPLAYABLE		
G	071	47	G	n	110	6E	N
H	072	48	H	o	111	6F	O
I	073	49	I	p	112	70	P
J	074	4A	J	q	113	71	Q
K	NOT DISPLAYABLE			r	114	72	R
L	076	4C	L	s	115	73	S
M	NOT DISPLAYABLE			t	116	74	T
N	078	4E	N	u	117	75	U
O	079	4F	O	v	118	76	V
P	080	50	P	w	NOT DISPLAYABLE		
Q	081	51	Q	x	NOT DISPLAYABLE		
R	082	52	R	y	121	79	Y
S	083	53	S	z	122	7A	Z
T	084	54	T				

---

## 9 Specifications

---

### 9.1 Technical Specifications

Display:	4 or 6 digit 39mm yellow electromagnetic type
Input types:	Either RS232, RS485 or Serial current loop (input type is factory configured)
Baud rate:	300, 600, 1200, 2400, 4800, 9600, 19.2 or 38.4 Programmable
Microprocessor:	MC68HC11 CMOS
Ambient Temperature:	-10 to 60°C, non condensing
Power Supply:	AC 240V, 110V 50/60Hz or DC 12 to 24V non isolated Supply type is factory configured
Outputs:	2 x Setpoint relays, form A, rated 5A at 240VAC
Power Consumption:	AC supply 15 VA max, DC supply typically less than 10VA, 3A peak
DC Supply output:	5VDC or unregulated 14VDC (link selectable) (25mA max.)

### 9.2 Physical Characteristics

Case size (mm):	255 x 145 x 125
Weight:	1.3 kg
Mounting hole locations (mm):	180(w) x 155(h)

---

## 10 Guarantee and Service

---

The product supplied with this manual is guaranteed against faulty workmanship for a period of 2 years from the date of dispatch.

Our obligation assumed under this guarantee is limited to the replacement of parts which, by our examination, are proved to be defective and have not been misused, carelessly handled, defaced or damaged due to incorrect installation. This guarantee is VOID where the unit has been opened, tampered with or if repairs have been made or attempted by anyone except an authorised representative of the manufacturing company.

Products for attention under guarantee (unless otherwise agreed) **must be returned to the manufacturer freight paid** and, if accepted for free repair, will be returned to the customers address in Australia free of charge.

When returning the product for service or repair a full description of the fault and the mode of operation used when the product failed must be given.

In any event the manufacturer has no other obligation or liability beyond replacement or repair of this product.

Modifications may be made to any existing or future models of the unit as it may deem necessary without incurring any obligation to incorporate such modifications in units previously sold or to which this guarantee may relate.

This document is the property of  
the instrument manufacturer  
and may not be reproduced in whole or part without the  
written consent of the manufacturer.

This product is designed and manufactured in Australia.

