

**LD-BC**  
Binary/BCD/Gray Code  
Large Digit Display  
Operation and Instruction Manual

---

**AMALGAMATED INSTRUMENT CO PTY LTD**

ACN: 001 589 439

Unit 5, 28 Leighton Place Hornsby  
NSW 2077 AUSTRALIA

Telephone: +61 2 9476 2244  
Facsimile: +61 2 9476 2902

e-mail: [sales@aicpl.com.au](mailto:sales@aicpl.com.au)  
Internet: [www.aicpl.com.au](http://www.aicpl.com.au)

---

# Table of Contents

---

<b>Introduction</b> . . . . .	<b>3</b>
Meter setup . . . . .	4
<b>Mechanical Installation</b> . . . . .	<b>5</b>
<b>Electrical installation</b> . . . . .	<b>6</b>
Power supply connections . . . . .	7
Input wiring examples . . . . .	9
Optional relay connections . . . . .	9
Optional serial communications connections . . . . .	9
Data input connections . . . . .	10
Remote decimal point selection and display hold . . . . .	16
<b>Explanation of functions</b> . . . . .	<b>17</b>
<b>Function table</b> . . . . .	<b>22</b>
<b>Scaled inputs.</b> . . . . .	<b>24</b>
<b>Weighted digital input operation &amp; electrical connections</b> . . . . .	<b>26</b>
<b>RS232/RS485 Commands</b> . . . . .	<b>28</b>
<b>Specifications</b> . . . . .	<b>33</b>
Technical Specifications . . . . .	33
Options . . . . .	33
Physical Characteristics . . . . .	33
<b>Guarantee and service</b> . . . . .	<b>34</b>

---

# 1 Introduction

---

This manual contains information for the installation and operation of the LD-BC Monitor. The LD is available with up to 6 digit displays and may be configured to accept inputs of BCD, binary, Gray code or special modes allowing either scaled or weighted displays. The inputs may be presented in parallel, strobed or addressed form. Sixteen input lines are available. For BCD inputs, addressed, strobed or up to 4 digit parallel four of these input lines can be allocated for use as remote decimal point or display hold.

Power supply versions for 100 & 200mm displays available are AC 240V/110V 50/60Hz multi tap user selectable or AC 24/32/42/48 V 50/60Hz multi tap user selectable or DC 12 to 48V isolated or DC 24V non isolated. Power supply versions for the 57mm 4 digit display are 240V, 110V, 12 to 48VDC isolated or 24VDC non isolated. Power supply types are factory configured.

Optional relays & serial communications may also be provided.

Unless otherwise specified at the time of order, your LD has been factory set to a standard configuration. Like all other LD series instruments the configuration and calibration is easily changed by the user. Initial changes may require altering PCB links, other changes are made by push button functions.

The LD series of Large Digit Displays are designed for high reliability in industrial applications. The high brightness LED display provides good visibility, even in areas with high ambient light levels. An automatic display brightness facility is available on LED display models which, when enabled, allows the display brightness to be automatically adjusted to suit ambient light conditions.

## 1.1 Meter setup

The LD setup and calibration functions are configured through a push button sequence. Two levels of access are provided for setting up and calibrating:-

**FUNC** mode (simple push button sequence) allows access to commonly set up functions such as alarm setpoints. **CAL** mode (power up sequence plus push button sequence) allows access to all functions including calibration parameters. One of the setup functions named **ACCESS** can be used to control access to functions e.g. if the **ACCESS** function is set to **ALL** then all functions will be accessible via **FUNC** mode.

The three push buttons are located on the main circuit board, the front cover will need to be removed to gain access to the pushbuttons. Once **CAL** or **FUNC** mode has been entered you can step through the functions by pressing and releasing the **F** push button until the required function is reached. Changes to functions are made by pressing the **▲** or **▼** push button (in some cases both simultaneously) when the required function is reached. Changes to function settings will not be accepted and stored in memory until the **F** button is pressed to accept the change.

### Entering **CAL** Mode

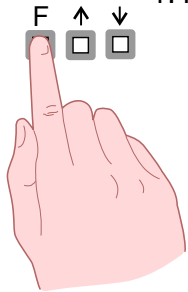

1. Remove power from the instrument and wait 5 seconds. Hold in the **F** button and reapply power. The display will indicate **CAL** as part of the "wake up messages" when the **CAL** message is seen you can release the button.  
Move to step 2 below.

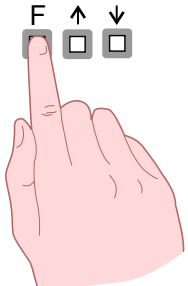

2. When the "wake up" messages have finished and the display has settled down to its normal reading press, then release the **F** button.  
Move to step 3 below.

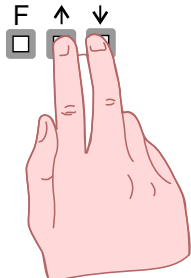

3. Within 2 seconds of releasing the **F** button press, then release the **▲** and **▼** buttons together. The display will now indicate **FUNC** followed by the first function.

Notes: If step 1 above has been completed then the instrument will remain in this **CAL** mode state until power is removed. i.e. there is no need to repeat step 1 when accessing function unless power has been removed.

The instrument should show all 8's on power up e.g. **8888** if the instrument does not reset then these numbers will not be seen. Switch off the instrument and allow a longer time delay before powering up again.

### Entering **FUNC** Mode

No special power up procedure is required to enter **FUNC** mode.

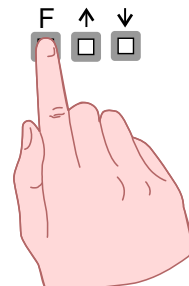

1. When the "wake up" messages have finished and the display has settled down to its normal reading press, then release the **F** button.  
Move to step 2 below.

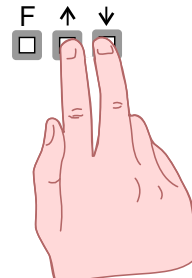

2. Within 2 seconds of releasing the **F** button press, then release the **▲** and **▼** buttons together. The display will now indicate **FUNC** followed by the first function.

## 2 Mechanical Installation

### 100mm 4 digit LED or Electromagnetic

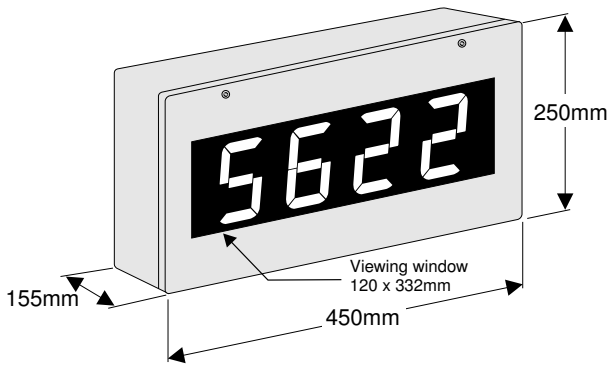

### 100mm 5 digit Electromagnetic only

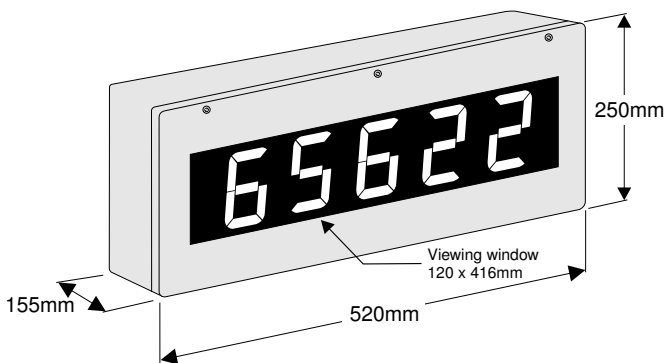

### 100mm 6 digit LED or Electromagnetic

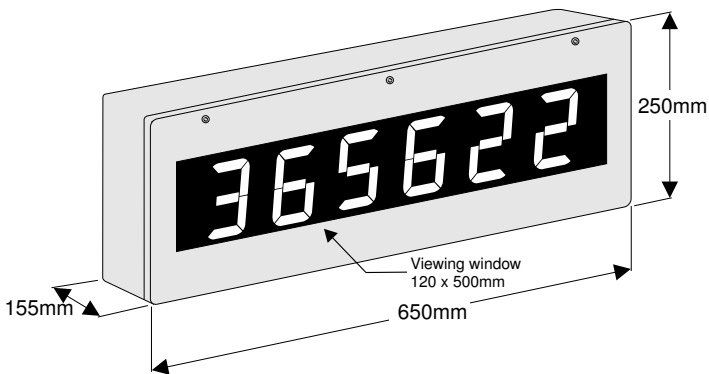

### 200mm 4 digit LED

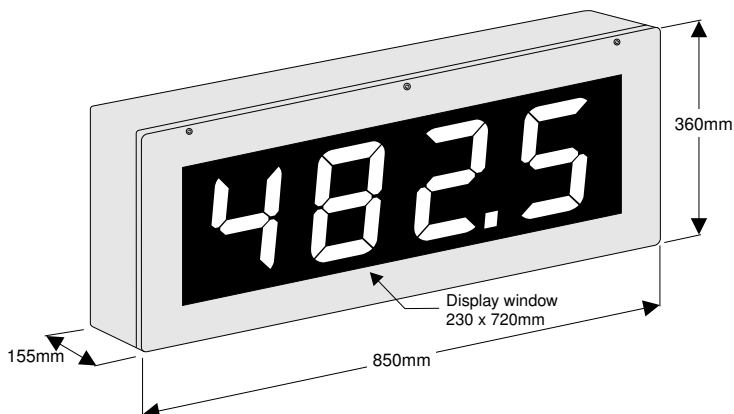

### 57mm 4 digit LED

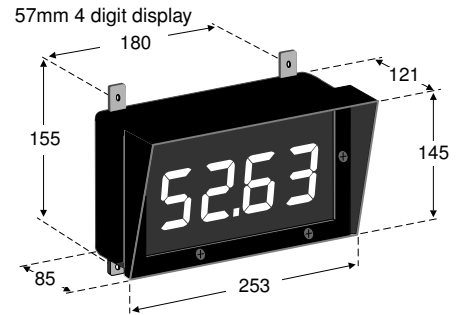

An optional panel mount kit is available for the 57mm 4 digit display. Panel cut out size is 240 x 130mm

Four mounting kit brackets are supplied for use with all 100mm & 200mm display models.

Diagrams below illustrate vertical and horizontal installation. If mounting without the brackets is preferred then the 9mm dia. case holes provided for the brackets can be used as alternative mounting holes. If the brackets are not used in mounting these holes should be sealed against dust and water.

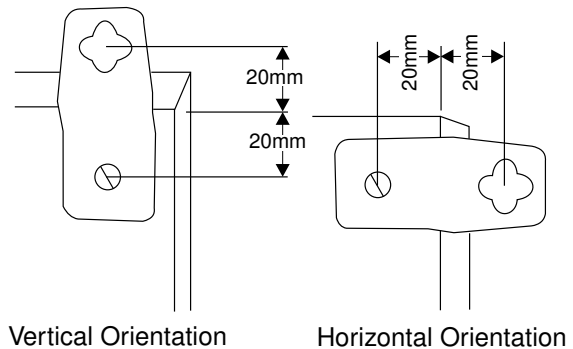

### 3 Electrical installation

The LD Panel Meter is designed for continuous operation and no power switch is fitted to the unit. It is recommended that an external switch and fuse be provided to allow the unit to be removed for servicing.

The plug in, screw type, terminal blocks allow for power supply wires of up to 1.5mm<sup>2</sup> ( 2.5mm<sup>2</sup> for relay connections) to be fitted. Two 10 way terminal plug in data terminals are provided allowing up to 16 data input lines. Four ground (GND) terminals are provided on the data input connector, these grounds are all common i.e. any of the ground terminals can be used. See the “Weighted digital input operation & electrical connections” chapter for weighted digital input connections.

For certain BCD input configurations some of the 16 input lines can be allocated to remote decimal point position selection and a display hold input, refer to the appropriate drawing in this chapter for wiring details.

The programming button and programming download connector on the input circuit board are used for updating software via a PC. This allows users to download software updates or requested special software changes via a PC without the need to return the instrument to the manufacturer. Details of use will be provided with the updated software, the use of this input is not covered further in this manual.

#### Instrument Data Input Connectors

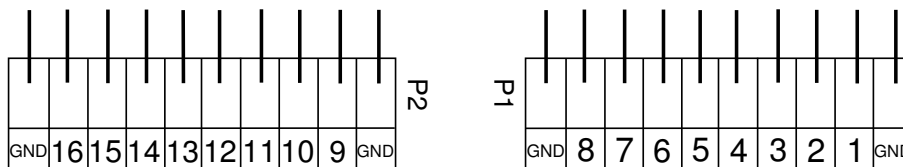

#### Input Circuit Board Layout

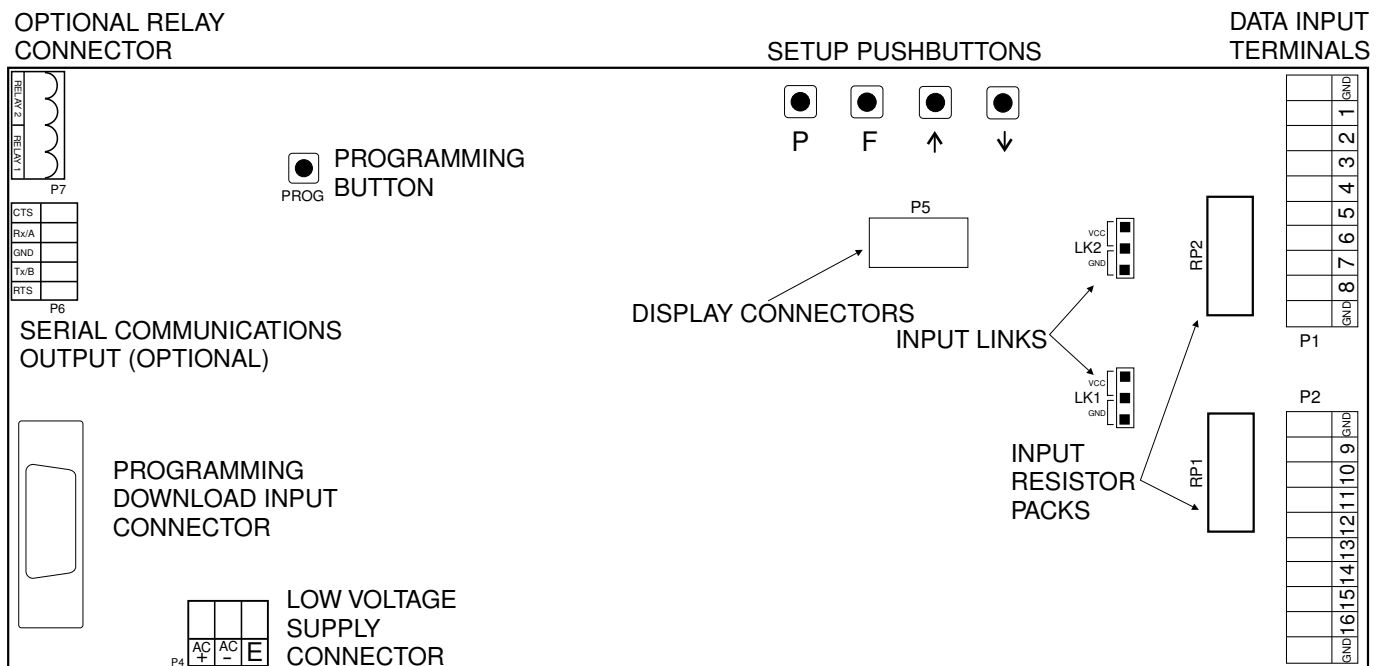

#### Resistor Pack & Link Settings

Input	RP1 & 2	LK1 & 2
Voltage free	100 Ohms	VCC
5V	100 Ohms	GND
12V to 24V	10k Ohms	GND
48V	22k Ohms	GND

### 3.1 Power supply connections

#### INPUT CONNECTOR ON INPUT CIRCUIT BOARD

THE INPUT TO THIS CONNECTOR WILL BE EITHER LOW VOLTAGE AC FROM THE POWER SUPPLY TRANSFORMER OR DC FROM THE ISOLATED DC SUPPLY CIRCUIT BOARD OR 24VDC NON ISOLATED SUPPLY

AC from power transformer  
or DC - from DC isolator board  
or - DC from 24VDC supply

AC from power transformer  
or DC + from DC isolator board  
or + DC from 24VDC supply

NOTE: ON SOME MODELS THE LOW VOLTAGE DC OR AC IS FED DIRECTLY TO THE DISPLAY PCB AND NOT TO THIS CONNECTOR

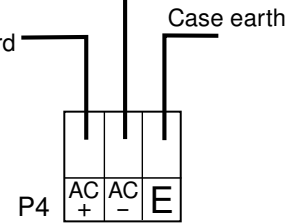

#### Isolated DC PCB for 100 & 200 mm displays

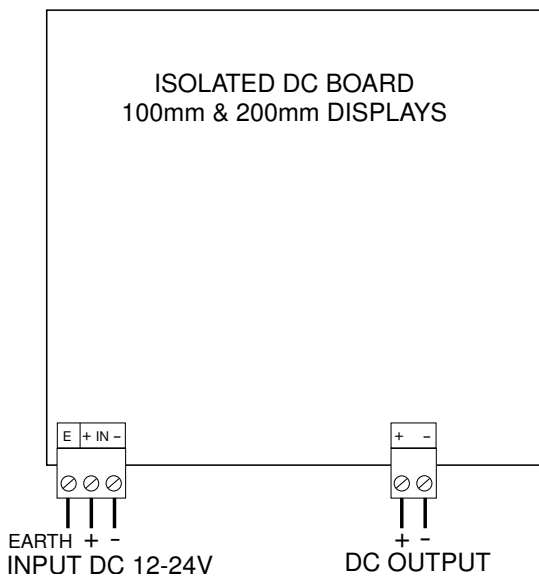

#### Isolated DC PCB for 57mm 4 digit display

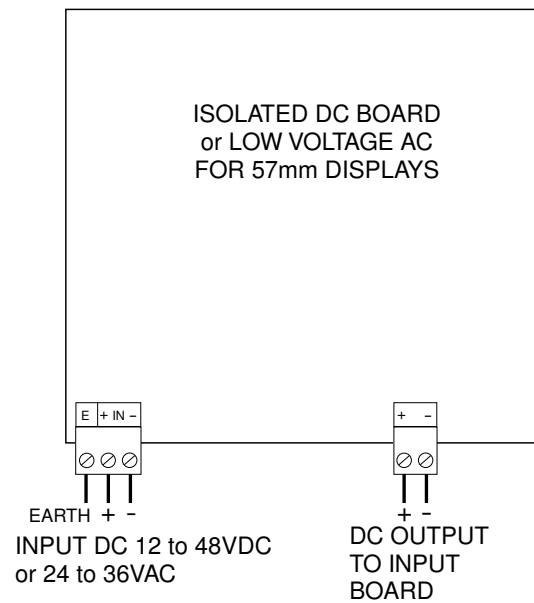

#### AC supply input PCB for 57mm 4 digit display

Multi tap AC input connections for 100mm & 200mm displays shown overleaf.

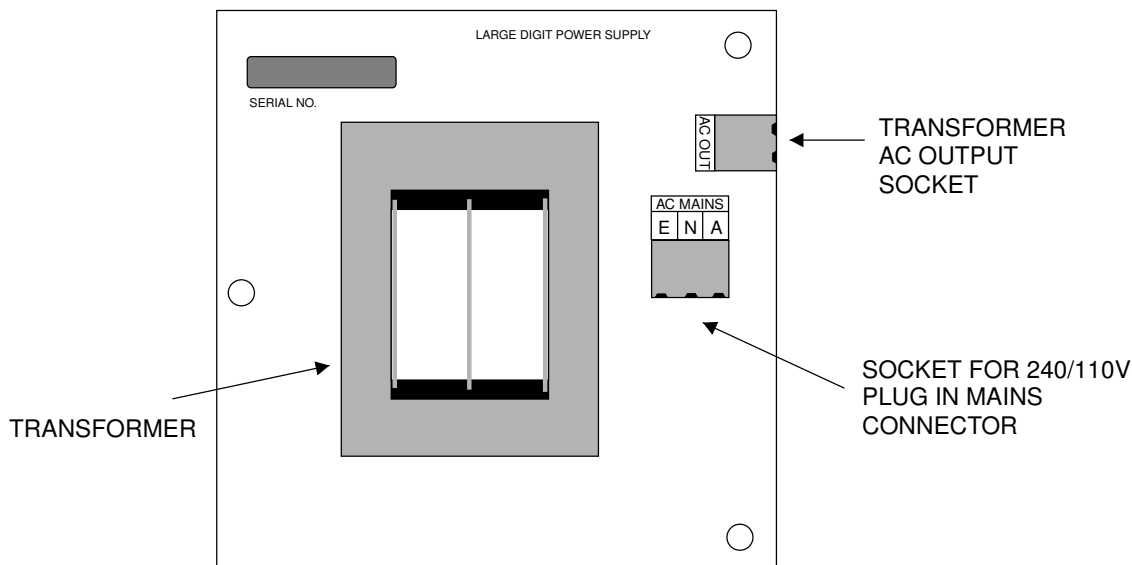

240 & 110VAC supplies.  
For 100mm/200mm LED or 100mm  
electromagnetic display types only.

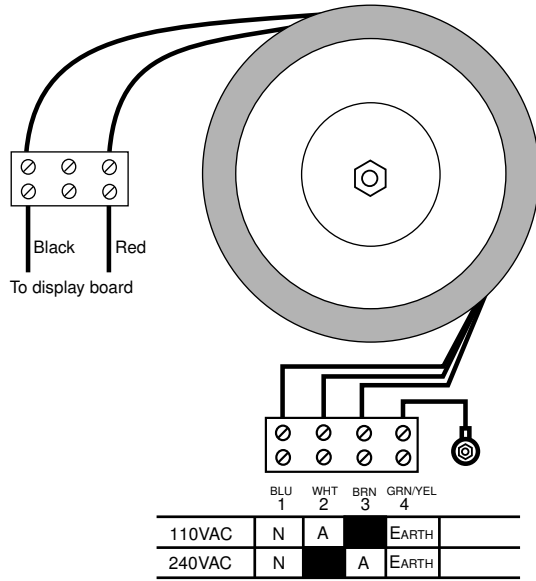

Low voltage AC supplies.  
For 100mm/200mm LED or 100mm  
electromagnetic display types only.

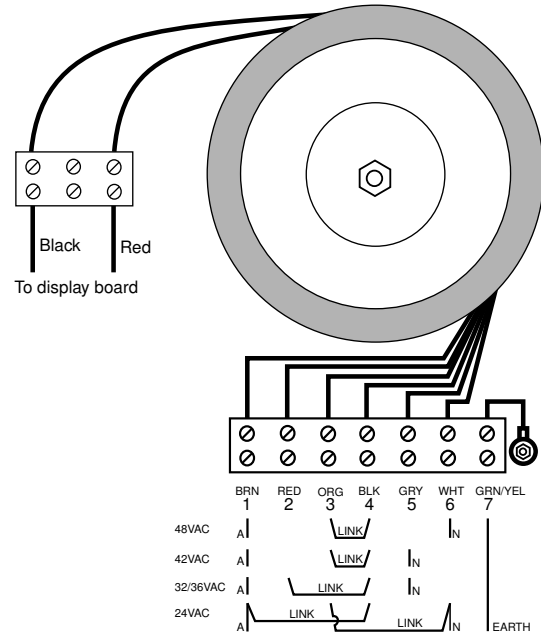

Wiring examples 240VAC & 110VAC

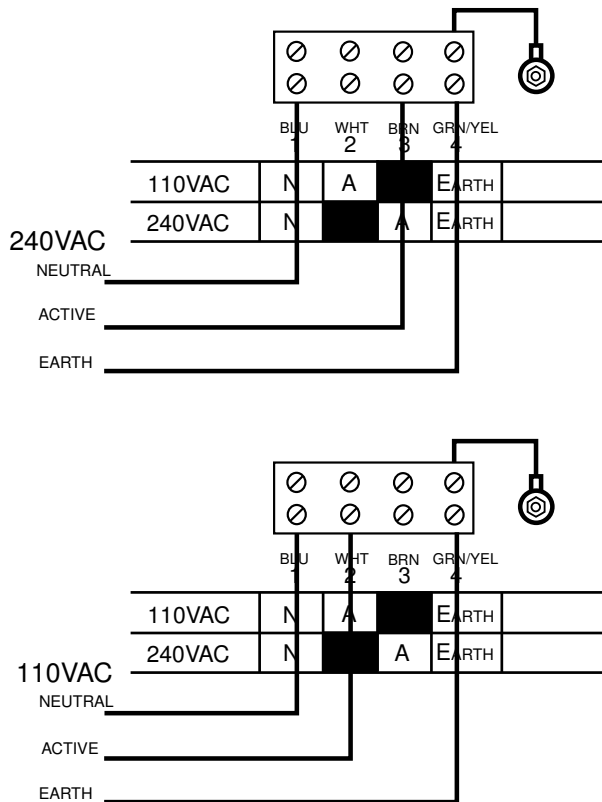

Wiring examples low voltage AC

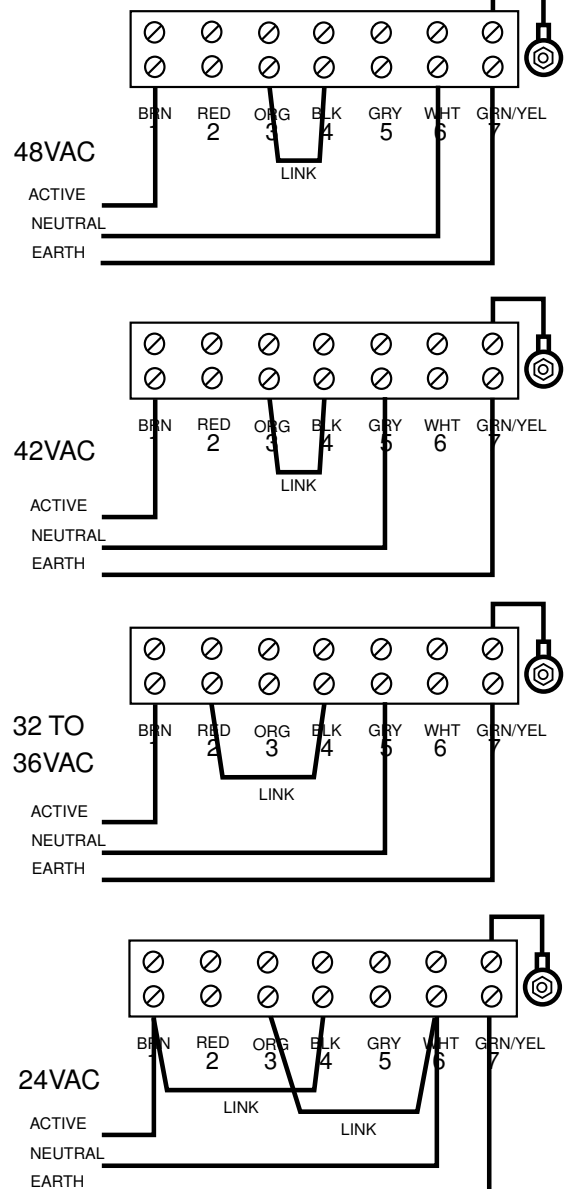

Important note: the 240V & 110V supplies use the same transformer, low voltage instruments use a different transformer. Do not use a low voltage transformer for 240V or 110V or vice versa.

### 3.2 Input wiring examples

WIRING EXAMPLE - VOLTAGE FREE CONTACT

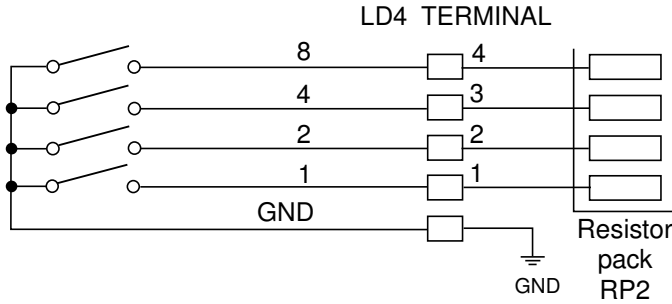

WIRING EXAMPLE - SIGNAL VOLTAGE

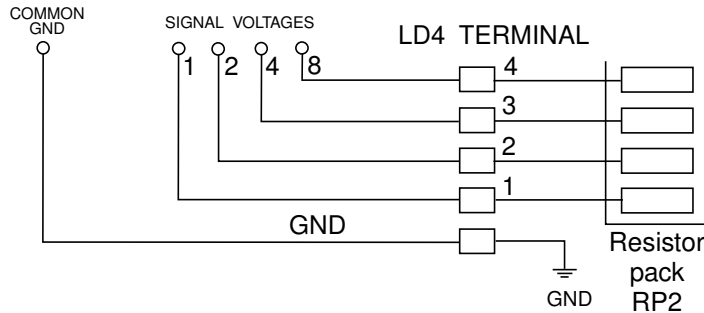

### 3.3 Optional relay connections

RELAYS ARE OPTIONAL AND RELAY FUNCTIONS WILL BE SEEN ONLY WHEN THE RELAYS ARE FITTED. RELAYS ARE PROGRAMMABLE FOR NORMALLY OPEN OR NORMALLY CLOSED OPERATION. RATING IS 240V RMS @ 5A INTO A RESISTIVE LOAD.

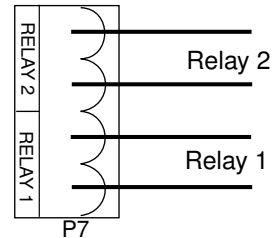

### 3.4 Optional serial communications connections

SERIAL COMMUNICATIONS IS OPTIONAL, CONNECTORS AND CIRCUITRY WILL ONLY BE FITTED IF THE INSTRUMENT WAS ORDERED WITH THE SERIAL COMMUNICATIONS OPTION.

NOTE: WHEN CONNECTING USING RS232 THE Tx LINE AT THE LD4 CONNECTS TO THE Rx LINE AT THE DEVICE IT IS COMMUNICATING WITH. LIKEWISE THE Rx LINE AT THE LD4 CONNECTS TO Tx.

RS485 TERMINATING LINK. THE LINK SHOULD BE IN FOR LONG CABLE RUNS. IF MULTIPLE INSTRUMENTS ARE CONNECTED INSERT THE LINK IF THE LD4 IS THE FIRST AND LAST UNIT ON THE LINE. WHEN USING RS485 CONNECTIONS ARE A TO A AND B TO B

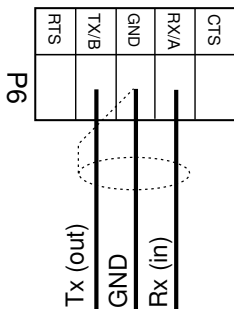

RS232 communications use 3 core shielded cable

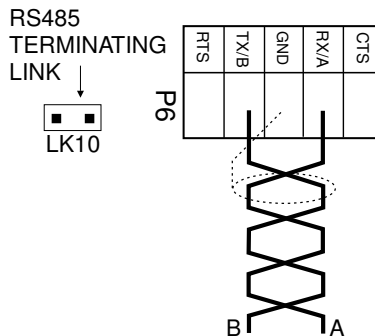

RS485 communications use twisted pair shielded cable

### 3.6 Data input connections

The following pages show the choice of input configurations. The input type is set by the **SELE** and **INPE** functions. Refer to the "Weighted digital input operation & electrical connections" chapter for wiring details of weighted inputs.

## PARALLEL BCD INPUT

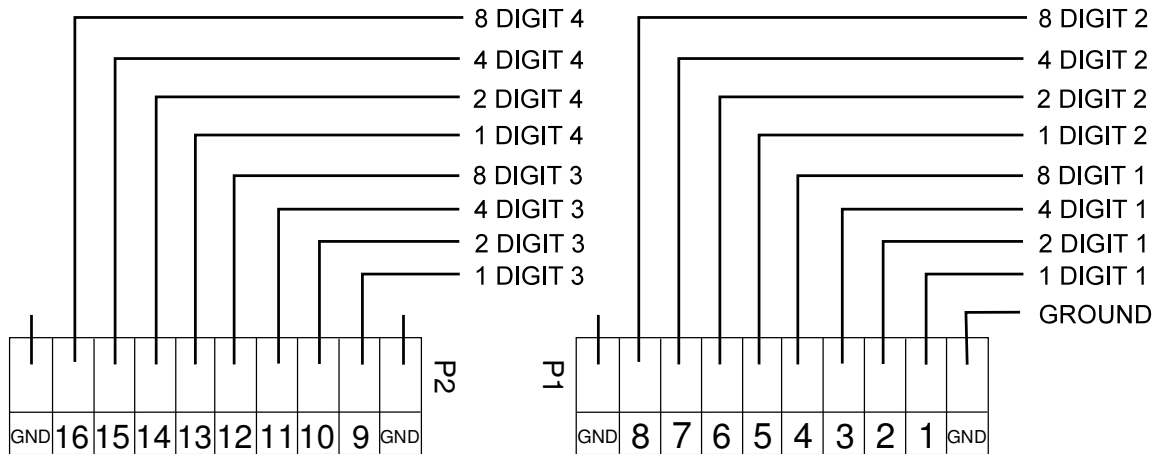

Input circuit BCD input parallel connection

Note all GND terminals on connectors P1 & P2 are common.

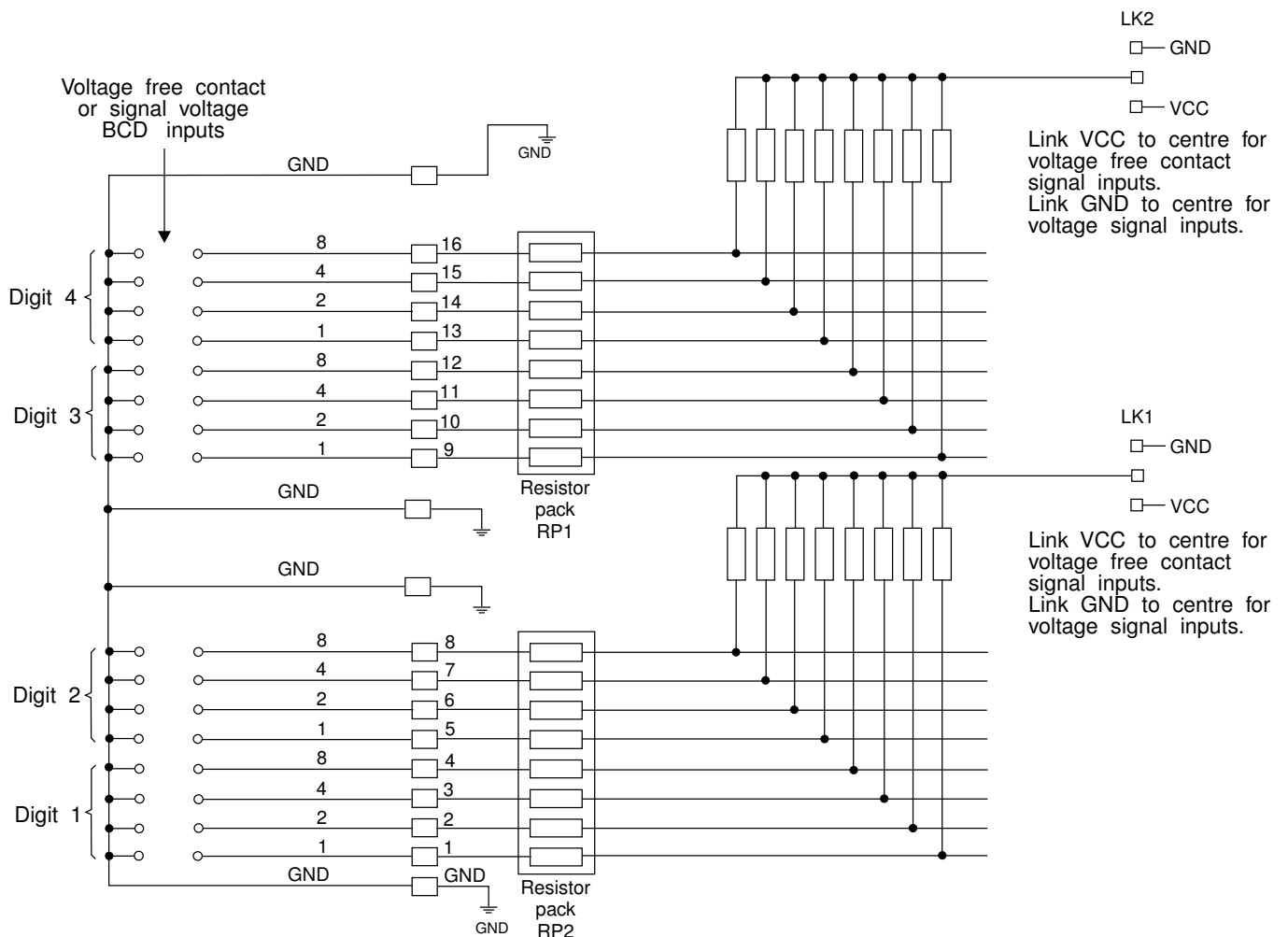

# STROBED BCD INPUT

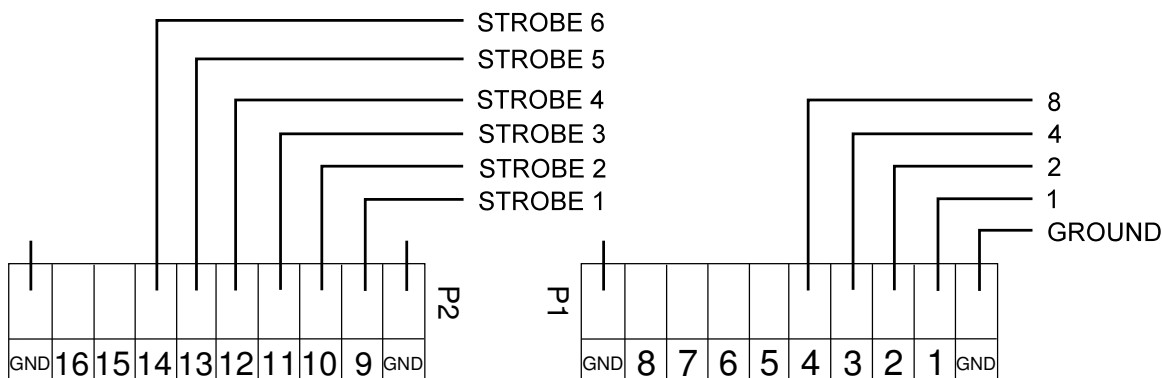

Input circuit BCD input strobed connection  
 Note all GND terminals on connectors P1 & P2 are common.

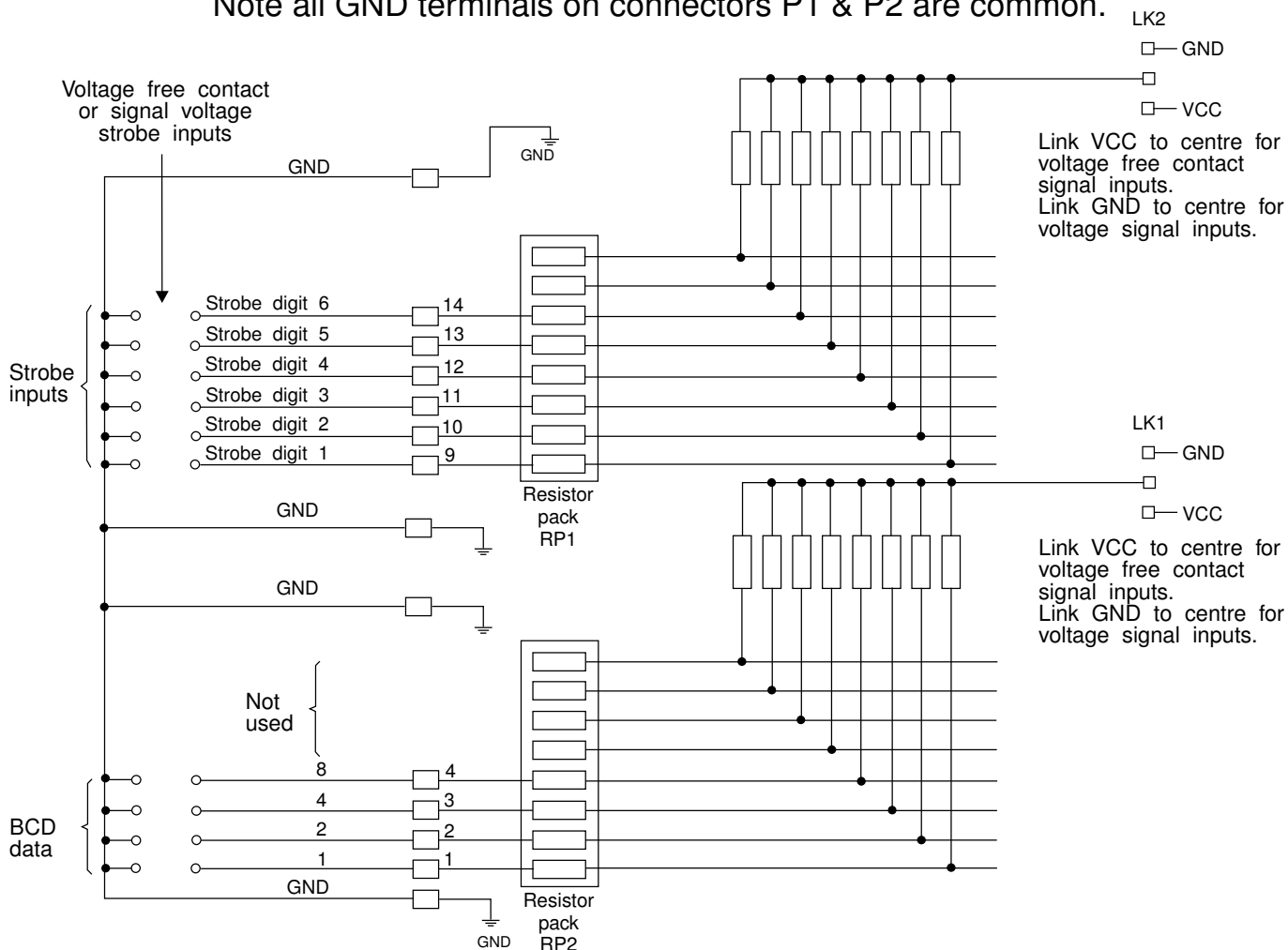

## Strobe mode operation

1. Set data value
2. Activate required strobe input when ready

## Example

If BCD data 1001 is placed on the input and the strobe input for digit 2 is activated a value of 9 will be sent to digit 2.

# ADDRESSED BCD INPUT

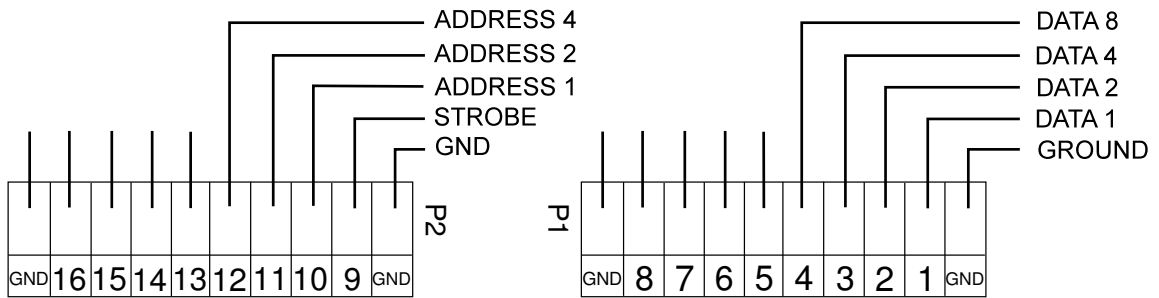

Input circuit BCD input addressed connection  
Note all GND terminals on connectors P1 & P2 are common.

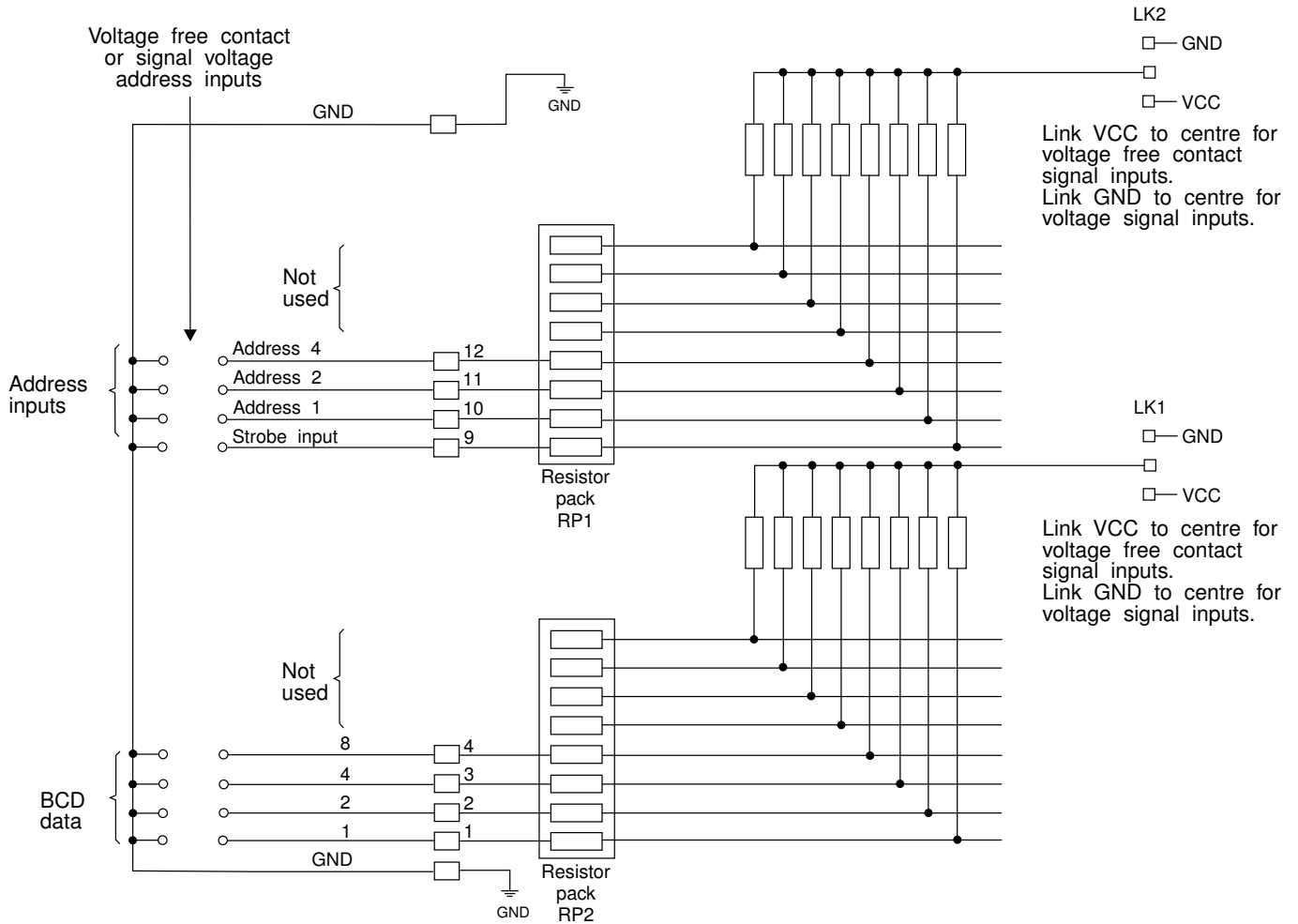

## Addressed mode operation

1. Set data value
2. Set address
3. Activate strobe input when ready

Address input	4	2	1	Digit addressed
Status	Inactive	Inactive	Inactive	1
	Inactive	Inactive	<b>Active</b>	2
	Inactive	<b>Active</b>	Inactive	3
	Inactive	<b>Active</b>	<b>Active</b>	4
	<b>Active</b>	Inactive	Inactive	5
	<b>Active</b>	Inactive	<b>Active</b>	6

## Example

If BCD data 1000 is placed on the input and the address is 011 (digit 4) when the strobe input is activated a value of 8 will be sent to digit 4.

# PARALLEL BINARY INPUT (ALSO USED FOR GRAY CODE)

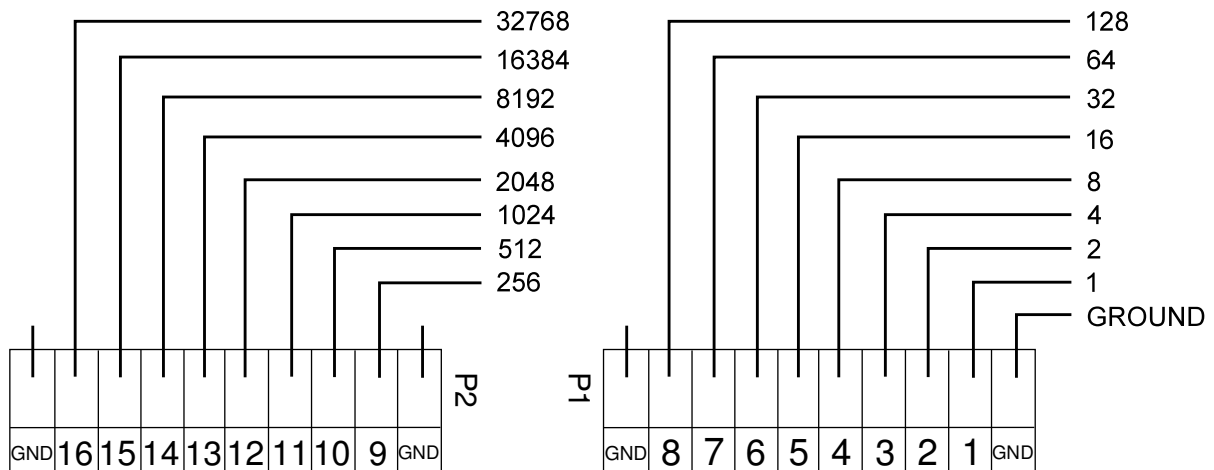

Input circuit binary input parallel connection.  
 Note all GND terminals on connectors P1 & P2 are common.

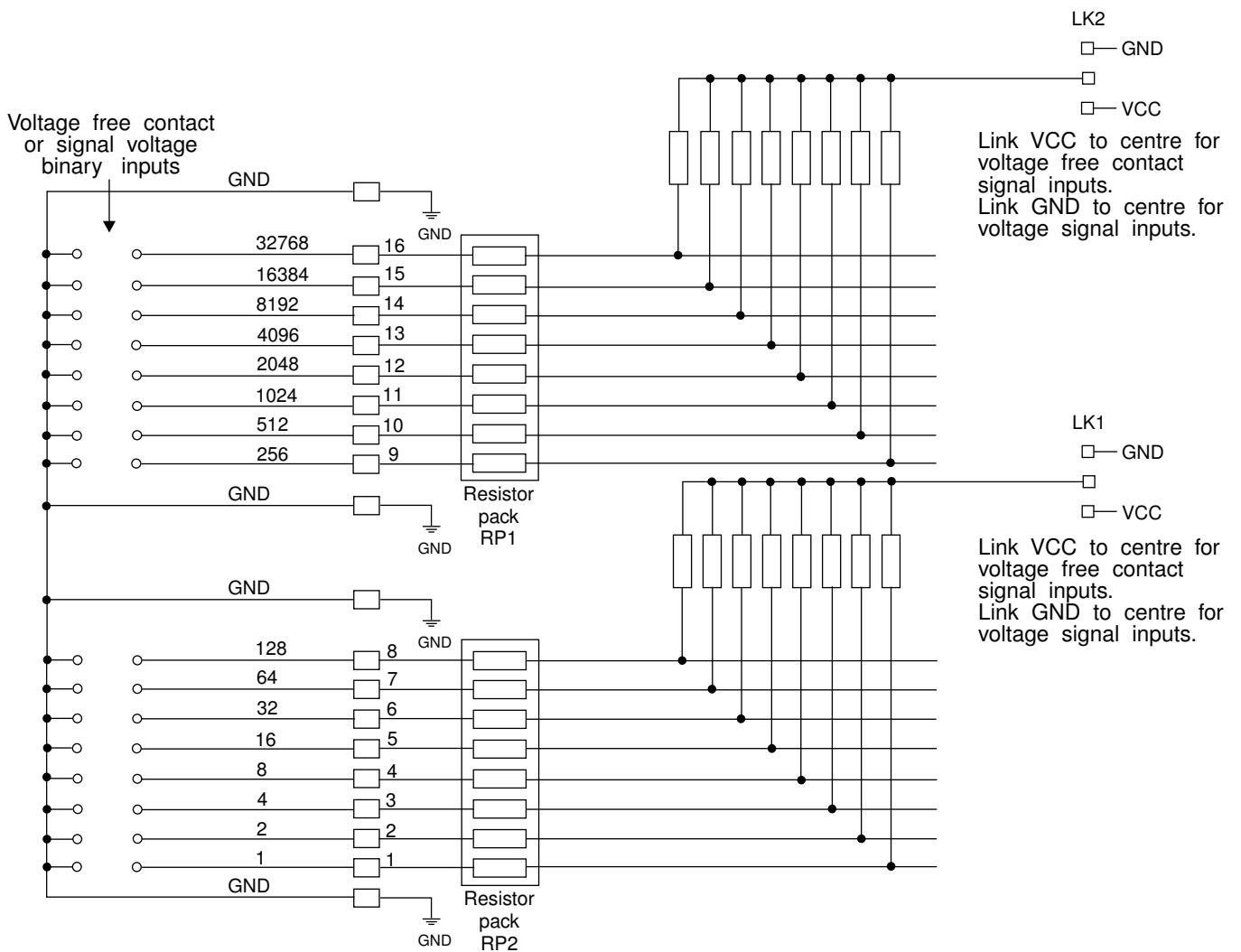

# STROBED BINARY INPUT (ALSO USED FOR GRAY CODE)

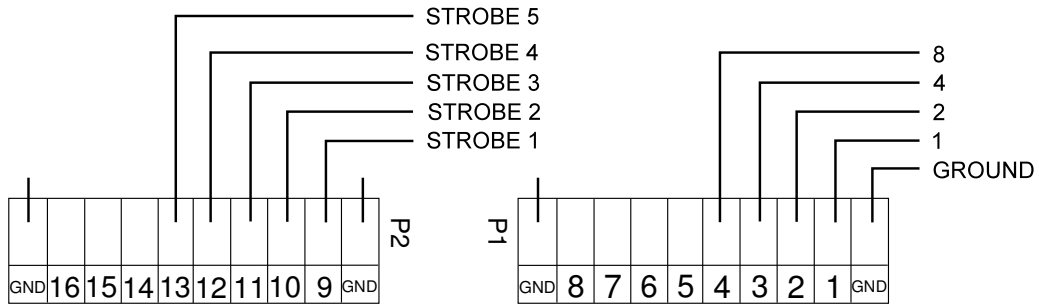

Input circuit binary input strobed connection  
 Note all GND terminals on connectors P1 & P2 are common.

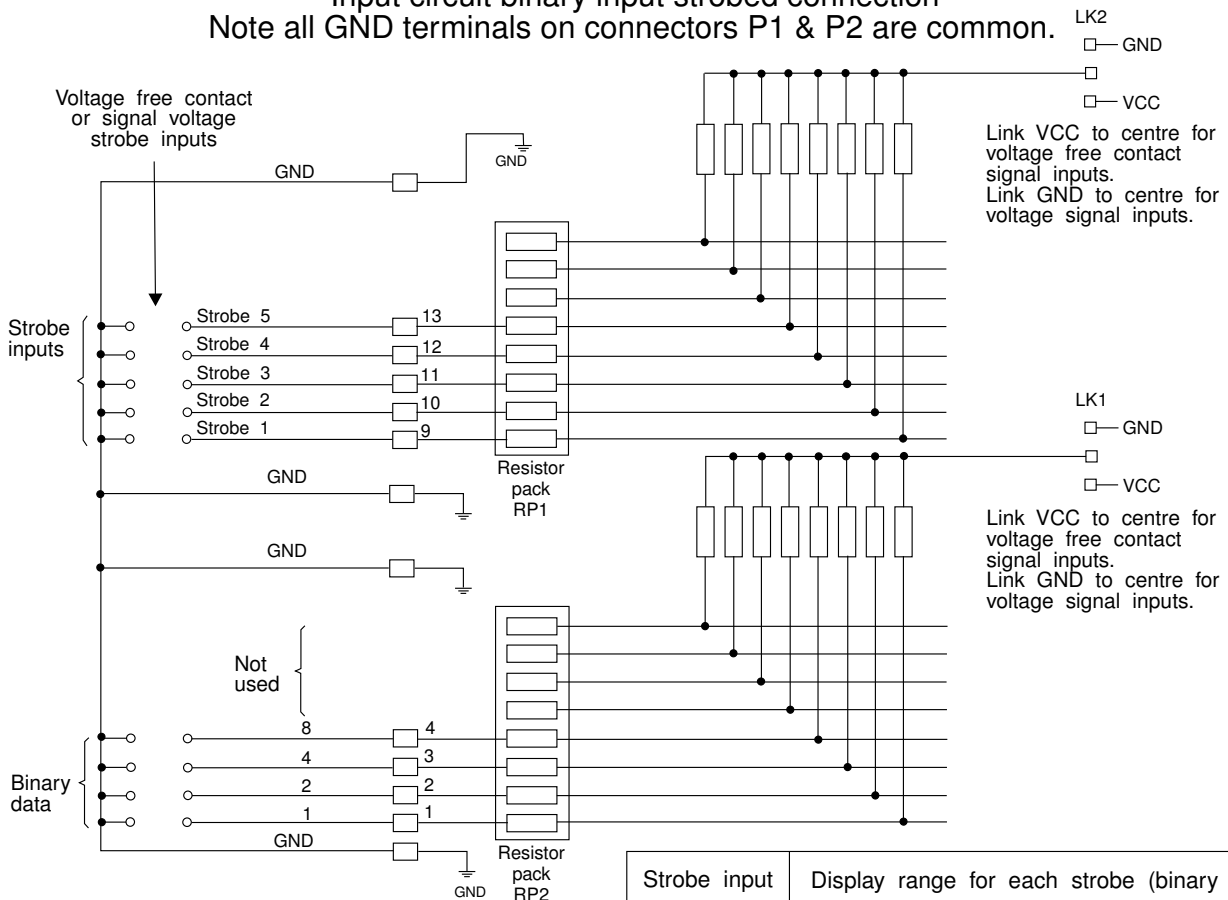

## Strobe mode operation

1. Set data value
2. Activate required strobe input when ready

### Example 1

1. Data value set to 0100
2. Strobe 1 activated - a value of 4 (0100 in binary) is added to the display.

### Example 2

1. Data value set to 0100
2. Strobe 2 activated - a value of 64 (0100 0000 in binary) is added to the display.

### Example 3

1. Data value set to 0100
3. Strobe 3 activated - a value of 1024 (0100 0000 0000 in binary) is added to the display.

Strobe input	Display range for each strobe (binary input)
1	0000 to 1111 adds 0 to 15
2	0001 to 1111 adds 16 to 240
3	0001 to 1111 adds 256 to 3840
4	0001 to 1111 adds 4096 to 61440
5	0001 to 1111 adds 65536 to 983040
Note 999999 is the largest number which can be displayed on a 6 digit display	

# ADDRESSED BINARY INPUT (ALSO USED FOR GRAY CODE)

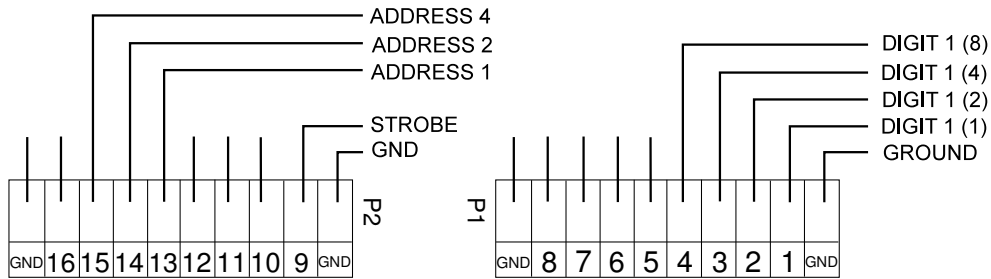

Input circuit binary input addressed connection.  
Note all GND terminals on connectors P1 & P2 are common.

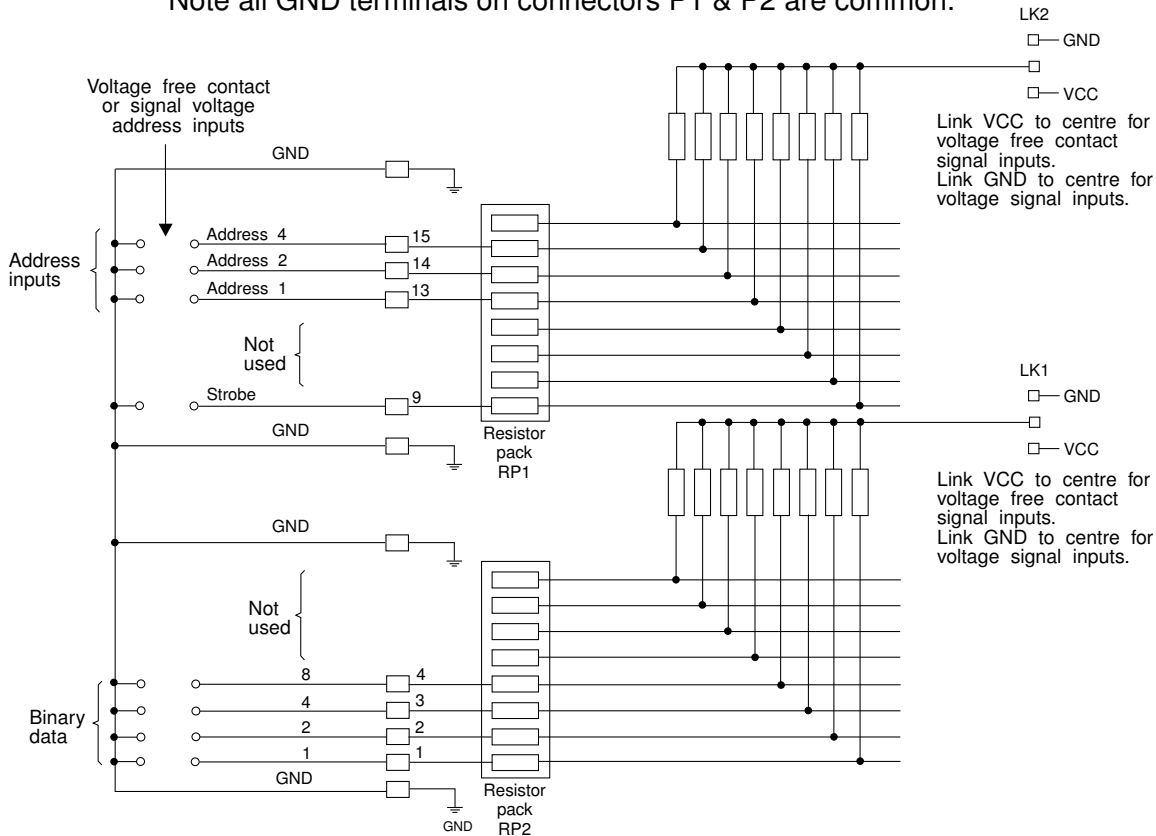

## Addressed binary mode operation

1. Set data value
2. Set address
3. Activate strobe

Status	Address input			Display range for each address (binary input)
	4	2	1	
Inactive	Inactive	Inactive	Inactive	0000 to 1111 adds 0 to 15
Inactive	Inactive	Inactive	<b>Active</b>	0001 to 1111 adds 16 to 240
Inactive	Inactive	<b>Active</b>	Inactive	0001 to 1111 adds 256 to 3840
Inactive	<b>Active</b>	Inactive	<b>Active</b>	0001 to 1111 adds 4096 to 61440
<b>Active</b>	Inactive	Inactive	Inactive	0001 to 1111 adds 65536 to 983040

Note 999999 is the largest number which can be displayed on a 6 digit display

### Example 1

1. Data value set to 0100
2. Address set to 000 (digit 1)
3. Strobe activated - a value of 4 (0100 in binary) is added to the display.

### Example 2

1. Data value set to 0100
2. Address set to 001 (digit 2)
3. Strobe activated - a value of 64 (0100 0000 in binary) is added to the display.

### Example 3

1. Data value set to 0100
2. Address set to 010 (digit 3)
3. Strobe activated - a value of 1024 (0100 0000 0000 in binary) is added to the display.

### 3.5 Remote decimal point selection and display hold

For up to 3 digit parallel BCD or addressed BCD or strobed BCD inputs terminals 13, 14 & 15 may be used to select the decimal point position. To allow these inputs to be used in this manner the **dp ! npt** function must be set to **on**. When the **dp ! npt** function is set to **on** the software decimal point selection set at the **dcpt** function will be ignored. The table below shows the input requirements for remote decimal point selection.

The display hold input will hold the current display value when activated. The **! npt hold** function must be set to **on** to enable the display hold input. The **hold pol** function may be set to **H**, or **L**, this sets the input logic level at terminal 16 for display hold. The display hold input is available for use with up to 4 digit parallel BCD or addressed BCD or strobed BCD.

Decimal point positions 8 digit display example.

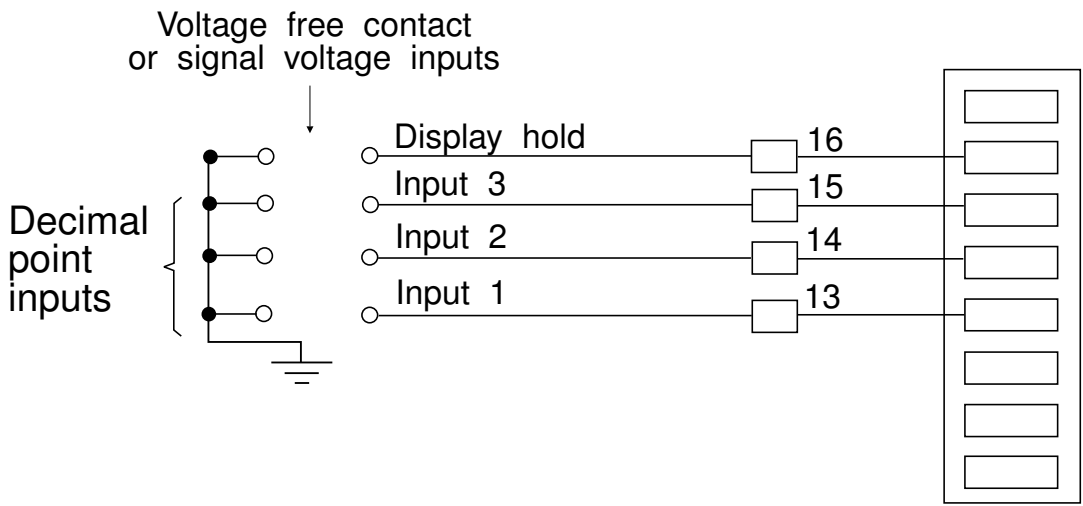

Decimal point selection table

	No decimal points	dp1 on	dp2 on	dp3 on	dp4 on	dp5 on	dp6 on	dp7 on
Input 1	Inactive	Active	Inactive	Active	Inactive	Active	Inactive	Active
Input 2	Inactive	Inactive	Active	Active	Inactive	Inactive	Active	Active
Input 3	Inactive	Inactive	Inactive	Inactive	Active	Active	Active	Active









## 4 Explanation of functions



The LD setup and calibration functions are configured through a push button sequence. Two levels of access are provided for setting up and calibrating.

**FUNC** mode (simple push button sequence) allows access to commonly set up functions such as alarm setpoints.

**CAL** mode (power up sequence plus push button sequence) allows access to all functions including calibration parameters.

Refer to section 1.1 for details of how to enter **CAL** & **FUNC** modes. A list of functions available follows:

Function	Description
<b>R1Lo</b>	First optional relay low setpoint (binary, Gray code, whole number BCD ( <b>bc dCODE = 0</b> ) and weighted digital inputs only). The <b>R1Lo</b> function displays and sets the low setpoint value for the alarm relay. The low alarm setpoint may be disabled by pressing the  and  pushbuttons simultaneously. When the alarm is disabled the display will indicate <b>OFF</b> . Use  or  to adjust the setpoint value if required. The alarm will activate when the displayed value is lower than the setpoint value. Each relay may be configured with both a low and high setpoint if required. When both a low and high setpoint is used the relay will be activated when the display reading moves outside the band set between low and high setpoints.
<b>R2Lo</b>	Second optional relay low setpoint (binary, Gray code, whole number BCD ( <b>bc dCODE = 0</b> ) and weighted digital inputs only). See <b>R1Lo</b> above for description.
<b>R1H.</b>	First optional relay high setpoint (binary, Gray code, whole number BCD ( <b>bc dCODE = 0</b> ) and weighted digital inputs only). Displays and sets the high setpoint value for the alarm relay. The high alarm setpoint may be disabled by pressing the  and  pushbuttons simultaneously. When the alarm is disabled the display will indicate <b>OFF</b> . Use  or  to adjust the setpoint value if required. The alarm will activate when the displayed value is higher than the setpoint value. Each relay may be configured with both a low and high setpoint if required, if so the relay will be activated when the display reading moves outside the band set between low and high setpoints.
<b>R2H.</b>	Second optional relay high setpoint (binary, Gray code, whole number BCD ( <b>bc dCODE = 0</b> ) and weighted digital inputs only). See <b>R1H.</b> above for description.
<b>R1HY &amp; R2HY</b>	Alarm hysteresis [deadband] for optional relays (binary, Gray code, whole number BCD ( <b>bc dCODE = 0</b> ) and weighted digital inputs only) - displays and sets the alarm hysteresis limit and is common for both high and low setpoint values. The hysteresis value may be used to prevent too frequent operation of the setpoint relay when the measured value stays close to the setpoint. Without a hysteresis setting (e.g. <b>R2HY</b> set to zero) the alarm will activate when the display value goes above the alarm setpoint (for high alarm) and will reset when the display value falls below the setpoint, this can result in repeated on/off switching of the relay at around the setpoint value. The hysteresis setting operates as follows: <p>In the high alarm mode, once the alarm is activated the input must fall below the setpoint value minus the hysteresis value to reset the alarm.  e.g. if <b>R2H.</b> is to <b>50.0</b> and <b>R2HY</b> is set to <b>3.0</b> then the setpoint output relay 2 will activate once the display value goes above <b>50.0</b> and will reset when the display value goes below <b>47.0</b> (50.0 minus 3.0).</p> <p>In the low alarm mode, once the alarm relay is activated the input must rise above the setpoint value plus the hysteresis value to reset the alarm.  e.g. if <b>R2Lo</b> is to <b>20.0</b> and <b>R2HY</b> is set to <b>10.0</b> then the alarm output relay 2 will activate when the display value falls below <b>20.0</b> and will reset when the display value goes above <b>30.0</b> (20.0 plus 10.0).</p> <p>The hysteresis units are expressed in displayed engineering units.</p>

<b>A 1tE &amp; A2tE</b>	Alarm trip time for optional relays (binary, Gray code, whole number BCD ( <b>bcdCODE = 0</b> ) and weighted digital inputs only) - displays and sets the alarm trip time and is common for both alarm high and low setpoint values. The trip time is the delay time before the alarm relay will activate, or trip, when an alarm condition is present. The alarm condition must be present continuously for the trip time period before the alarm will trip. This function is useful for preventing an alarm trip due to short non critical deviations from setpoint. The trip time is selectable over <b>0</b> to <b>60</b> seconds.
<b>A 1rE &amp; A2rE</b>	Alarm reset time for optional relays (binary, Gray code, whole number BCD ( <b>bcdCODE = 0</b> ) and weighted digital inputs only) - displays and sets the alarm relay reset time. With the alarm condition is removed the alarm relay will stay in its alarm condition for the time selected as the reset time. The reset time is selectable over <b>0</b> to <b>60</b> seconds.
<b>A 1n.o/ A 1n.c/ A2n.o/ A2n.c</b>	Alarm normally open or normally closed for optional relays (binary, Gray code, whole number BCD ( <b>bcdCODE = 0</b> ) and weighted digital inputs only) - displays and sets the setpoint alarm relay action to normally open (de-energised) or normally closed (energised), when no alarm condition is present. A normally closed alarm is often used to provide a power failure alarm indication.
<b>A2.SP, A2.t 1.</b>	Relay 2 operation independent setpoint or trailing setpoint for optional relay (binary, Gray code, whole number BCD ( <b>bcdCODE = 0</b> ) and weighted digital inputs only) - relay 2 may be programmed to operate with an independent setpoint setting or may be linked (or trailing) to operate at a fixed difference to relay 1 setpoint. The operation is as follows: Alarm relay 1 ( <b>A 1</b> ) is always independent. Alarm relay 2 ( <b>A2</b> ) may be independent or may be linked to Alarm 1. The operation of each alarm is selectable within the <b>FUNC</b> mode by selecting, for example, (Alarm 2) <b>A2.SP</b> = Alarm 2 normal setpoint or <b>A2.t 1</b> = Alarm 2 trailing Alarm 1. For trailing set points the setpoint value is entered as the difference from the setpoint being trailed. If the trailing setpoint is to operate ahead of the prime setpoint then the value is entered as a positive number and if operating behind the prime setpoint then the value is entered as a negative number. For example, with Alarm 2 set to trail alarm 1, if <b>A 1H</b> is set to 1000 and <b>A2H</b> is set to 50 then Alarm relay 1 will activate at 1000 and Alarm relay 2 will activate at 1050 (i.e. 1000 + 50). If Alarm 2 had been set at -50 then Alarm relay 2 would activate at 950 (i.e. 1000 - 50).
<b>br9E</b>	Display brightness - displays and sets the digital display brightness. The display brightness is selectable from <b>1</b> to <b>63</b> where <b>1</b> = lowest intensity and <b>63</b> = highest intensity. This function is useful for improving the display readability in dark areas or to reduce the power consumption of the instrument.
Functions below are accessible only via <b>CAL</b> mode or if <b>ACCS</b> is set to <b>ALL</b>	
<b>br9E AUTo</b>	Automatic display brightness adjustment ( <b>on</b> or <b>OFF</b> ). The automatic brightness adjustment uses the inbuilt light sensor to gauge the required brightness level for the environment. The high and low brightness limits are set at the <b>br9E Hi 9H</b> and <b>br9E Lo</b> functions described below.
<b>br9E Hi 9H</b>	Automatic brightness high level ( <b>10</b> to <b>63</b> ) - seen only when <b>br9E AUTo</b> is set to <b>on</b> . The high brightness level sets the maximum brightness which the automatic brightness control can achieve with <b>63</b> being the highest intensity.
<b>br9E Lo</b>	Automatic brightness low level ( <b>1</b> to <b>63</b> ) - seen only when <b>br9E AUTo</b> is set to <b>on</b> . The low brightness level sets the minimum brightness which the automatic brightness control can achieve with <b>63</b> being the highest intensity.
<b>dCEt</b>	Decimal point selection - displays and sets the decimal point. By pressing the  or  pushbuttons the decimal point position may be set. The display will indicate as follows: <b>0</b> (no decimal point), <b>0. 1</b> (1 decimal place), <b>0.02</b> (2 decimal places), <b>0.003</b> (3 decimal places) etc. For addressed, strobed and 4 digit parallel BCD inputs the decimal points can be selected remotely via the signal levels on the input terminals. See <b>dP , nPE</b> function and "Electrical Installation" chapter for details. When remote decimal point selection is used the <b>dCEt</b> function settings are ignored.

<b>P.but</b>	<p><b>P</b> button function.</p> <p>The <b>P</b> button may be set to operate one selected function. Note the P button functions do not operate in BCD mode.</p> <p>Functions available are: <b>NONE</b>, <b>H</b>, <b>Lo</b>, <b>H, Lo</b></p> <p><b>NONE</b> - no function required.</p> <p><b>H</b>, - peak memory. The peak value stored in memory will be displayed when the <b>P</b> button is pressed, if the button is pressed momentary then the display will return to normal measurement after 20 seconds. If the button is held for 1 to 2 seconds or the power is removed from the instrument then the memory will be reset.</p> <p><b>Lo</b> - valley memory. The minimum value stored in memory will be displayed. Otherwise operates in the same manner as the <b>H</b>, function.</p> <p><b>H, Lo</b> - toggle between <b>H</b>, and <b>Lo</b> displays. This function allows the remote input to be used to toggle between peak and valley memory displays. The first operation of the <b>P</b> button will cause the peak memory value to be displayed, the next operation will give a valley memory display. <b>PH</b>, or <b>PLo</b> will flash before each display to give an indication of display type.</p>
<b>ACCS</b>	<p>Access mode - the access mode function <b>ACCS</b> has four possible settings namely <b>OFF</b>, <b>ERSY</b>, <b>NONE</b> and <b>ALL</b>. If set to <b>OFF</b> the mode function has no effect on alarm relay operation. If set to <b>ERSY</b> the easy alarm access mode will be activated (requires optional alarm relay to be fitted). If set to <b>NONE</b> there will be no access to any functions via <b>FUNC</b> mode, entry via <b>CAL</b> mode must be made to gain access to alarm and calibration functions. If set to <b>ALL</b> then access to all functions, including calibration functions, can be gained via <b>FUNC</b> mode.</p>
<b>SPAC</b>	<p>Setpoint access - Sets the access to the optional alarm relay set points. The following choices are available: <b>R 1</b> - Allows setpoint access to alarm relay 1 settings only. <b>R 1-2</b> - Allows access to alarm relay 1 and 2 settings.</p>
<b>INP bits</b>	<p>Input bits - allows selection of the number of input bits from 1 to 16.</p>
<b>SIGN</b>	<p>Sign bit <b>on</b> or <b>OFF</b> (parallel binary input only) - Example: if set to <b>on</b> then, with 16 bit binary selected, the most significant digit will be used as the sign bit with 0 on the most significant digit being positive and 1 on the most significant digit being negative. e.g. 0111 1111 1111 1001 will show as <b>32761</b> on the display and 1111 1111 1111 1001 will show as <b>-7</b> (-7 being the two's compliment of 111 1111 1111 1001). Thus the display with 15 bits plus a sign bit can display any number from <b>-32768</b> to <b>32767</b>.</p> <p>If set to <b>OFF</b> none of the data bits will be treated as a sign bit and all values will be positive.</p>
<b>DISP RATE</b>	<p>Display rate - allows selection of display update rate from 1, 2, 4, 8, 16 or 32 updates per second.</p>
<b>DI, NP</b>	<p>Weighted digital input bits - seen only when <b>SET INP</b> is set to <b>DI, NP</b>. Allows the number of weighted digital inputs used to be set from 1 to 8. See "Weighted digital input operation &amp; electrical connections" chapter for a description of the <b>DI, NP</b> mode.</p>
<b>DI, 1, DI, 2 etc.</b>	<p>Weighting for digital input 1, 2 etc. - seen only when <b>SET INP</b> is set to <b>DI, NP</b>. Allows weighted values to be set for each of the digital inputs used. May be set to any value in the display range. See "Weighted digital input operation &amp; electrical connections" chapter for a description of the <b>DI, NP</b> mode.</p>
<b>SET INP</b>	<p>Set input - allows selection of binary (<b>bin</b>), BCD (<b>bcd</b>), Gray (<b>GRAY</b>) code input or a special weighted digital input (<b>DI, NP</b>). See "Weighted digital input operation" chapter for a description of the <b>DI, NP</b> mode.</p>
<b>INP</b>	<p>Input type - Allows selection of parallel (<b>PARL</b>), strobed (<b>Strob</b>) or addressed (<b>Addr</b>) input. See "Electrical Installation" chapter for wiring details.</p>
<b>DATA POL</b>	<p>Data polarity - Allows selection of active low (<b>Lo</b>) or active high (<b>H</b>,) data inputs.</p>
<b>Strob POL</b>	<p>Strobe polarity - Allows selection of active low (<b>Lo</b>) or active high (<b>H</b>,) strobe inputs.</p>

<b>bcd CODE</b>	BCD code - BCD inputs only i.e. <b>bcd</b> selected at <b>SEt: NPt</b> function - allows selection of special code characters as shown below. Select the format for non BCD digits, A to F: <b>0</b> - A to F (1010 to 1111) displays blanks <b>1</b> - A to F (1010 to 1111) displays <b>A, b, C, d, E, F</b> <b>2</b> - A to F (1010 to 1111) displays <b>-, C, I, O, o</b> , blank <b>3</b> - A to F (1010 to 1111) displays <b>A, L, H, I, o</b> , blank <b>4</b> - A to F (1010 to 1111) displays <b>O, C, F, -, -, -</b> <b>5</b> - A to F (1010 to 1111) displays <b>-, E, H, L, P</b> , blank										
<b>bcd di: 9t</b>	Number of BCD digits (1 to 5 or 1 to 4 for 4 digit display) - BCD inputs only i.e. <b>bcd</b> selected at <b>SEt: NPt</b> function - allows selection of the number of BCD digits to be displayed.										
<b>dP : NPt</b>	Remote decimal point selection - for addressed, strobed or 4 digit parallel BCD inputs only there is a choice of setting the decimal point place either in software or remotely via input terminals 13, 14 & 15. If selection is to be made via software the <b>dP: NPt</b> function must be set to <b>OFF</b> . If remote selection is required the <b>dP: NPt</b> function must be set to <b>on</b> . When the <b>dP: NPt</b> function is set to <b>on</b> the <b>dCPt</b> function setting is ignored. See section "Electrical Installation" chapter for details.										
<b>: NPt HOLD</b>	Remote display hold - for addressed, strobed or 4 digit parallel BCD inputs only there is a choice of assigning terminal 21 as a display hold input. If the <b>: NPt HOLD</b> function is set to <b>on</b> terminal 16 can be used to hold the display value (a latching switch or input level is normally required). If set to <b>OFF</b> terminal 16 cannot be used to hold the display. See <b>HOLD POL</b> function below.										
<b>HOLD POL</b>	Polarity for display hold input - for addressed, strobed or 4 digit parallel BCD inputs only. This function can be set to <b>H,</b> or <b>Lo</b> to select the logic level required for the display hold input on input terminal 16. The table below shows the effect of the <b>HOLD POL</b> function setting. The voltage levels at the hold input must be the same as the data voltage levels.										
	<table border="1"> <thead> <tr> <th><b>HOLD POL</b> setting</th> <th>LK1 &amp; 2 set to GND</th> <th>LK1 &amp; 2 set to VCC (voltage free inputs only)</th> </tr> </thead> <tbody> <tr> <td><b>Lo</b></td> <td>Low voltage or open circuit holds display. High voltage frees display.</td> <td>Low voltage holds display. High voltage or open circuit frees display.</td> </tr> <tr> <td><b>H,</b></td> <td>Low voltage or open circuit frees display. High voltage holds display.</td> <td>Low voltage frees display. High voltage or open circuit holds display.</td> </tr> </tbody> </table>		<b>HOLD POL</b> setting	LK1 & 2 set to GND	LK1 & 2 set to VCC (voltage free inputs only)	<b>Lo</b>	Low voltage or open circuit holds display. High voltage frees display.	Low voltage holds display. High voltage or open circuit frees display.	<b>H,</b>	Low voltage or open circuit frees display. High voltage holds display.	Low voltage frees display. High voltage or open circuit holds display.
<b>HOLD POL</b> setting	LK1 & 2 set to GND	LK1 & 2 set to VCC (voltage free inputs only)									
<b>Lo</b>	Low voltage or open circuit holds display. High voltage frees display.	Low voltage holds display. High voltage or open circuit frees display.									
<b>H,</b>	Low voltage or open circuit frees display. High voltage holds display.	Low voltage frees display. High voltage or open circuit holds display.									
<b>USEF SCALE</b>	User scale - allows binary, Gray or BCD ( <b>bcd CODE</b> function = 0 only) code inputs to be scaled to non standard display values - see "Scaled inputs" chapter for description.										
<b>CAL 1</b>	First scaling point - see "Scaled inputs" chapter for description.										
<b>CAL 2</b>	Second scaling point - see "Scaled inputs" chapter for description.										
<b>CAL OFFSt</b>	Scaling offset - see "Scaled inputs" chapter for description.										
<b>BRud</b>	Set baud rate (binary, Gray code, whole number BCD ( <b>bcd CODE</b> = 0) and weighted digital inputs only) - seen only with serial output option. Refer to the RS232/RS485 Commands chapter if this option is fitted. Select from <b>300 . 600 . 1200 . 2400 . 4800 . 9600 . 19.2</b> or <b>38.4</b> .										
<b>Prty</b>	Set parity (binary, Gray code, whole number BCD ( <b>bcd CODE</b> = 0) and weighted digital inputs only) - seen only with serial output option. . Refer to the RS232/RS485 Commands chapter if this option is fitted. Select parity check to either <b>NONE, EVEN</b> or <b>odd</b> .										

<b>0.Pub</b>	<p>Set serial interface mode (binary, Gray code, whole number BCD (<b>bcdCODE = 0</b>) and weighted digital inputs only) - seen only with serial output option. Refer to the RS232/RS485 Commands chapter if this option is fitted.</p> <p>Select <b>NONE</b>, <b>d.SP</b>, <b>Cont</b>, <b>POLL</b> or <b>R.buS</b>  Allows user to select the serial interface operation as follows:-</p> <p><b>NONE</b> No serial communications required.</p> <p><b>d.SP</b> Sends image data from the display without conversion to ASCII. This mode is used only when the instrument is communicating with a slave display of the same manufacture.</p> <p><b>Cont</b> Sends ASCII form of display data every time display is updated.</p> <p><b>POLL</b> Controlled by computer or PLC as host. Host sends command via RS232/485 and instrument responds as requested.</p> <p><b>R.buS</b> A special mode used when communicating with the optional Windows compatible download software. A separate user manual is provided with this software.</p>
<b>Addr</b>	<p>Set unit address for polled (<b>POLL</b>) mode (0 to 31)) (binary, Gray code, whole number BCD (<b>bcdCODE = 0</b>) and weighted digital inputs only) - seen only with serial output option. . Refer to the RS232/RS485 Commands chapter if this option is fitted.</p> <p>Allows several units to operate on the same RS485 interface reporting on different areas etc. The host computer or PLC may poll each unit in turn supplying the appropriate address.</p> <p>The unit address ranges from 0 to 31 (DEC) but is offset by 32 (DEC) to avoid clashing with ASCII special function characters (such as &lt;STX&gt; and &lt;CR&gt;). Therefore 32 (DEC) or 20 (HEX) is address 0, 42 (DEC) or 2A (HEX) addresses unit 10.</p>
<b>SER. I TYPE</b>	<p>Set the serial input type for optional serial communications. Select either <b>NONE</b> for no communications, <b>232</b> for RS232 communications or <b>485</b> for RS485 communications. The <b>120</b> selection does not apply to this model.</p>

### Returning to normal measure mode

When the calibration has been completed it is advisable to return the instrument to the normal mode (where calibration functions cannot be tampered with). To return to normal mode, turn off power to the instrument, wait a few seconds and then restore power.

## 5 Function table

Initial display	Meaning of display	Next display	Default Setting	Record Your Settings
<i>R 1Lo</i>	Alarm relay low setpoint value	Setpoint value or <i>OFF</i>	<i>OFF</i>	
<i>R 1H,</i>	Alarm relay high setpoint value	Setpoint value or <i>OFF</i>	<i>OFF</i>	
<i>R2Lo</i>	Alarm relay low setpoint value	Setpoint value or <i>OFF</i>	<i>OFF</i>	
<i>R2H,</i>	Alarm relay high setpoint value	Setpoint value or <i>OFF</i>	<i>OFF</i>	
<i>R 1HY</i>	Alarm relay hysteresis	Hysteresis value in measured units	<i>1</i>	
<i>R2HY</i>	Alarm relay hysteresis	Hysteresis value in measured units	<i>1</i>	
<i>R 1t</i>	Alarm relay trip time	No of seconds before relay trips	<i>0</i>	
<i>R2t</i>	Alarm relay trip time	No of seconds before relay trips	<i>0</i>	
<i>R 1r</i>	Alarm relay reset time	Reset time in seconds	<i>0</i>	
<i>R2r</i>	Alarm relay reset time	Reset time in seconds	<i>0</i>	
<i>R 1n.o</i> or <i>R 1n.c</i>	Alarm relay action N/O or N/C	<i>R 1n.o</i> or <i>R 1n.c</i>	<i>R 1n.o</i>	
<i>R2n.o</i> or <i>R2n.c</i>	Alarm relay action N/O or N/C	<i>R2n.o</i> or <i>R2n.c</i>	<i>R2n.o</i>	
<i>R2.SP</i> or <i>R2.t</i>	Setpoint or trailing alarm	<i>R2.SP</i> or <i>R2.t</i>	<i>R2.SP</i>	
<i>br 9t</i>	Display brightness	<i>1</i> to <i>63</i>	<i>63</i>	
Functions below are accessible only via <i>CAL</i> mode or if the <i>ACCESS</i> function is set to <i>ALL</i> .				
<i>br 9t AUTO</i>	Automatic brightness control on or off	<i>on</i> or <i>OFF</i>	<i>OFF</i>	
<i>br 9t HI 9H</i>	Automatic high brightness level	<i>1</i> to <i>63</i>	<i>63</i>	
<i>br 9t Lo</i>	Automatic low brightness level	<i>1</i> to <i>63</i>	<i>10</i>	
<i>dCPt</i>	Decimal point position	<i>0, 0. 1, 0.02</i> etc	<i>0</i>	
<i>P.but</i>	<b>P</b> button function	<i>NONE, Hi, Lo</i> or <i>Hi, Lo</i>	<i>NONE</i>	
<i>ACCESS</i>	Access mode	<i>OFF, EASY, NONE</i> or <i>ALL</i>	<i>OFF</i>	
<i>SPAC</i>	Setpoint access	<i>R 1</i> or <i>R 1-2</i>	<i>R 1</i>	
<i>1 NPt b, t5</i>	Number of input bits	<i>1</i> to <i>16</i>	<i>16</i>	
<i>SI 9N</i>	Sign bit	<i>on</i> or <i>OFF</i>	<i>on</i>	
<i>di SP RATE</i>	Display update rate	<i>1, 2, 4, 8, 16</i> or <i>32</i>	<i>4</i>	
<i>d, nP</i>	Number of weighted digital inputs	<i>1</i> to <i>8</i>	<i>4</i>	
<i>d, 1, d, 2</i> etc	Value for each weighted digital input	Value in memory	<i>0</i>	
<i>SEt 1 NPt</i>	Set input type	<i>b, n, bcd, 9FRY</i> or <i>d, nP</i>	<i>bcd</i>	
<i>1 NPt</i>	Input mode	<i>PARL, Strb</i> or <i>Addr</i>	<i>PARL</i>	
<i>dAR POL</i>	Input data polarity	<i>Lo</i> or <i>Hi</i>	<i>Lo</i>	
<i>Strb POL</i>	Strobe input polarity	<i>Lo</i> or <i>Hi</i>	<i>Hi</i>	
<i>bcd CODE</i>	BCD code	<i>0, 1, 2, 3, 4</i> or <i>5</i>	<i>1</i>	
<i>bcd di 9t</i>	Number of BCD digits	<i>1</i> to <i>4</i>	<i>4</i>	
<i>dP 1 NPt</i>	Remote decimal point	<i>on</i> or <i>OFF</i>	<i>OFF</i>	
<i>1 NPt HOLD</i>	Remote input hold	<i>on</i> or <i>OFF</i>	<i>OFF</i>	
<i>HOLD POL</i>	Input hold polarity	<i>Hi</i> or <i>Lo</i>	<i>Lo</i>	
<i>USER SCALE</i>	User scale	<i>on</i> or <i>OFF</i>	<i>OFF</i>	
<i>CAL 1</i>	First scaling point	n/a	n/a	
<i>CAL 2</i>	Second scaling point	n/a	n/a	
<i>CAL OFFSt</i>	Scaling Offset	n/a	n/a	

<b>Initial display</b>	<b>Meaning of display</b>	<b>Next display</b>	<b>Default Setting</b>	<b>Record Your Settings</b>
<i>bRud</i>	Baud rate	<i>300, 600, 1200, 2400, 4800, 9600, 192 or 38.4</i>	<i>9600</i>	
<i>Prty</i>	Parity	<i>NONE, EVEN or odd</i>	<i>NONE</i>	
<i>OpUt</i>	Communication mode	<i>NONE, d, SP, Cont, POLL or R.buS</i>	<i>Cont</i>	
<i>Rddr</i>	Unit address	<i>0 to 31</i>	<i>0</i>	
<i>SER. TYPE</i>	Serial communications type	<i>NONE, r232 or r485 (1 20 not applicable)</i>	<i>NONE</i>	

**Note:** Functions shown shaded on this table will be displayed, only when those particular options are fitted.

## 6 Scaled inputs

This chapter covers the scaled binary/Gray/BCD code facility of the LD-BC display (note for BCD inputs the **bcdCode** function must be set to 0 if scaling is required). This facility allows the display value for an input to be scaled by a two point scaling i.e. the display does not need to follow normal binary or Gray code values. For example, using the scaling functions it is possible to display half the normal binary value for the inputs present. The functions which allow the scaling facility are:

**USEF SCL E** - this function allows the selection of **on** or **OFF**. If scaled inputs are required then this function must be set to **on**. The display can be reset to normal display values for each input type by setting the function back to **OFF**.

**CAL 1/SCL 1** - first scaling point, see examples which follow.

**CAL 2/SCL 2** - second scaling point, see examples which follow.

**CAL OFSt** - calibration scaling offset value. This function allows an offset value to be added or subtracted from the scaled value. For example if a value of 10 is to be added to all values on the display at the **CAL OFSt** function press the **▲** and **▼** buttons together, the scaled display value for the input will be seen e.g. 150, press the **F** button then use the **▲** button to make the scale value the display value plus 10 e.g. 160. Press the **F** button to accept the change.

The display scaling will operate in parallel, strobed or addressed modes, scaling cannot be used with BCD inputs. The electrical inputs for scaled binary are identical to non scaled binary.

To access any of the scaling function and to follow the examples below it is necessary to enter **CAL** mode, see page 4 for method.

The basic scaling procedure for any input is as follows:

1. Select the input type required e.g. parallel binary
2. Set the **USEF SCL E** function to **on**
3. Place a known input value into the LD-BC and with this input present use **CAL 1/SCL 1** functions to change the scaling for this input as required
4. Change the input to a second known value then use **CAL 2/SCL 2** functions to change the scaling for this input as required

### Example 1 - halving the reading of a Gray code input.

Using inputs of 0 and 6000 decimal arrange the display to show half the normal value.

The Gray code for 6000 decimal is 1110011001000.

The Gray code for 0 is 0.

1. With the Gray code input set at 0 go to the **CAL 1** function and press **▲** & **▼** simultaneously. A display value will be seen.
2. Press the **F** button, the message **SCL 1** will be seen followed by a value. Use the **▲** or **▼** button if required to make this value read 0.
3. Press the **F** button the message **CAL End** followed by **CAL 2** should be seen. Change the input to 1110011001000 (6000 decimal.)
4. Press the **▲** and **▼** buttons together. A display value will be seen.
5. Press the **F** button, the message **SCL 2** will be seen followed by a value. Use the **▲** or **▼** button if required to make this value read 3000.
6. Press the **F** button the message **CAL End** followed by the next function will be seen. Press and release the **F** button until the message **FUNC End** is seen and the display moves back to normal display mode. The readings viewed should now be half the normal Gray code values.

### Example 2 - altering both the zero and span of a Gray code input.

Set the display to read 0 for an input of 3000 and to read 3000 for an input of 6000. Note alternatively the **CAL OFSt** function could be used to achieve the same result.

The Gray code for 6000 decimal is 1110011001000.

The Gray code for 4000 decimal is 100001110000.

The Gray code for 3000 decimal is 111001100100.

1. Set the input to 111001100100 (3000 decimal) then go to the **CAL 1** function and press **▲** & **▼** simultaneously. A display value will be seen.

2. Press the **F** button, the message **SCL 1** will be seen followed by a value. Use the **▲** or **▼** button if required to make this value read 0.
3. Press the **F** button the message **CAL End** followed by **CAL 2** should be seen. Change the input to 1110011001000 (6000 decimal.)
4. Press the **▲** and **▼** buttons together. A display value will be seen.
5. Press the **F** button, the message **SCL 2** will be seen followed by a value. Use the **▲** or **▼** button if required to make this value read 3000.
6. Press the **F** button the message **CAL End** followed by the next function will be seen. Press and release the **F** button until the message **FUNC End** is seen and the display moves back to normal display mode. The readings viewed should now show 0 for an input of 3000 and 3000 for an input of 6000 with the display being linear in between e.g. an input of 4000 should now be displayed as 1000.

## 7 Weighted digital input operation & electrical connections

This chapter describes the special weighted digital input mode available on the LD-BC. To operate in this mode the **SEt I nPt** function must be set to **d, nP**.

The weighted digital input mode allows up to 8 inputs to be given weighted values, these weighted values are added together for each active input. The added values will be displayed and can be retransmitted if an analog or serial retransmission option is fitted.

The functions which control this mode are **d, nP** which allows the number of digital inputs required to be set from 1 to 8 and **d, 1, d, 2, d, 3** etc. which allows the weighting for each input to be set. The weighting value can be set to any display value.

**Example** - Four weighted inputs are to be used with the weighted values to be added & displayed. The display is to have two decimal points and each weighted input in turn is to be given a value of 1.00, 3.00, 5.00 and 10.00. The input signals are to be from a switch inputs with a short circuit to ground being the active signal i.e. active low operation. The main settings required for this example are:

Function	Setting	Description
<b>dCPt</b>	<b>0.02</b>	Sets decimal point to 2 places
<b>d, nP</b>	<b>4</b>	Sets number of weighted inputs to 4
<b>d, 1</b>	<b>1.00</b>	Sets first input weighting to 1.00
<b>d, 2</b>	<b>3.00</b>	Sets second input weighting to 3.00
<b>d, 3</b>	<b>5.00</b>	Sets third input weighting to 5.00
<b>d, 4</b>	<b>10.00</b>	Sets fourth input weighting to 10.00
<b>SEt I nPt</b>	<b>d, nP</b>	Sets input type to weighted digital input
<b>dRtR PDL</b>	<b>Lo</b>	Sets input type to active low operation

The result of these inputs are shown in the table below

Input 1 state	Input 2 state	Input 3 state	Input 4 state	Display
Inactive	Inactive	Inactive	Inactive	0.00
<b>Active</b>	Inactive	Inactive	Inactive	1.00
Inactive	<b>Active</b>	Inactive	Inactive	3.00
<b>Active</b>	<b>Active</b>	Inactive	Inactive	4.00
Inactive	Inactive	<b>Active</b>	Inactive	5.00
<b>Active</b>	Inactive	<b>Active</b>	Inactive	6.00
Inactive	<b>Active</b>	<b>Active</b>	Inactive	8.00
<b>Active</b>	<b>Active</b>	<b>Active</b>	Inactive	9.00
Inactive	Inactive	Inactive	<b>Active</b>	10.00
<b>Active</b>	Inactive	Inactive	<b>Active</b>	11.00
Inactive	<b>Active</b>	Inactive	<b>Active</b>	13.00
<b>Active</b>	<b>Active</b>	Inactive	<b>Active</b>	14.00
Inactive	Inactive	<b>Active</b>	<b>Active</b>	15.00
<b>Active</b>	Inactive	<b>Active</b>	<b>Active</b>	16.00
Inactive	<b>Active</b>	<b>Active</b>	<b>Active</b>	18.00
<b>Active</b>	<b>Active</b>	<b>Active</b>	<b>Active</b>	19.00

The electrical connections for weighted digital inputs are as follows:.

# WEIGHTED DIGITAL INPUT

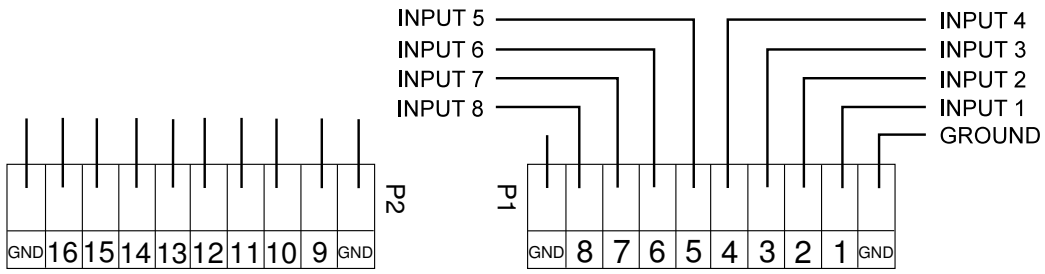

Input circuit weighted input connection  
 Note all GND terminals on connectors P1 & P2 are common.

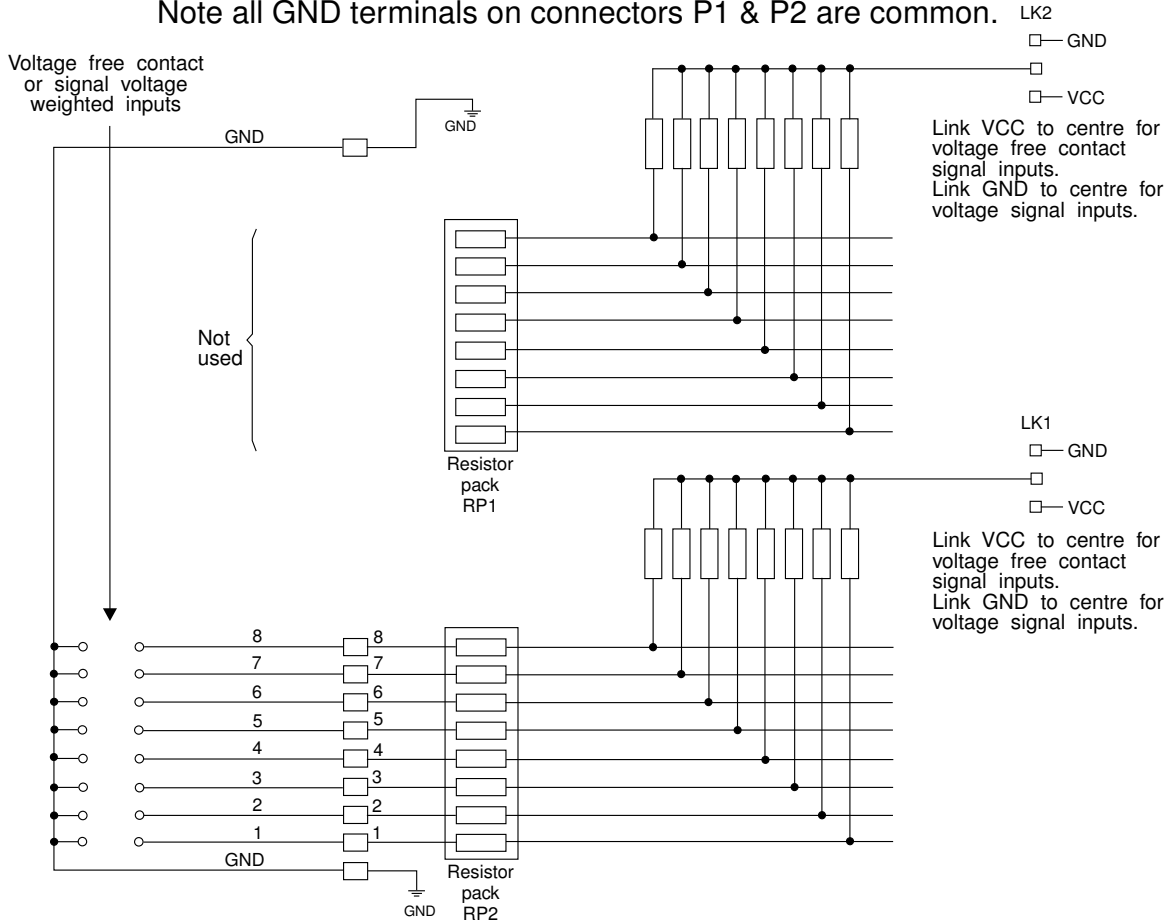

## Example

For weighted digital input the **SELE: NP** function must be set to **d: NP**.

For 4 digital inputs the **d: NP** function is set to 4.

If the input weights are to be 5, 50, 100 & 200

then **d: 1** is set to 5, **d: 2** is set to 50, **d: 3** is set to 100 & **d: 4** is set to 200.

If input 1 is activated 5 is added to the display.

If input 2 is activated 50 is added to the display.

If input 3 is activated 100 is added to the display.

If input 4 is activated 200 is added to the display.

e.g. for an input of 1010 the display will show a value of 250.

---

## 8 RS232/RS485 Commands

---

### RS232/485 Operation and Commands

The RS232/485 interface is user selectable. The **d, SP**, **Cont** and **POLL** operation modes are described below, see "Explanation of functions" chapter for descriptions of other modes:-

**d, SP** - Image Display Mode:

In image display mode the display value is sent via RS232/485 as raw data in the following format:

<ESC> IXYYYY

Where: <ESC> is the ESCAPE character (27 Dec, 1B Hex)

I is the character 'I' (73 Dec, 49 Hex)

X is the number of image bytes in ASCII (31 to 38 Hex)

YYYY is the raw 8 bit display data.

This information is output every display update (approx. 4 times per second - depending upon baud rate). The number of image bytes sent depends on the number of display digits present.

The most common usage would be to provide output for a large digit display for wide area viewing which just mimics the smaller display on the measuring instrument. The large digit displays automatically detect the image mode data and display the correct value accordingly. The data is in seven segment display image i.e. Bit 0 is segment A, Bit 1 is segment B, Bit 7 is decimal point etc.

### **Cont** - Continuous Transmit Mode (ASCII):

In this mode the display value is continually sent via the RS232/485 interface every display update (approx. 4 times per second depending on the baud rate). The format for this is as follows:-

<STX>XYYYY<CR>

Where:<STX> is start of text character (2 Dec, 02 Hex)

X SPACE (32 Dec, 20 Hex) for a positive value.

X '-' (45 Dec, 2D Hex) for a negative value.

YYYY is the display value in ASCII (length depends on number of display digits).

<CR> is a Carriage Return (13 Dec, 0D Hex)

e.g.: If the display is showing 123456 then the instrument will send  
'02 20 31 32 33 34 35 36 0D' (HEX) to the host.

### **POLL** - Host Controlled Transmit Mode (ASCII):

This mode requires a host computer or PLC to poll the instrument to obtain display or other information or reset various setpoint parameters. The format for the host command is as follows:-

<STX>CA<CR> (Standard read etc.)

<STX>CA<CR>N<CR>YYYY (Set Value Command)

Where: <STX> is Start of Text Character (2 Dec, 02 Hex)

C is the command character (see list below)

A is the unit address (Range: 32 to 63 Dec,  
20 to 3F Hex - address is offset by 32 Dec, 20 Hex)

<CR> is Carriage Return (13 Dec, 0D Hex)

N is the setpoint number in ASCII

e.g.: 31 Hex would be alarm 1 etc.

X SPACE for positive and '-' for negative

YYYY is the setpoint value in ASCII

The **POLL** commands available and instrument responses are as follows:

**Transmit Primary Display Value:** <STX>PA<CR>

Instructs unit to return the primary display value. The primary value is the normal display reading. Format of returned data is:-

<ACK>PAXYYYY<CR>

Where: <ACK> is Acknowledge (6 Dec, 06 Hex)

P echo command received 'P' (80 Dec, 50 Hex)

A is the responding unit's address

X SPACE for positive and '-' for negative

YYYY is the display value in ASCII

<CR> is a Carriage Return (13 Dec, 0D Hex)

The number of display characters returned depends on the number of display digits present. If the decimal point is non zero then it will be sent in the appropriate place as '.' (46 Dec, 2E Hex).

**Read Low Alarm Setpoint:** <STX>LA<CR>N<CR>

Instructs unit to return value of low alarm setpoint. Format of returned data is:

<ACK>LANXXXXX<CR>

Where: <ACK> is Acknowledge (6 Dec, 06 Hex)

L echo command received 'L' (76 Dec, 4C Hex)

A is the responding unit's address

N is the setpoint number in ASCII

e.g.: 31 Hex would be alarm 1 etc.

X is SPACE for positive and '-' for negative

YYYY is the setpoint value in ASCII

<CR> is a Carriage Return (13 Dec, 0D Hex)

If setpoint number specified is not present the return string will have the setpoint number set to zero (i.e.: <ACK>LA0).

**Read High Alarm Setpoint:** <STX>HA<CR>N<CR>

Instructs unit to return value of high alarm setpoint. Format of returned data is:

<ACK>HANXXXXX<CR>

Where: <ACK> is Acknowledge (6 Dec, 06 Hex)

H echo command received 'H' (72 Dec, 48 Hex)

A is the responding unit's address

N is the setpoint number in ASCII

e.g.: 31 Hex would be alarm 1 etc.

X is SPACE for positive and '-' for negative

YYYY is the setpoint value in ASCII

<CR> is a Carriage Return (13 Dec, 0D Hex)

If setpoint number specified is not present the return string will have the setpoint number set to zero (i.e.: <ACK>HA0).

**Set Low Alarm Setpoint:** <STX>IA<CR>N<CR>XXXXX<CR>

Instructs unit to change value of low alarm setpoint. Format of returned data is:-

<ACK>IANXXXXX<CR>

Where: <ACK> is Acknowledge (6 Dec, 06 Hex)

I echo command received 'I' (108 Dec, 6C Hex)

A is the responding unit's address

N is the setpoint number in ASCII

e.g.: 31 Hex would be alarm 1 etc.

X is SPACE for positive and '-' for negative

YYYY is the setpoint value in ASCII

<CR> is a Carriage Return (13 Dec, 0D Hex)

If setpoint number specified is not present the return string will have the setpoint number set to zero (i.e.: <ACK>IA0XXXXX).

**Set High Alarm Setpoint:** <STX>hA<CR>N<CR>XXXXX<CR>

Instructs unit to change value of high alarm setpoint. Format of returned data is:-

<ACK>hANXXXXX<CR>

Where: <ACK> is Acknowledge (6 Dec, 06 Hex)

h echo command received 'h' (104 Dec, 68 Hex)

A is the responding unit's address

N is the setpoint number in ASCII

e.g.: 31 Hex would be alarm 1 etc.

X is SPACE for positive and '-' for negative

YYYY is the setpoint value in ASCII

<CR> is a Carriage Return (13 Dec, 0D Hex)

If setpoint number specified is not present the return string will have the setpoint number set to zero (i.e.: <ACK>hA0XXXXX).

### **Transmit Instrument Model and Version: <STX>IA<CR>**

Instructs unit to return the model and version number of the instrument. Format of returned data is:-

<ACK>IACCX.X<CR>

Where: <ACK> is Acknowledge (6 Dec, 06 Hex)  
I is echo command received 'I' (73 Dec, 49 Hex)  
A is the responding unit's address  
CC a 2 character model identifier (e.g.: **bc** )  
X.X is the version number (e.g.: '0.1')  
<CR> is a Carriage Return (13 Dec, 0D Hex)

### **Invalid Command**

If the command received from the host is not valid then the unit will return the following:-

<ACK>?A<CR>

Where: <ACK> is Acknowledge (6 Dec, 06 Hex)  
? is the character '?' (63 Dec, 3F Hex)  
A is the responding unit's address  
<CR> is a Carriage Return (13 Dec, 0D Hex)

If the address received from the host does not match the units address then the unit will not respond at all.

Other commands may be added to suit the particular configuration of each instrument. Value read commands will have the same format as the Transmit Primary Value command. Set Value commands will have the same format as the Set Low Alarm Setpoint command etc.

### **Host Timing Requirements for RS485 Operation:**

RS485 operation requires the host to switch the RS485 transceiver to transmit before a command is sent. The instrument is capable of replying after 1 to 2 milliseconds. Therefore the host should switch the RS485 transceiver back to receive mode within 0.5 milliseconds after the last character of the command has been sent to ensure correct operation.

ASCII Char.	Dec	Hex	ASCII Char.	Dec	Hex
NUL (^@)	000	00	@	64	40
SOH (^A)	001	01	A	65	41
STX (^B)	002	02	B	66	42
ETX (^C)	003	03	C	67	43
EOT (^D)	004	04	D	68	44
ENQ (^E)	005	05	E	69	45
ACK (^F)	006	06	F	70	46
BEL (^G)	007	07	G	71	47
BS (^H)	008	08	H	72	48
HT (^I)	009	09	I	73	49
LF (^J)	010	0A	J	74	4A
VT (^K)	011	0B	K	75	4B
FF (^L)	012	0C	L	76	4C
CR (^M)	013	0D	M	77	4D
SO (^N)	014	0E	N	78	4E
SI (^O)	015	0F	O	79	4F
DLE (^P)	016	10	P	80	50
DC1 (^Q)	017	11	Q	81	51
DC2 (^R)	018	12	R	82	52
DC3 (^S)	019	13	S	83	53
DC4 (^T)	020	14	T	84	54
NAK (^U)	021	15	U	85	55
SYN (^V)	022	16	V	86	56
ETB (^W)	023	17	W	87	57
CAN (^X)	024	18	X	88	58
EM (^Y)	025	19	Y	89	59
SUB (^Z)	026	1A	Z	90	5A
ESC (^[)	027	1B	[	91	5B
FS (^\\)	028	1C	\\	92	5C
GS (^])	029	1D	]	93	5D
RS (^^^)	030	1E	^	94	5E
US (^_)	031	1F	_	95	5F
SP ( )	032	20	'	96	60
!	033	21	a	97	61
“	034	22	b	98	62

#	035	23	c	99	63
\$	036	24	d	100	64
%	037	25	e	101	65
&	038	26	f	102	66
'	039	27	g	103	67
(	040	28	h	104	68
)	041	29		105	69
*	042	2A	j	106	6A
+	043	2B	k	107	6B
,	044	2C	l	108	6C
-	045	2D	m	109	6D
.	046	2E	n	110	6E
/	047	2F	o	111	6F
0	048	30	p	112	70
1	049	31	q	113	71
2	050	32	r	114	72
3	051	33	s	115	73
4	052	34	t	116	74
5	053	35	u	117	75
6	054	36	v	118	76
7	055	37	w	119	77
8	056	38	x	120	78
9	057	39	y	121	79
:	058	3A	z	122	7A
;	059	3B	{	123	7B
<	060	3C		124	7C
=	061	3D	}	125	7D
>	062	3E	~	126	7E
?	063	3F	DEL	127	7F

---

## 9 Specifications

---

### 9.1 Technical Specifications

Input Data:	Up to 16 bit BCD, binary or Gray code, parallel, addressed or strobed or weighted digital input (up to 8 inputs). For BCD inputs four of the 16 input bits can be assigned for use as remote decimal point input and display hold input if required.
Input Types	5V, 12V to 24V or 48V DC, contact closure or open collector (factory configured).
Input Logic:	Selectable active high or low.
Decimal Point:	User programmable or remote selectable for BCD inputs.
Microprocessor:	MC68HC11 CMOS.
Ambient Temperature:	-10 to 60°C.
Humidity:	5 to 95% non condensing.
Power Supply:	100 & 200mm displays: AC 240V/110V 50/60Hz multi tap user selectable or AC 24/32/42/48 V 50/60Hz multi tap user selectable or DC 12 to 48V isolated or DC 24V ( $\pm 10\%$ ) non isolated: 57mm 4 digit displays: 240VAC, 110VAC 50/60Hz, 12 to 48VDC isolated or 24VDC non isolated. Supply type is factory configured
Power Consumption:	AC supply 15 VA max, DC supply, consult supplier (depends on display type & options fitted).

### 9.2 Options

Alarm relays:	1 or 2 alarm relays (binary, Gray code, whole number BCD ( <b>bc d C O d E</b> = <b>0</b> ) and weighted digital input only).
Serial communications:	Non isolated RS232 or RS485 (factory configured) (binary, Gray code, whole number BCD ( <b>bc d C O d E</b> = <b>0</b> ) and weighted digital input only). Isolated RS485 is also available as an option.

### 9.3 Physical Characteristics

Models LD-BC-X-100E4 100mm 4 digit electromagnetic	Case size (mm) = 450 x 250 x 155 Weight: = 8.5 kgs Mounting hole locations - see "Mechanical Installation" chapter
Models LD-BC-X-100E5 100mm 5 digit electromagnetic	Case size (mm) = 520 x 250 x 155 Weight: = 9.5 kgs Mounting hole locations - see "Mechanical Installation" chapter
Models LD-BC-X-100E6 100mm 6 digit electromagnetic	Case size (mm) = 650 x 250 x 155 Weight: = 10.5 kgs Mounting hole locations - see "Mechanical Installation" chapter
Model LD-BC-X-57R4 57mm 4 digit LED	Case size (mm) = 255 x 145 x 125 Weight: = 1.3 kgs Mounting hole locations - see "Mechanical Installation" chapter
Model LD-BC-X-100R4 100mm 4 digit LED	Case size (mm) = 450 x 250 x 155 Weight: = 8.5 kg Mounting hole locations (mm) - see "Mechanical Installation" chapter
Model LD-BC-X-100R6 100mm 6 digit LED	Case size (mm) = 650 x 250 x 155 Weight: = 10.5 kg Mounting hole locations - see "Mechanical Installation" chapter
Model LD-BC-X-200R4 200mm 4 digit LED	Case size (mm) = 850 x 360 x 130 Weight: = 12 kg Mounting hole locations - see "Mechanical Installation" chapter

The product supplied with this manual is guaranteed against faulty workmanship for a period of 2 years from the date of dispatch.

Our obligation assumed under this guarantee is limited to the replacement of parts which, by our examination, are proved to be defective and have not been misused, carelessly handled, defaced or damaged due to incorrect installation. This guarantee is VOID where the unit has been opened, tampered with or if repairs have been made or attempted by anyone except an authorised representative of the manufacturing company.

Products for attention under guarantee (unless otherwise agreed) **must be returned to the manufacturer freight paid** and, if accepted for free repair, will be returned to the customers address in Australia free of charge.

When returning the product for service or repair a full description of the fault and the mode of operation used when the product failed must be given.

In any event the manufacturer has no other obligation or liability beyond replacement or repair of this product.

Modifications may be made to any existing or future models of the unit as it may deem necessary without incurring any obligation to incorporate such modifications in units previously sold or to which this guarantee may relate.

**This document is the property of  
the instrument manufacturer  
and may not be reproduced in whole or part without the  
written consent of the manufacturer.**

**This product is designed and manufactured in Australia.**