

LD4-RS
Special Version 57mm 4 Digit
Large Digit Remote Display
XT4-WT Load Cell Interface
Operation and Instruction Manual

Table of Contents

Introduction	3
Mechanical Installation	4
Electrical Installation	5
Power supply connections	6
Relay connections	6
Input/output connectors	7
Terminating resistor for RS485 communications	7
Remote input connector	7
Explanation of Functions	8
Error Messages.	18
Function Table	19
Batch operation	21
Calibration	23
Specifications	27
Technical Specifications	27
Physical characteristics.	27
Guarantee and Service	28

1 Introduction

This manual contains information for the installation and operation of the special version model LD4 57mm 4 digit display used in conjunction with the XT4-WT load cell interface. This manual covers the electrical connections and software functions seen when connecting the display to the XT4-WT. For use of the XT4-WT with a computer consult the XT4-WT manual.

The LD4 display provides an alternative to a computer for the setup, calibration and display of input 1 connection to the XT4. Load cell input 1 is the only XT4-WT input which can be viewed by this LD4 display.

Communication between the LD4 and the XT4 is via RS485 serial communications. The “Unit Address” function in the XT4-WT must match address set at the **Addr** function in the LD4. Changes to the “Unit Address” function will require connecting the XT4-WT to a computer since changing the **Addr** function in the LD4 does not change the “Unit Address” function. In multiple XT4-WT systems changing the **Addr** address allows the LD4 to choose which XT4-WT it communicates with.

Two standard inbuilt relays are provided for alarm/control functions, a supply of 18VDC (unregulated) or 5V (regulated), 20mA max. is also provided on AC powered models.

Unless otherwise specified at the time of order, your LD4 has been factory set to a standard configuration, see the “Function Table” chapter for a list of default settings. Like all other LD4 series instruments the configuration and calibration is easily changed by the user.

The LD4 series of Large Digit Display Monitors are designed for high reliability in industrial applications. The high brightness LED display provides good visibility, even in areas with high ambient light levels.

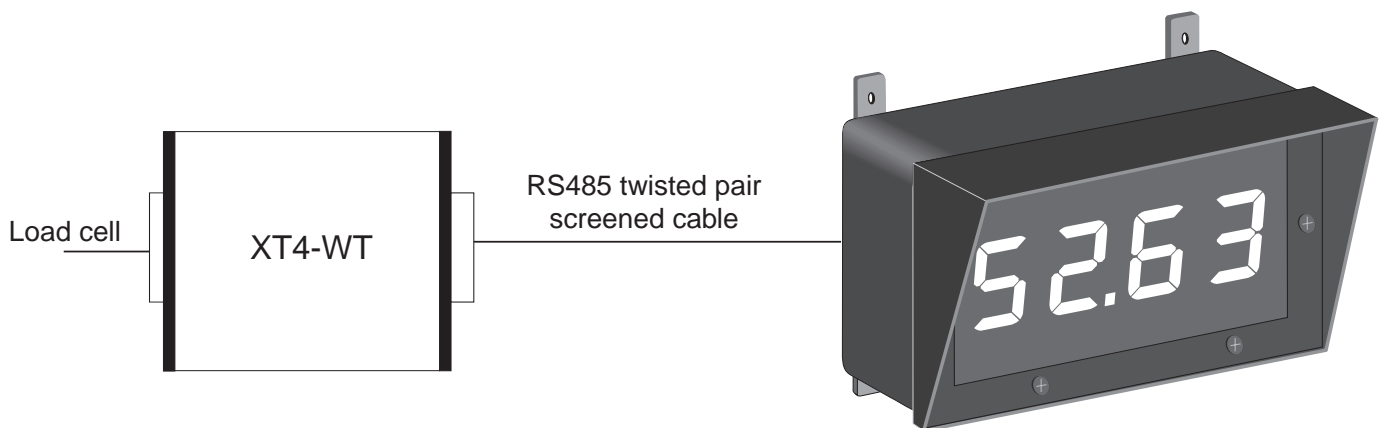

2 Mechanical Installation

The instrument is designed be wall mounted. Note which model is to be installed then carefully measure and drill holes, as shown below.

All sizes are in mm. Mounting hole diameters are 6.5mm.

Note: the LD4 range housings, other than the 57mm 4 digit, are currently undergoing redesign please check the physical size of the enclosure as the sizes given below may no longer apply.

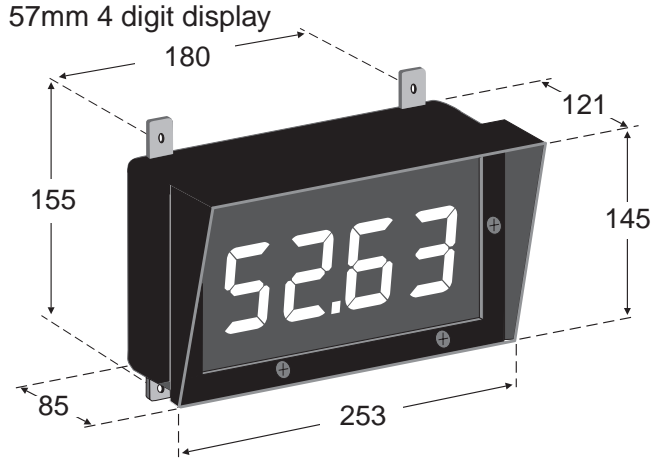

An optional panel mount kit is available for the 57mm type display. Panel cut out size is 240 x 130mm (-0.0mm/+0.5mm)

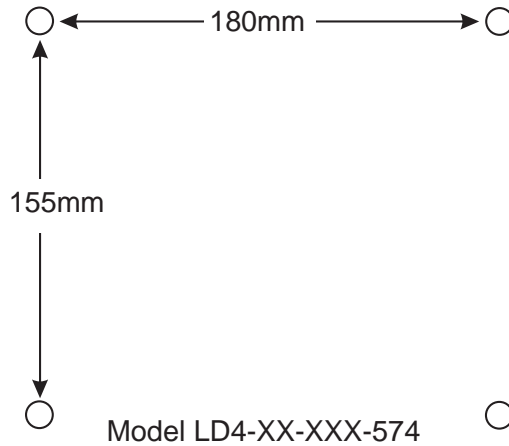

3 Electrical Installation

The LD4 instrument is designed for continuous operation and no power switch is fitted to the unit. It is recommended that an external switch and fuse be provided to allow the unit to be removed for servicing.

The terminal blocks, which are the plug in type for ease of installation, allow for wires of up to 2.5mm² for power supply and relay connections, 1.5mm² for input connections, to be fitted. Connect the wires to the appropriate terminals as indicated below. Refer to other details provided in this manual to confirm proper selection of voltage, polarity and input type before applying power to the instrument. When power is applied the instrument will cycle through a display sequence, indicating the software version and other status information, this indicates that the instrument is functioning.

MAIN CIRCUIT BOARD LAYOUT (PARTIAL VIEW)

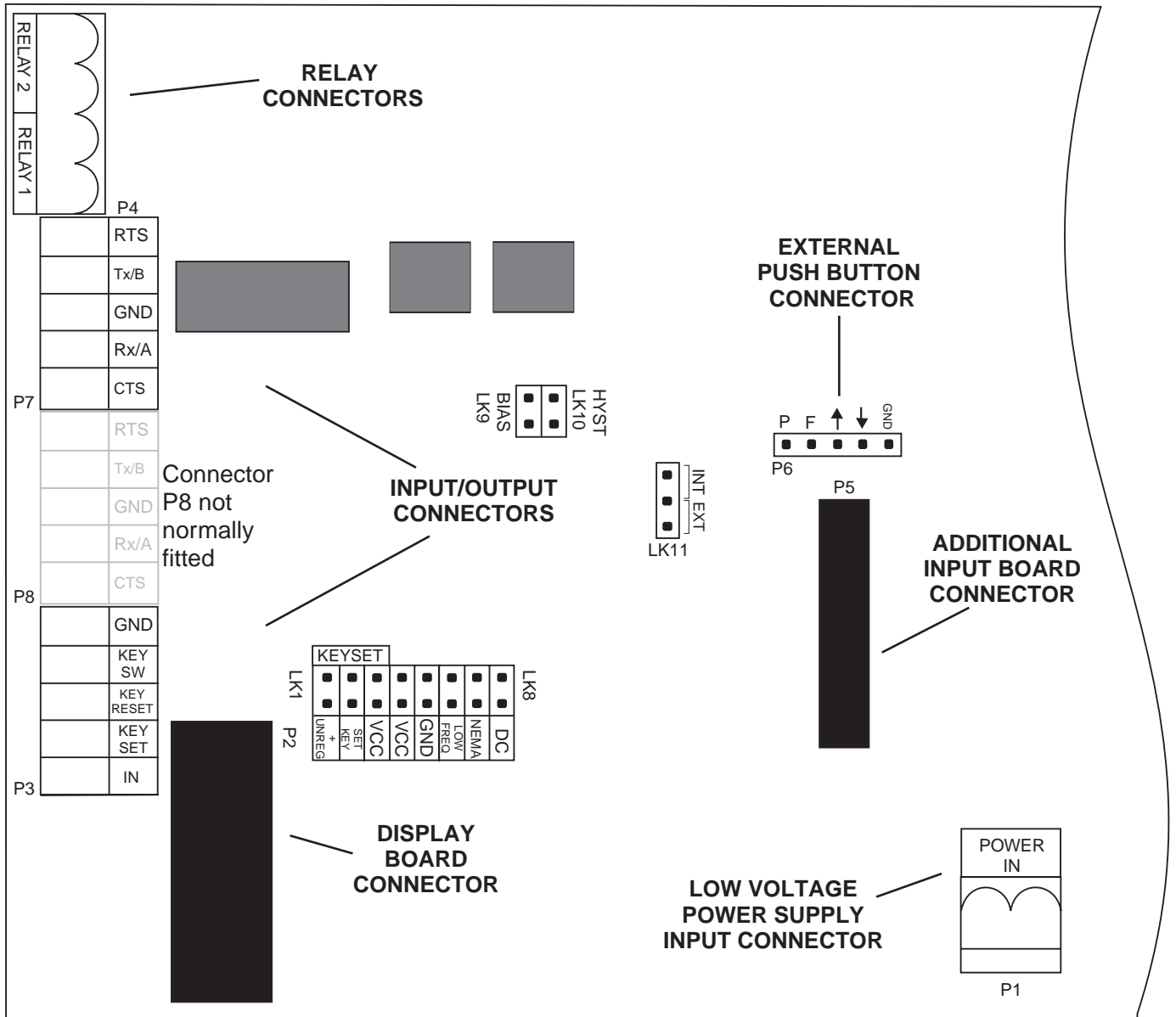

3.1 Power supply connections

Mains power connections (240VAC or 110VAC) are via a plug in terminal with screw connections.

The transformer low voltage AC output goes to the power supply connector P1 on the main circuit board via the lead supplied.

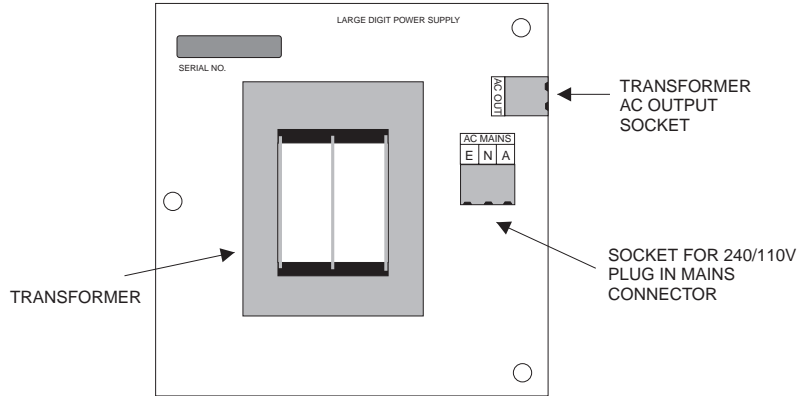

Non isolated DC supplies (15 to 24V) are connected at the main circuit board power supply connector P1 via the plug in connector terminals. The positive and negative supplies may be connected either way around.

Optional isolated DC supplies use plug in terminals supplied on the power supply board as shown below. The output from the isolated DC supply board connects directly to the main circuit board power supply connector via the plug in connector (P1) terminals.

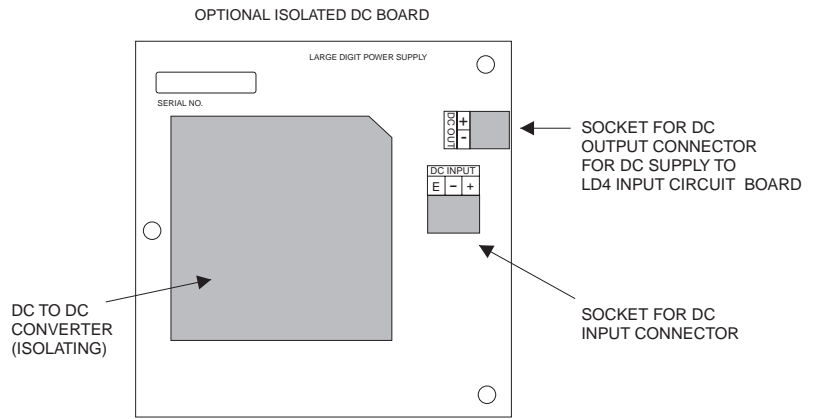

3.2 Relay connections

The LD4 is supplied with two alarm relays as standard with connections on P4. The relays are single pole, single throw types and are rated at 5A, 240VAC into a resistive load. The relay contact is voltage free and may be programmed for normally open or normally closed operation.

3.3 Input/output connectors

The diagram below shows the input/output connectors for the LD4 to XT4 system.

An internal power supply allows the KEY SET input to be used to give a supply output to power the XT4-WT with a load cell of at least 350Ω resistance. This power supply is available on AC powered models.

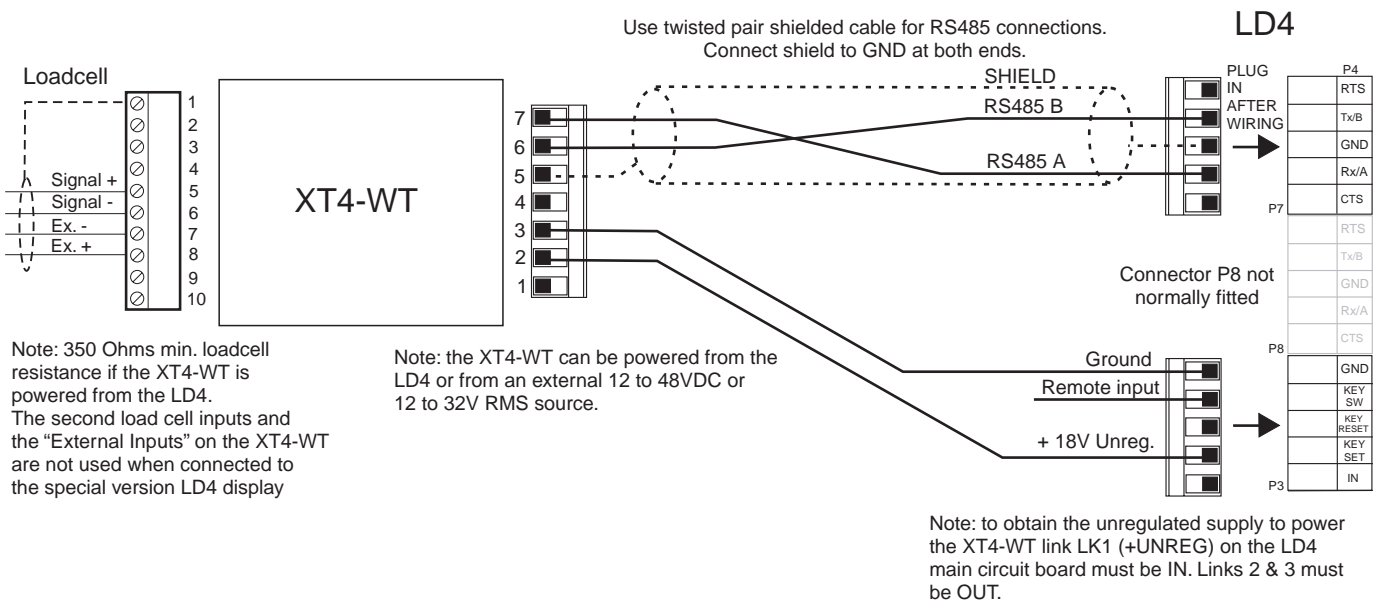

3.4 Terminating resistor for RS485 communications

When RS485 communications is used the first and last units connected on the circuit (or both units if only 2 units are connected) must be fitted with terminating resistors. The terminating resistor must be fitted externally e.g. fitted to the connector across the RS485 A & B terminals. A 100Ω resistor may be used as the terminating resistor.

3.5 Remote input connector

The LD4 has a software function called **REMOTE INPUT** or remote input. Closure of the remote input connector via a switch or relay contact to the GND terminal will cause the selected remote input function to operate. The location of the remote input connector is shown in the diagram above.

4 Explanation of Functions

The LD4 setup and calibration functions are configured through a push button sequence. Two levels of access are provided for setting up and calibrating:-

FUNC mode (simple push button sequence) allows access to commonly used set up functions such as alarm setpoints.

CAL mode (power up sequence plus push button sequence) allows access to all functions including calibration parameters.

The three push buttons located on the main circuit board are used to alter settings. Once **CAL** or **FUNC** mode has been entered you can step through the functions, by pressing and releasing the **F** push button, until the required function is reached. Changes to functions are made by pressing the **▲** or **▼** push button (in some cases both simultaneously) when the required function is reached.

Entering **CAL** Mode

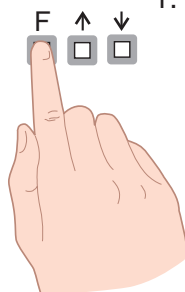

1. Remove power from the instrument and wait 5 seconds . Hold in the **F** button and reapply power. The display will indicate **CAL** as part of the "wake up messages" when the **CAL** message is seen you can release the button. Move to step 2 below.

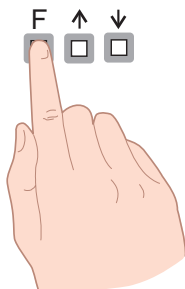

2. When the "wake up" messages have finished and the display has settled down to its normal reading press, then release the **F** button. Move to step 3 below.

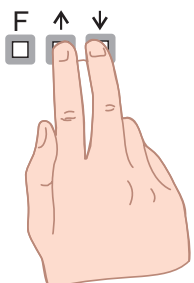

3. Within 2 seconds of releasing the **F** button press, then release the **▲** and **▼** buttons together. The display will now indicate **FUNC** followed by the first function.

Notes: If step 1 above has been completed then the instrument will remain in this **CAL** mode state until power is removed. i.e. there is no need to repeat step 1 when accessing function unless power has been removed.

The instrument should show all 8's on power up e.g. **8.8.8.8**. if the instrument does not reset then these numbers will not be seen. Switch off the instrument and allow a longer time delay before powering up again.

Entering **FUNC** Mode

No special power up procedure is required to enter **FUNC** mode.

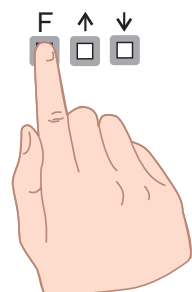

1. When the "wake up" messages have finished and the display has settled down to its normal reading press, then release the **F** button. Move to step 2 below.

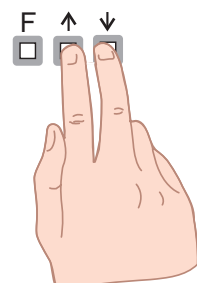

2. Within 2 seconds of releasing the **F** button press, then release the **▲** and **▼** buttons together. The display will now indicate **FUNC** followed by the first function.

The alarm and brightness functions below are accessible via **FUNC** mode.

The LD4 has an easy alarm access facility which allows access to the alarm setpoints simply by pressing the **F** button. The first setpoint will then appear and changes to this setpoint may be made to this setpoint via the **▲** or **▼** buttons. Press the **F** button to accept any changes or to move on to the next setpoint.

The instrument must be set in the manner described below to allow the easy access facility to work:

1. The **F.I NP** function must be set to **SP.AC** or the **ALCS** function must be set to **EASY**.
2. At least one alarm must have a setpoint, nothing will happen if all the alarm setpoints are set to **OFF**.
3. The **SP.AC** function must be set to allow access to the relays required e.g. if set to **R 1-2** then the easy access will work only with alarm relays 1 and 2 even if more relays are fitted.
4. The instrument must be in normal measure mode i.e. if the instrument is powered up so that it is in **CAL** mode then the easy access will not function. If in doubt then remove power from the instrument, wait for a few seconds then apply power again.
5. If the easy access facility is used then the only way to view or alter any other function settings is to power up via **CAL** mode i.e. there is not entry to **FUNC** mode unless the instrument is powered up in **CAL** mode.

R 1Lo (alarm 1 low setpoint)

Displays and sets the low setpoint value for alarm 1 relay. The low alarm setpoint may be disabled by pressing the **▲** and **▼** pushbuttons simultaneously. When the alarm is disabled the display will indicate **OFF**. Use **▲** or **▼** to adjust the setpoint value if required. The alarm will activate when the displayed value is lower than the **R 1Lo** setpoint value. Each relay may be configured with both a low and high setpoint if required, if so the relay will be activated when the display reading moves outside the band set between low and high setpoints.

R 1Hi (alarm 1 high setpoint)

Displays and sets the high setpoint value alarm 1 relay. The high alarm setpoint may be disabled by pressing the **▲** and **▼** pushbuttons simultaneously. When the alarm is disabled the display will indicate **OFF**. Use **▲** or **▼** to adjust the setpoint value if required. The alarm will activate when the displayed value is higher than the **R 1Hi** setpoint value. Each relay may be configured with both a low and high setpoint if required, if so the relay will be activated when the display reading moves outside the band set between low and high setpoints.

R 2Lo (alarm 2 low setpoint)

Displays and sets alarm 2 low setpoint, see **R 1Lo** for further description.

R 2Hi (alarm 2 high setpoint)

Displays and sets alarm 2 high setpoints, see **R 1Hi** for further description.

R 1HY (alarm 1 hysteresis [deadband])

Displays and sets the alarm hysteresis limit and is common for both high and low setpoint values. The hysteresis value may be used to prevent too frequent operation of the setpoint relay when the measured value stays close to the setpoint. Without a hysteresis setting (**R 1HY** set to zero) the alarm will activate when the display value goes above the alarm setpoint (for high alarm) and will reset when the display value falls below the setpoint, this can result in repeated on/off switching of the relay at around the setpoint value. The hysteresis setting operates as follows:

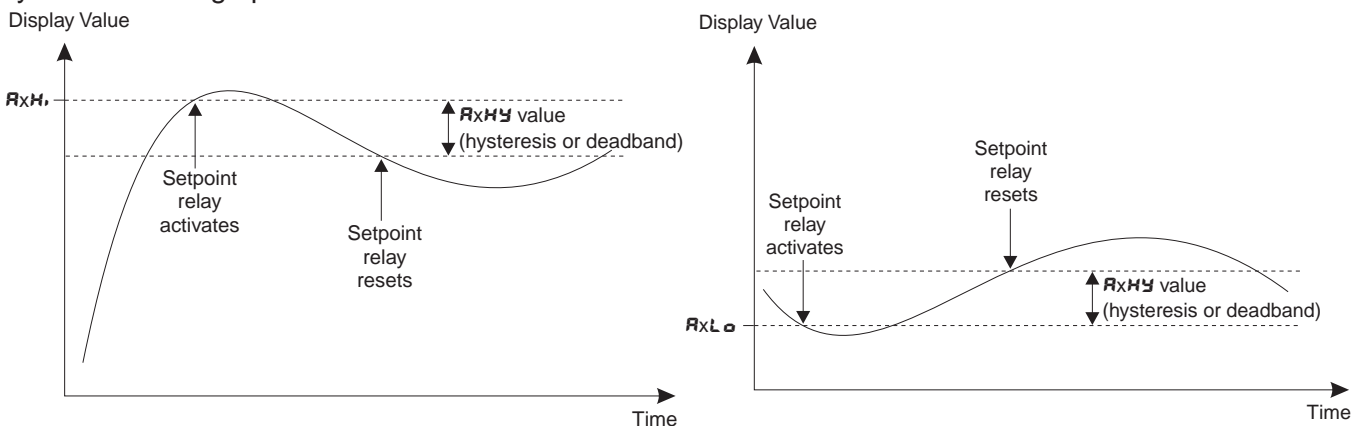

In the high alarm mode, once the alarm is activated the input must fall below the setpoint value minus the hysteresis value to reset the alarm.

e.g. if **R 1H** is set to **50.0** and **R 1HY** is set to **3.0** then the setpoint output relay will activate once the display value goes above **50.0** and will reset when the display value goes below **47.0** (50.0 minus 3.0).

In the low alarm mode, once the alarm is activated the input must rise above the setpoint value plus the hysteresis value to reset the alarm.

e.g. if **R 1LO** is set to **20.0** and **R 1HY** is set to **10.0** then the alarm output relay will activate when the display value falls below **20.0** and will reset when the display value goes above **30.0** (20.0 plus 10.0).

The hysteresis units are expressed in displayed engineering units.

R2HY (alarm 2 hysteresis [deadband])

Displays and sets the alarm hysteresis limit for alarm 2 see **R 1HY** for further description.

R 1TT (alarm 1 trip time)

Displays and sets the alarm trip time and is common for both alarm high and low setpoint values. The trip time is the delay time before the alarm relay will activate, or trip, when an alarm condition is present. The alarm condition must be present continuously for the trip time period before the alarm will trip. This function is useful for preventing an alarm trip due to short non critical deviations from setpoint. The trip time is selectable over **0** to **9999** seconds.

R2TT (alarm 2 trip time)

Displays and sets the alarm trip time for alarm 2 see **R 1TT** for further description.

R 1RT (alarm 1 reset time)

Displays and sets the alarm relay reset time. With the alarm condition is removed the alarm relay will stay in its alarm condition for the time selected as the reset time. The reset time is selectable over **0** to **9999** seconds.

R2RT (alarm 2 reset time)

Displays and sets the alarm relay reset time for alarm 2, see **R 1RT** for further description.

R 1NO or R 1NC (alarm 1 normally open or normally closed)

Displays and sets the setpoint alarm relay action to normally open (de-energised) or normally closed (energised), when no alarm condition is present. A normally closed alarm is often used to provide a power failure alarm indication.

R2NO / R2NC (alarm normally open or normally closed)

Displays and sets the setpoint alarm relay action for alarm 2 see **R 1NO/R 1NC** for further description.

R2.SP, R2.T 1 (relay operation independent setpoint or trailing) - this function will not be seen if both the high and low setpoints are set to **OFF**.

Each alarm may be programmed to operate with an independent setpoint setting or may be linked (or trailing) to operate at a fixed difference to another relay setpoint. The operation is as follows: Alarm 1 (**R1**) is always independent. Alarm 2 (**R2**) may be independent or may be linked to Alarm 1. The operation of each alarm is selectable within the Function Setup Mode by selecting, for example, (Alarm 2) **R2.SP** = Alarm 2 normal setpoint or **R2.T 1** = Alarm 2 trailing Alarm 1. For trailing set points the setpoint value is entered as the difference from the setpoint being trailed. If the trailing setpoint is to operate ahead of the prime setpoint then the value is entered as a positive number and if operating behind the prime setpoint then the value is entered as a negative number. For example, with Alarm 2 set to trail alarm 1, if **R 1H** is set to 1000 and **R2H** is set to 50 then Alarm 1 will trip at 1000 and alarm 2 will trip at 1050 (i.e. 1000 + 50). If Alarm 2 had been set at -50 then alarm 2 would trip at 950 (i.e. 1000 - 50).

b 9 (display brightness)

Displays and sets the digital display brightness. The display brightness is selectable from **1** to **15**, where **1** = lowest intensity and **15** = highest intensity. This function is useful for improving the display readability in dark areas or to reduce the power consumption of the instrument.

dULL (remote input controlled display brightness)

Displays and sets the level for remote input brightness switching, see **F.I NP** function. When the remote input function is set to **dULL** the remote input can be used to switch between the display brightness level set by the **br 9t** function and the display brightness set by the **dULL** function. The display brightness is selectable from **0** to **15**, where **0** = lowest intensity and **15** = highest intensity. This function is useful in reducing glare when the display needs to be viewed in both light and dark ambient light levels.

R 1 F F E E (free fall alarm value for relay 1)

The alarm free fall value is used to provide an offset to the alarm operation. This value can be set anywhere within the measuring range of the instrument and will operate in engineering units e.g. kilograms, tonnes etc. In most applications this function will be used to force the alarm to operate at a given measured quantity prior to the actual alarm setting.

In most applications the **R 1 F F E E** function will be used in conjunction with a “high” alarm setting such as **R 1 H**, to force the alarm relay to operate at a given measured quantity prior to the actual alarm setting. This function can be used to prevent any overflowing due to product which was in “free fall” when the alarm relay operated.

Applications include filling containers via a chute, auger or conveyor belt in which shutting off the filling process once the desired weight is reached will result in some overflowing due to the free fall product. The free fall value can be found by comparing the required product weight to the final weight.

For example a series of containers is to be filled with 40.0kg of product, **R 1 H**, is set to **40.0** and this relay activation is used to stop the filling process. It is found that due to free fall product the average weight of the filled containers is actually 41.7kg. i.e. 1.7kg of product continues to fill the container after the alarm relay used to stop the filling process is activated. As an alternative to subtracting 1.7kg from the **R 1 H**, setting we can use the free fall setting **R 1 F F** of 1.7 to ensure that alarm 1 relay operates 1.7kg prior to the desired weight.

The table below illustrates the action of the free fall alarm with both high and low alarm relay settings.

		Alarm relay activates at display reading of:	With a hysteresis of 5 (RxHy) alarm resets at:
R 1 F F = 10	R 1 H = 100	90 or above	85 or below
R 1 F F = 10	R 1 Lo = 50	40 or below	45 or above
R 1 F F = -10	R 1 H = 100	110 or above	105 or below
R 1 F F = -10	R 1 Lo = 50	60 or below	65 or above

R 2 F F E E (free fall alarm value for relay 2)

See **R 1 F F E E** above.

The functions which follow are accessible via **CAL** mode only or if the **ACC5** function is set to **ALL**.

P.5E t (preset value)

Displays and sets the preset value to be used with the remote inputs or **P** button function. When the **P.5E t** function is used the preset value will be set as the display value when the appropriate remote input or **P** button is activated. This setting will cause an offset in the calibration scaling. Once activated the preset value will be retained even if power is removed. Example: The LD4 is calibrated to read from **0** to **1000** for a 0 to 1000kg load. If a **P.5E t** value of 50 is entered via remote input when the display reads **0** then the LD4 will read from **50** to **1050** for the same 0 to 1000kg load.

CL.no (cell or channel number selection)

Selects one of the two possible calibration settings (**CAL. 1** or **CAL.2**). This function allows the instrument to be calibrated to two different load cells and hold the calibration values in memory. Alternatively two different calibration scaling values may be entered for a single cell. The user may select the load cell to be used via this function, via the **P** button (if fitted) or via a remote input (see **CAL.5** function under the **F.I NP** function). To scale any of these independent calibration memories you may use any of the methods described in the “Calibration” chapter. Simply select the required cell number then scale using whichever calibration method best suits the application. If a remote input or **P** button is used to select the channel then do not use the **CL.no** function to select the channel i.e. only use one method of selecting the channel.

In addition to different scaling the two channels can be set to operate from different decimal point (**dCP t**), sample rate (**F R E E**), mV/V range (**F R S E**), lineariser point (**L. n P t S**), low & high overrange (**Lo**

d: SP & H: 9H d: SP) and display warning type (**d: SP**) settings. If using this function in conjunction with the remote inputs or **P** button functions then the peak hold, display hold, peak and valley memory, zero, remote input calibrate, and serial print output functions will operate individually for each channel, the tare command will tare both channels simultaneously. Other remote input and **P** button functions are not intended for use with the channel selection function.

d r n d (display rounding)

Displays and sets the display rounding value. This value may be set to 0 - 5000 displayed units. Display rounding is useful for reducing the instrument resolution without loss of accuracy, in applications where it is undesirable to display to a fine tolerance. (example if set to **10** the display indication will change in multiples of 10 only).

d C P t (decimal point selection)

Displays and sets the decimal point. By pressing the **▲** or **▼** pushbuttons the decimal point position may be set. The display will indicate as follows: **0** (no decimal point), **0. 1** (1 decimal place), **0.02** (2 decimal places) or **0.003** (3 decimal places).

F L t r (digital filter)

Displays and sets the digital filter value. Digital filtering is used for reducing susceptibility to short term interference. The digital filter range is selectable from 0 to 8, where 0 = none and 8 = most filtering. A typical value for the digital filter would be 3. Use **▲** or **▼** to alter if required. Note that at higher filter values the display update time will be increased.

r R t E (sample rate for ADC)

Displays and sets the ADC sample from 1 to 5 samples per second and is selected in steps as follows:
1.2 or **5**

r n g e (full scale mV per V output of transducer)

Displays and sets the full scale mV/V range to suit the transducer useable range and is selected in steps as follows:

2.0, 4.0, 8.0 or **16.0**

Choose the value equal to or the next higher value to the mV/V output of the transducer. This selection sets the input range for the A/D converter, if too low a range is selected a " - - - " error message will be seen on the display. Note the mV/V range setting is a nominal figure only.

r i n p (remote input 1)

r i n p (remote input function)

See "Electrical Installation" the location of the remote input connector. When these pins are short circuited, via a pushbutton or keyswitch the instrument will perform the selected remote input function. A message will flash to indicate which function has been selected when the remote input pins are short circuited. The remote input functions are as follows:

n o n e (None) - this function is selected when none of the special functions are required.

P H L d (Peak Hold) - this function displays and holds the peak reading, when the contact input is closed i.e. the maximum value from the time of contact closure. When the contact is open the display indicates the live reading.

d H L d (Display Hold) - the display hold function is similar to peak hold, except that the held reading is the value displayed when the switch contact is closed.

H (Peak Memory) - the peak memory (max) is displayed when the pushbutton contact is closed momentarily i.e. the maximum display value since the last reset. The display is returned to the normal display after 20 seconds. To reset the peak memory the button must be held closed for approx. 2 seconds. Note: the **H** function will be reset 5 seconds after instrument switch on i.e. the **H** readings will only start to be stored once 5 seconds have elapsed.

L o (Valley Memory) - the valley memory (min) operates in a similar way to the peak memory but shows the lowest display value since last reset. To reset the valley memory the button must be held closed for approx. 2 seconds. Note: the **L o** function will be reset 5 seconds after instrument switch on i.e. the **L o** readings will only start to be stored once 5 seconds have elapsed.

H, L o (Peak Memory/Valley Memory) - the display may be toggled between peak and valley memory indications. To reset the peak or valley memory the button must be held closed for approx. 2 seconds whilst the value to be reset is being viewed.

TARE (Pushbutton Tare) - when the remote pushbutton is closed for 2 to 3 seconds the current input value is tared off. The switch input for this function is usually a momentary action pushbutton switch. Once the display has been tared the "live" display will be interrupted every few seconds by the message **NETT** to indicate that the reading has been tared and the nett reading is being displayed. Further operation of the pushbutton will cause the display to toggle between gross reading (the display will indicate this by flashing **GROSS** periodically) and nett reading (indicated by **NETT**). Removing power from the instrument will cause the value tared to be lost so another tare operation may be needed.

ZERO (Pushbutton Zero) - allows the load cell system display to be set to zero via momentary operation of the pushbutton. This zero value will be retained even if the power is removed. If the zero operation were to cause the zero to shift beyond the **ZERO RANGE** function limits the preset will be aborted and a **ZERO RANGE Err** message will be seen.

SP.AC (Setpoint Access Only) - allows access to alarm set points only, no other functions, when key switch is open. Allows full access with the key switch/remote input closed. The switch input for this function is usually a key switch. Note: If more than one remote input is set to **SP.AC** then all of those inputs must be closed to allow full access.

no.AC (No Program Access) - inhibits access to functions via pushbuttons and front panel keypads. The remote input requires a contact closure to allow access to functions. The switch input for this function is usually a key switch. If more than one remote input is set to **no.AC** then all of those inputs must be closed to allow access.

CAL.S (Select calibration - not fitted on all software versions) - when the external input is open the calibration selected in function mode will be used. When the external input is closed the next calibration set will be used. e.g. if **CAL. 1** is selected under the **CL.no** function then closing the switch will cause the next calibration (**CAL.2**) to be used. This function may be used to select different load cells, different rigging arrangements etc. This may also be used to change measuring units. e.g. the unit may be calibrated in kg on **CAL. 1** and pounds on **CAL.2**. The **CAL.S** function also allows different decimal points, display rounding, mV/V range and sample rate settings between **CAL. 1** and **CAL.2**

P.SET (Preset value) - the display value will start at the value selected in the preset value function **P.SET** (this function appears after the alarm functions, see Function Table). This works in a similar manner to the Zero function except that a preset weight/pressure value can be input. If the preset operation were to cause the zero to shift beyond the **ZERO RANGE** function limits the preset will be aborted and a **ZERO RANGE Err** message will be seen.

batch (Batch) - the batch function does not affect the display value when operated. It does, however affect the retransmission and alarm functions, see the "Batch Operation" chapter for a full description.

CAL (Calibration) - when set to **CAL** the remote input can be used to perform a calibration. See "Calibration" chapter for details.

dull - display brightness control. The remote input can be used to change the display brightness. When this mode is selected the display brightness can be switched, via the remote input, between the brightness level set at the **brgt** function and the brightness level set at the **dull** function.

F.I N2 (remote input 2)

Not applicable to this instrument.

F.I N3 (remote input 3)

Not applicable to this instrument.

P.but (P button function)

If the instrument has a front panel **P** button the function of this button is programmable in the same manner as the remote input. The **P** button selection will override the selection made under the **F.I NP** function if both have the same functions selected. Upon reaching the **P.but** function the choices in the table below are available. Note: To prevent accidental operation of the **P** button in the **ERR, ZERO** or **P.SET** functions it is necessary to hold the button in for 2 seconds to perform the selected operation.

Function	Description
NONE	No function
H,	Peak memory
Lo	Valley memory
H, Lo	Toggles between peak and valley memory
ERR	Push button tare or nett or gross display function (toggles)
ZERO	Push button zero
CAL.S	Select calibration scaling (operates only whilst button pressed)
P.SET	Preset value
batch	Batch

When in **Lo,H,** or **H, Lo** the high/low values held in memory can be reset (i.e. the memory is cleared) by holding the **P** button pressed for 2 seconds. When the preset (**PSET**) is selected and the **ZERORANGE** function is used the preset will not operate if it would take the display outside the zero range limits. In this case the error message **ZERO RANGE Err** will be seen.

ACCESS (alarm relay access mode)

The access mode function **ACCESS** has one of four possible settings namely **OFF, EASY, NONE** and **ALL**. If set to **OFF** the mode function has no effect or alarm relay operation. If set to **EASY** the "easy alarm access" mode will be activated, see the explanation near the beginning of this chapter. If set to **NONE** there will be no access to any functions via **FUNC** mode, entry via **CAL** mode must be made to gain access to functions. If set to **ALL** then access to all functions can be made via **FUNC** mode i.e. there is no need for the **CAL** mode power up sequence. This function provides an alternative to using the **F.I NP** function for easy access or no access mode thereby allowing the remote input to be programmed for an alternative use.

SPAC (setpoint access)

Sets the access to the alarm relay set points. The following choices are available:

- R 1** - Allows setpoint access to alarm 1 only.
- R 1-2** - Allows access to alarms 1 and 2 only.

The remote input function (**F.I NP**) must be set to **SPAC** for this function to operate. **Note:** Only the setpoints which have been given a value will be accessible e.g. if **R 1H,** is set to **OFF** then there will be no access to the **R 1H,** function when **SPAC** is used.

LINEPTS (lineariser points) - see also "Calibration" chapter

Displays and sets the number of calibration scaling points to be used. Choices are 2, 3, 4 or 5 points.

CAL 1, CAL 2, CAL 3, CAL 4 & CAL 5 (calibration scaling points) - see "Calibration" chapter.

Displays and sets the independent calibration/scaling points of the input to the display. See "Calibration" chapter for full details of setting up.

ECAL (mV/V calibration) - see "Calibration" chapter

This alternative calibration method allows the known mV/V value of the load cell to be entered as the calibration value.

CAL OFFSE (offset calibration) - see "Calibration" chapter

Allows the instrument calibration to be offset by a single point value. This value is added or subtracted across equally the range of the instrument. Press, then release **▲** and **▼** simultaneously to enter the **CAL OFFSE** function.

SET ZERO (set zero)

Used to set the load cell system to display reading of zero. The set zero point is entered when the load cell is installed and in a no weight condition. To operate the set zero function press, then release, **▲** and **▼**

simultaneously. The zero point will be retained even if power is removed.

ZERO RANGE (zero range)

The zero range function allows a limit value to be set above which the display will not zero i.e. if a zero operation is attempted via the **0** button, remote input or set zero function when the display value is greater than the zero range setting the display will refuse to zero and give a **ZERO RANGE Err** message. For example if the zero range setting is 10 the instrument will only respond to a zero operation if the display reading at the time is between -10 and 10. If the zero range function is not required it can be set to **OFF** by pressing the **▲** and **▼** buttons simultaneously at this function. When switched off the instrument can be zeroed no matter what the display value.

Note that the instrument keeps track of the value being zeroed at each operation, when the total amount zeroed from repeated operations becomes greater than the zero range value the instrument will reject the zero operation and a **ZERO RANGE Err** message will be seen. If repeated zero operations are required the **ZERO RANGE** function should be set to **OFF** or alternatively the **TARE** operation could be considered.

CAL ZERO (calibration zero)

The calibration zero can be used to select a zero point other than the display zero as the reference for the **ZERO RANGE** function. The calibration zero function is used only with the **ZERO RANGE** function. For example if the **CAL ZERO** operation is carried out with a display reading of 500 and a **ZERO RANGE** reading of 10 the zero range function will allow the display to zero only if the current display reading is between 490 and 510.

AUTO ZERO (auto zero)

The LD4 can be set to automatically re-zero its reading if the display is within the range set by the **AUTO ZERO** function (for the set number of samples, see **A.2. Count**). For example if the auto zero is set to 10 then the instrument will re-zero itself whenever the display is within 10 units of zero for the set number of samples i.e. between -10 and 10. The auto zero can be set within the range 0 to 100 display units. Setting auto zero to **0** will disable the function and the instrument will not re-zero automatically.

The time taken to auto zero depends upon the sample rate and the sample count (**A.2. Count**) setting.

A.2. Count (auto zero sample count)

Displays and sets the number of samples to be taken for the auto zero function. For example if set to 50 then if the display is within the auto zero setting (e.g. 10) for 50 samples then the instrument will re-zero. The sample count may be set within the range of 10 to 1000.

A 1 (alarm 1 operation mode)

The alarm mode function allows the selected alarm relay to follow either the live input value (**L, UE**), the tare function (**TARE**), the peak hold function (**P.HLD**), the display hold (**d.HLD**), the peak memory (**H,)** or valley memory (**Lo**) or the display value (**d: SP**). For settings other than **d: SP** operation a remote input or **0** button must also be set to the function required. See “Batch operation” chapter for description of **batch** mode operation.

Example 1- **A1** is set to **L, UE**

With the alarm function set to **L, UE** the alarm relay operation will follow the live input based on the electrical inputs and scaling values used when the instrument is calibrated. If the value on the display has been altered from the calibration scaling values e.g. via a tare operation then the alarm operation will ignore the display changes caused by the tare operation. For example if **A 1H** is set to **100** then alarm relay 1 will activate if the display reading goes to **100** or above. If a tare operation is now carried out when the display value is **20** then the tare will cause the display value for that input to fall to zero. The alarm relay will now activate at display value of **80** or above since the live electrical input for a tared display of **80** is the same as it was for a value of **100** prior to the tare operation.

Example 2 - **A 1** is set to **TARE** and **F: NP** (remote input special function) is set to **TARE**.

Assume that **A 1H** is set to **100** and that the instrument is given a remote tare when the display reads **40**. Once the instrument is tared the display will read **0**. Alarm relay 1 is set to follow the tare value and will therefore operate when the (nett) display becomes greater than **100**.

Example 3 - **A 1** is set to **P.HLD** and **F: NP** is set to **P.HLD**

If **A 1H** is set to **100** then it will operate whenever the display shows a value over **100**. If the peak value exceeds **100** when the remote input is closed then alarm 1 will activate and will not reset until the

remote input opens **and** the display value falls below **100**.

Example 4 - **R 1** is set to **d.HLd** and **r.1 NP** is set to **d.HLd**

If **R 1Lo** is set to **5** then it will operate whenever the display shows a value below **5**. If the display hold remote input is operated at a value above **5** then the alarm will not activate whilst the remote input remains closed, no matter what the electrical input. Likewise if the remote input is operated at a value below **5** then alarm will not de activate until the remote input is opened and the display value goes above 5.

Example 5 - **R 1** is set to **H**, and **r.1 NP** is set to **H**,

If **R 1H**, is set to **50** and the peak memory value becomes greater than **50** then alarm relay 1 will be constantly activated at this point and will only become de activated when the memory is reset at a value below **50**. The memory can be reset by holding the remote input closed for 2-3 seconds. Note that in this case the alarm can be activated even if the display value is less than the alarm setting, this is because the alarm is activated by the value in peak memory rather than the display value.

Example 6 - **R 1** is set to **Lo** and **r.1 NP** is set to **Lo**

If **R 1Lo** is set to **280** and the valley memory value becomes less than **280** then alarm 1 will be constantly activated at this point and will only become de activated when the memory is reset at a value above **280**. The memory can be reset by holding the remote input closed for 2-3 seconds. Note that in this case the alarm can be activated even if the display value is greater than the alarm setting, this is because the alarm is activated by the value in valley memory rather than the display value.



Example 7- **R1** is set to **d: SP**

With the alarm function set to follow the display value the alarm relay will activate whenever the display shows an alarm condition, irrespective of any alteration to the original scaling values due to a tare, zero, peak memory etc. operation. Thus if **R 1Lo** is set to **50** and **R 1H**, is set to **100** then alarm relay 1 will activate whenever the value shown on the display falls below **50** or goes above **100**. If the **r.1 NP** function is now set to **H**, (peak memory) and the peak memory value is **100** or greater then the alarm relay will be activated whenever the remote input is used to display the **H**, value, irrespective of the live input at the time.

R2 (alarm relay 2 operation mode)

As per **R 1** function but operates relay 2.

Lo d: SP (low overrange limit value)

The display can be set to show an overrange message if the display value falls below the **Lo d: SP** setting. For example if **Lo d: SP** is set to **50** then once the display reading falls below **50** the message **-or-** or the display value (see **d: SP** function) will flash instead of the normal display units. This message can be used to alert operators to the presence of an input which is below the low limit. If this function is not required it should be set to **OFF** by pressing the  and  buttons simultaneously at this function.

H: 9H d: SP (high overrange limit value)

The display can be set to show an overrange message if the display value rises above the **H: 9H d: SP** setting. For example if **H: 9H d: SP** is set to **1000** then once the display reading rises above **1000** the message **-or-** or the display value (see **d: SP** function) will flash instead of the normal display units. This message can be used to alert operators to the presence of an input which is above the high limit. If this function is not required it should be set to **OFF**.

d: SP (display overrange warning flashing mode)

This function is used in conjunction with the **Lo** and **H: 9H d: SP** functions. The **d: SP** function can be set to **FLSH** or **-or-**. If the value set at the **Lo** or **H: 9H d: SP** function is exceeded and the **d: SP** function is set to **FLSH** then the display value will flash on for approximately one second and off for approximately one second as a warning. If the value set at the **Lo** or **H: 9H d: SP** function is exceeded and the **d: SP** function is set to **-or-** then the **-or-** message will flash on for approximately one second and off for approximately one second as a warning. The warning flashes will cease and the normal display value will be seen when the value displayed is higher than the low limit and lower than the high limit.

bRud (set baud rate)

Select from **9600**, **4800**, **2400**, **1200**, **600**, **300**, **19.2** or **38.4**.

Prty (set parity)

Select parity check to either **NONE**, **EVEN** or **Odd**.

Addr (set unit address for polled (POLL) mode (0 to 31))

Allows several units to operate on the same RS485 interface reporting on different areas etc. The LD4 **Addr** function must match the XT4-WT "Unit Address" function value for communication between the two units.

The unit address ranges from 0 to 31 (DEC) but is offset by 32 (DEC) to avoid clashing with ASCII special function characters (such as <STX> and <CR>). Therefore 32 (DEC) or 20 (HEX) is address 0, 42 (DEC) or 2A (HEX) addresses unit 10.

SERIAL TYPE (serial output)

Options are: **NONE** (no output), **R232** (RS232), **R485** (RS485) or **I 20** (serial current loop). For communication with the XT4-WT this function must be set to **R485**.

4.1 Error Messages

CAL ERR - This indicates that one of the calibration points has caused an overrange error in the analog to digital converter. Change the mV/V (**FNGE** function) setting to a higher value and try calibration again.

SPAN ERR - This indicates that the calibration points entered were too close together. Either calibrate again with the points further apart or change the mV/V setting to make the instrument more sensitive. The calibration points need to be at least 10% of full scale apart.

ADC GAIN ERR - This indicates that when an **ECAL/ESCL** method of calibration has been used the mV/V figure entered at the **ECAL** function is greater than the mV/V range entered at the **FNGE** function. The **FNGE** function should be set to be equal the **ECAL** value or to the next available value higher than the **ECAL** value.

ZERO FNGE ERR - This indicates that an attempt to zero or preset a value on the display has failed due to the **ZERO FNGE** function value being exceeded. Check the **ZERO FNGE** function setting, if this is set at the required figure and the display value seems to be within the zero range limits then it could be that previous preset or zero operations has caused the limit to be exceeded.

" - - - - " - This display indicates that the actual mV input is higher than the value set at the **FNGE** function. Check the **FNGE** function setting and if this is OK then check the actual mV input from the cell. Note that the **FNGE** setting is nominal and so the " - - - - " message may occur just before or just after the limit is reached. This message could also indicate an open circuit in the wiring or incorrect wiring from the XT4 to the load cell.

" -or - " - This display indicates an overrange reading. This could be due to the instrument not being able to display the number because it is too large e.g. above 9999 on a 4 digit display. Alternatively it could mean that the **Lo** or **Hi SH d: SP** limit value has been exceeded and the instrument is showing a warning message.

Display value flashes on and off - This means that the **Lo** or **Hi SH d: SP** limit value has been exceeded and the instrument is showing a warning message.

NO ACCESS - This display mean that function access has been denied. This will be due to either one of the remote input functions (**F:1 NP**, **F:1 N2** or **F:1 N3**) being set to **No.Ac** or that the **ACCESS** function being set to **NONE**. To override the remote input functions and gain access you can either place a short circuit between the appropriate remote input and ground or power up the instrument in **CAL** mode (see "Explanation of functions" chapter). To override the **ACCESS** function you must power up in **CAL** mode.

NO SPAC - This display mean that function access has been denied. This will be due to either one of the remote input functions (**F:1 NP**, **F:1 N2** or **F:1 N3**) being set to **SP.Ac** or the **ACCESS** function has being set to **ERSY** and all alarm setpoints have been set to **OFF**. To override the remote input functions and gain access you can either place a short circuit between the appropriate remote input and ground or power up the instrument in **CAL** mode (see "Explanation of functions" chapter). To override the **ACCESS** function you must power up in **CAL** mode.

Returning to normal measure mode

When the calibration has been completed it is advisable to return the instrument to the normal mode (where calibration functions cannot be tampered with). To return to normal mode, turn off power to the instrument, wait a few seconds and then restore power.

5 Function Table

Initial display	Meaning of display	Next display	Default Setting	Record Your Settings
A 1Lo	Alarm relay 1 low setpoint value	Setpoint value or OFF	OFF	
A 1Hi	Alarm relay 1 high setpoint value	Setpoint value or OFF	OFF	
A 2Lo	Alarm relay 2 low setpoint value	Setpoint value or OFF	OFF	
A 2Hi	Alarm relay 2 high setpoint value	Setpoint value or OFF	OFF	
A 1HY	Alarm relay 1 hysteresis	Hysteresis value in measured units	1	
A 2HY	Alarm relay 2 hysteresis	Hysteresis value in measured units	1	
A 1tE	Alarm relay 1 trip time	No of seconds before relay trips	0	
A 2tE	Alarm relay 2 trip time	No of seconds before relay trips	0	
A 1rE	Alarm relay 1 reset time	Reset time in seconds	0	
A 2rE	Alarm relay 2 reset time	Reset time in seconds	0	
A 1n.o or A 1n.c	Alarm relay 1 action N/O or N/C	A 1n.o or A 1n.c	A 1n.o	
A 2n.o or A 2n.c	Alarm relay 2 action N/O or N/C	A 2n.o or A 2n.c	A 2n.o	
A 2.SP or A 2.t1	Setpoint or trailing alarm operation for relay 2	A 2.SP or A 2.t1	A 2.SP	
br9E	Display brightness	1 to 15	15	
duLL	Remote display brightness switching	0 to 15	1	
A 1FFEE	Alarm 1 free fall value	Value in memory	0	See following table
A 2FFEE	Alarm 2 free fall value	Value in memory	0	See following table
P.5E	Preset value	Value in memory	0	
CL.no	Cell calibration number selection	CAL. 1 or CAL. 2	CAL 1	
Function below are accessible only via CAL mode				
drnd	Display rounding selects resolution	Value in memory	1	
dCPE	Display decimal point	Decimal point position (e.g. 0.0 , 10.02 or 0.003)	0	
FLtr	Digital filter range 0 to 8	0 to 8 (8 =most filtering)	3	
rAEE	Sample rate (samples per second)	1 , 2 or 5	1	
rA9E	Full scale mV/V range	2.0 , 4.0 , 8.0 or 16.0	2.0	
r.1 NP	Remote input 1	NONE , P.HLD , d.HLD , H , Lo , H , Lo , tAFE , 2EFO , SP.Ac , No.Ac , CAL.S , P.5E , tE , btch , CAL or duLL	NONE	
r.1 R2		Not applicable to this instrument		
r.1 R3		Not applicable to this instrument		
P.but	 Button function	NONE , H , Lo , H , Lo , tAFE , 2EFO , CAL.S , P.5E or btch	NONE	
ACCS	Access mode	OFF , EASY , NONE or ALL	OFF	
SPAC	Setpoint access	A 1 or A 1-2	A 1	

Initial display	Meaning of display	Next display	Default Setting	Record Your Settings
Lin Pts	Lineariser points	2, 3, 4 or 5	2	
CAL 1	First scaling point	Live reading	n/a	
CAL 2	Second scaling point	Live reading	n/a	
ECAL	Calibration by entering mV/V & scale values	See calibration chapter	n/a	
CAL OFFSt	Offset to calibration	Live reading	n/a	
SEt ZER0	Set zero	See calibration chapter	n/a	
ZER0 RnGE	Zero range limit	Limit value or OFF	1000	
CAL ZER0	Zero point calibration	0	n/a	
Aut0 ZER0	Auto zero range	0 to 100	0	
A.Z. Cnt	Auto zero samples	10 to 1000	10	
A 1	Alarm mode for relay 1	L, uE, tARFE, bEtch, P.HLd, d.HLd, Hi, Lo or d! SP	L, uE	
A 2	Alarm mode for relay 2	L, uE, tARFE, bEtch, P.HLd, d.HLd, Hi, Lo or d! SP	L, uE	
Lo d! SP	Display low overrange	Limit value or OFF	OFF	
Hi 9H d! SP	Display high overrange	Limit value or OFF	OFF	
d! SP	Overrange display warning flashing mode	FLSH or -or-	FLSH	
bAUD RATE	Baud rate	300, 600, 1200, 2400, 4800, 9600, 19.2 or 38.4	9600	
Prty	Parity select	NONE, EVEN or Odd	NONE	
Addr	Set unit address for poll mode	0 to 31	0	
SEr. tYPE	Serial output type	NONE, F232, F485 or 120	F485	

6 Batch operation

The remote input **F.I. NP** or the **P** button function **P.but** may be programmed to operate in batch (**btch**) mode. Operation of any of these inputs in batch mode will have no effect on the displayed value (i.e. the total load or weight is always visible) but can be made to affect the method in which the setpoint alarm relays and retransmission options operate.

Alarm operation in batch mode.

In addition to setting the required remote input or **P** button function to **btch** the alarm mode function for the required alarm operation mode must also be set to **btch**. The alarm operation mode functions are **A1** for alarm 1, **A2** for alarm 2 etc.

When in batch mode the selected alarm may be set to operate at a given batch figure i.e. **A1Lo** or **A1H**, can be allocated batch values.

Example

Assume that the panel meter is scaled to read in kilograms up to a maximum of 1000kg. **F.I. NP** is set to **btch** and **A1** is also set to **btch**. **A1H** is set to **100**, **A1Lo** is set to **OFF** and **A1HY** is set to **0**. If the display reading is **300** when the remote input is operated then the display will not alter but alarm 1 relay will now activate when the display reading increases by the batch value of **100** i.e. at a value of **400** or above.

The effect on alarm settings for the same example is shown in the table below.

Alarm Settings with A1HY=0	Alarm deactivates	Alarm activates
A1Lo = OFF, A1H = 100	At values below 400	At values above 400 i.e. 300 + the batch value
A1Lo = OFF, A1H = - 100	At values below 200	At values above 200
A1Lo = 100, A1H = OFF	At values above 400	At values below 400
A1Lo = - 100, A1H = OFF	At values above 200	At values below 200
A1Lo = 50, A1H = 100	At values between 350 & 400	At values below 300 or above 400

The effect of a hysteresis setting (setting **A1HY** to **10** in this example) is shown in the table below.

Alarm Settings with A1HY= 10	Alarm deactivates	Alarm activates
A1Lo = OFF, A1H = 100	At values below 390	At values above 400
A1Lo = OFF, A1H = - 100	At values below 190	At values above 200
A1Lo = 100, A1H = OFF	At values above 410	At values below 400
A1Lo = - 100, A1H = OFF	At values above 210	At values below 200

Example

Assume that **AL1** is set to **-25.0** and that the instrument is given a remote batch input when the display reads **200.0** i.e. the alarm relay is activated at this stage. The display does not alter when a batch input is applied but alarm 1 will not reset until the display goes below **175.0** (**200** minus **25.0**). i.e. once the batch input is applied the display value must decrease by the alarm value before the alarm will reset.

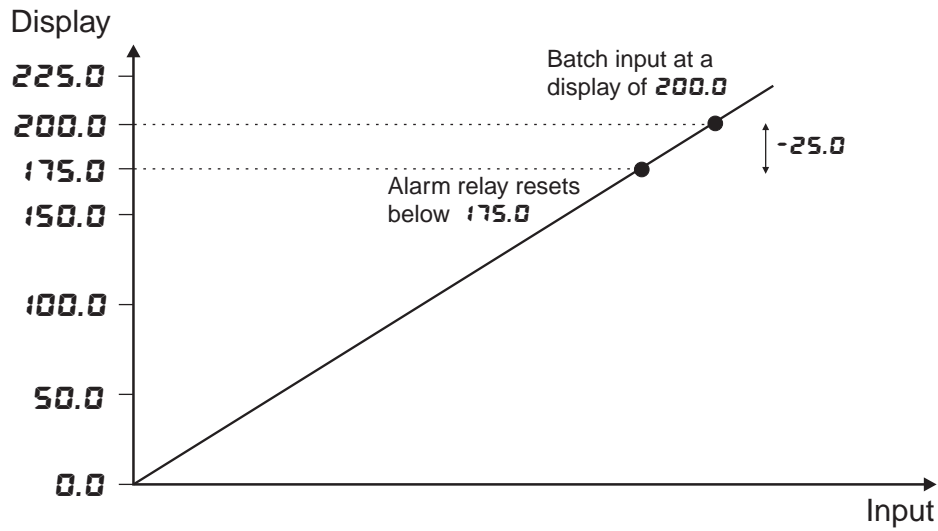

A practical application for this example would be in filling containers from a hopper. The display would continue to show the weight remaining in the hopper and the alarm relay could be set to open 25.0 units (e.g. kilograms) after the batch input is operated. In this example the alarm relay is wired in series with a pump relay, the alarm relay is used to control the pump relay and halt the flow of product once the batch weight of 25kg has been removed from the hopper. If other alarm relays are fitted they could be set for non batch operation and used to give an alarm to warn of the hopper emptying and/or over filling.

7 Calibration

To enter the **CAL** (calibration) mode a follow the method described on page 8.

The calibration procedures allow four different methods of calibration scaling to suit various applications.

Method 1 - two, three, four or five calibration points are independently set from “live” inputs. The ability to set each point individually is useful where the calibration is being carried out on site and delays are experienced during the calibration procedure (e.g. filling tanks etc.).

If two points are used the display will be linear. If more than two points are used the display can be made to follow a linearisation curve. The number of points to be used is set at the **LCALPTS** function.

Method 2 - allows entry of the mV/V figure of the load cell being used together with a scaling value i.e. no live input is required to obtain the scaling points. Note that this method is only applicable if two linearisation points are set.

Method 3 - allows a single point offset to be introduced.

Method 4 - allows a simple pushbutton calibration from a live input. This method is particularly suited to item counting applications. Note that this method is only applicable if two linearisation points are set.

Calibration - method 1, calibration by entering in known values

Method 1 uses two, three, four or five different live input values to calibrate the instrument.

1. Step through the functions until the display indicates **LCALPTS** and use the **▲** or **▼** pushbutton to select the number of calibration scaling points required.
2. Step through the functions until the display indicates **CAL 1**. Now press, then release, the **▲** and **▼** buttons simultaneously to enter the calibration functions. The display will now indicate **CAL 1** (1st calibration point) followed by a “live” reading. Apply a known input to the instrument of nominally 0% (this value is not critical and may be anywhere within the measuring range of the instrument). For example you could arrange that the load or pressure is zero at this time. When the live reading has stabilised press the **■** button.
3. The display will indicate **SCL 1** (scale 1) followed by the scale value in memory. Now use the **▲** or **▼** button to obtain the required scale value.
4. Press the **■** button, the display will now indicate **CAL End** (indicating that calibration of the first point is complete).
5. The display will now indicate **CAL 2** (2nd calibration point). If you do not wish to enter the second point at this stage then press and release the **■** button until the **FUNC End** message is seen. If you wish to enter the second point at this stage press the **▲** and **▼** buttons simultaneously.
6. The display will now indicate **CAL 2** (2nd calibration point) followed by a “live” reading. Apply an input greater than that used for **CAL 1** (again this value is not critical, but there needs to be a change of at least 10% of the capacity of the load cell between points).
7. When the reading has stabilised, press the **■** button, the display will now read **SCL 2** (scale 2) followed by the second scale value in memory. Use the **▲** or **▼** button to obtain the required scale value. Press the **■** button, the display will now read **CAL End** (indicating that calibration of the second point is complete).
8. Repeat the process for the remaining calibration points.

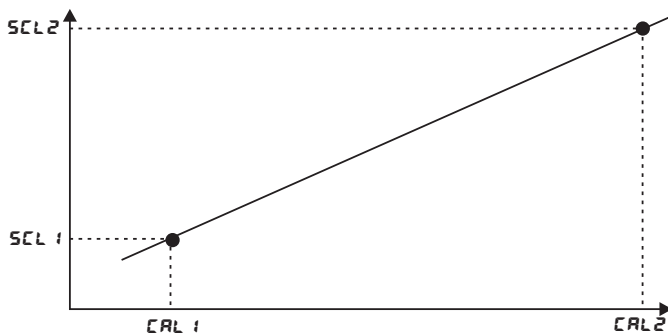

Two scaling points - display is linear

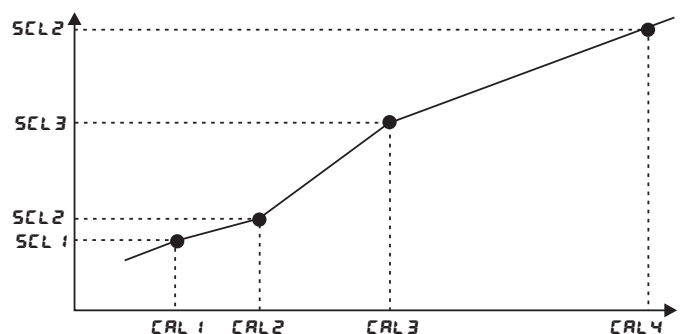

More than two scaling points - linearised display

Example - Scaling using two points

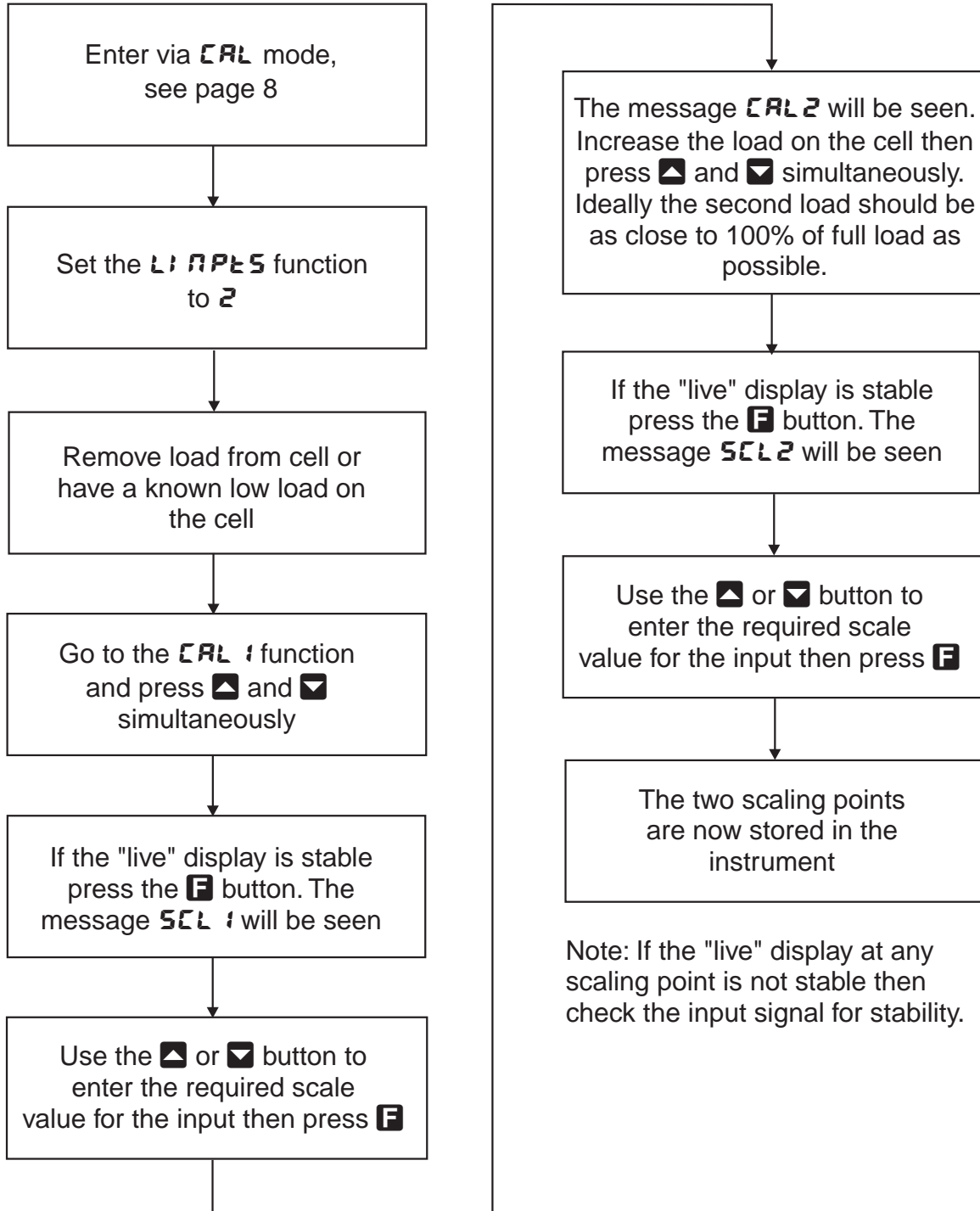

Calibration - method 2, calibration by entering the mV/V value

Note: this method can only be used if the **L: RPTS** function is set to **2**.

This alternative calibration method allows the known mV/V value of the load cell to be entered as the calibration value. The value is entered to 3 decimal places, any number from 9.999 to -1.999 mV/V can be input. If the required value is outside this range then use a convenient available value and alter the **ESCL** value to compensate.

1. In calibration mode step through the functions until the **ECAL** display is seen.
2. Press the **▲** and **▼** buttons simultaneously to get a display of the current mV/V setting. Use **▲** or **▼** to alter this value to the mV/V output of the cell being used.
3. Press and release the **F** button, the display will now show **ESCL** followed by the current scale value.
4. Use **▲** or **▼** to alter this value if required (this value is the reading required at the maximum rated

load for the cell e.g. for a 100kg load cell required to display directly in kg set the **ESCL** value to **100** (or **100.0** etc.) depending on the decimal point setting).

5. Press then release the **F** button the display will show **ECAL End** and the instrument moves on to the next function (**CAL OFFSt**).

6. Once the **ECAL** value has been entered you must operate the **SEt ZER0** function described below or use the **P** button or remote input **ZER0** function to zero the display at no load/pressure. This zeroing process will remove the effects of any no load offset outputs present at the sensor.

If using the two point calibration method (method 1), as previously described, the mV/V value is automatically calculated and may be viewed at the **ECAL** function. The **ECAL** and **ESCL** values may be recorded and re-entered to re-scale the instrument to the same load cell at a later date.

SEt ZER0 (set zero)

Used to set the load cell system to display reading zero. The set zero point is entered when the load cell is installed and in a no weight condition.

In calibration mode step through the functions until the **SEt ZER0** display is seen. Press the **▲** and **▼** buttons simultaneously to get a "live" display. Pressing and releasing the **F** button gives a **ZER0 End** display.

Calibration - method 3, Offset Calibration

It is sometimes necessary to make a single point adjustment to the calibration, it may be done using this function. Note the value set in this function will add or subtract the value equally across the measurement range of the instrument.

Enter the calibration mode as described above, but do not enter **CAL 1** or **CAL 2** setup functions. Step through the functions until the display indicates **OFFSt**, Now press the **▲** and **▼** buttons simultaneously to enter the offset mode. The display will now indicate **OFFSt** (offset) followed by the "live" reading. *Apply a known input to the instrument. When the reading has stabilised press the **F** button. The display will indicate **SCALE** (scale) followed by the value set in memory. Now press the **▲** or **▼** button to obtain the required display value for this input. Press the **F** button the display will now indicate **OFFSt End** (indicating that the offset calibration is complete).

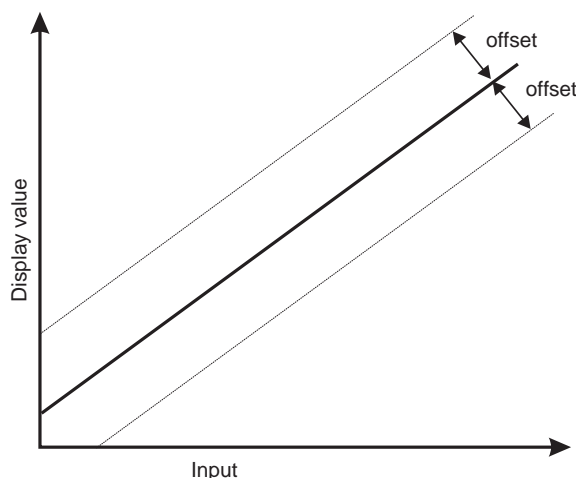

Calibration - method 4, Remote Input Calibration

Note: this method can only be used if the **LI, n PLS** function is set to **2**.

The remote input calibration method allows simple, live input, calibration suitable for situations requiring frequent calibration such as in item counting by weight applications. In this method of calibration a remote input function (e.g. **F.I NP**) is assigned to **CAL**, closure of the remote input then initiates the calibration process. The procedure is as follows:

1. Assign a remote input (e.g. via **F.I NP** function) to **CAL**.
2. Assign a different remote input or the **P** button to **ZER0** and zero the display when it is in a no load condition.
3. Place a weight (or known number of items) on the weighing platform then operate the **CAL** remote input i.e. close the switch.
4. The message **SCALE** will appear on the display followed by the previous scale value in memory. Use the **▲** or **▼** button to alter this reading to the value required for this load.
5. Press, then release, the **F** button, the message **CAL End** will be seen and the instrument will return

to normal measure mode.

Note that the **P** button may be used to abort the calibration process once beyond step 3.

Returning to the normal measure mode

When the calibration procedure has been completed it is advisable to return the instrument to the normal mode (where calibration functions cannot be tampered with). To return to the normal mode, turn off power to the instrument, wait a few seconds and then restore power.

Note:

* “Apply a known input” refers to either a simulated or real input. Since the LD4 is intended for use with various 4 or 6 arm strain gauge transducers, this input may take the form of a weight (load cell applications), applied force (torque transducers), an air or hydraulic pressure input (pressure transducers), or a suitable electronic simulator etc.

8 Specifications

8.1 Technical Specifications

See XT4-WT manual for further specifications.

Input types:	RS485 serial comms. from XT4-WT
Baud rate:	300, 600, 1200, 2400, 4800, 9600, or 19.2 programmable
Microprocessor:	MC68HC11 CMOS
Ambient Temperature:	-10 to 60°C
Humidity:	5 to 95% non condensing
Power Supply:	AC 240V, 110V 50/60Hz or 15 to 24VDC non isolated DC 12 to 48VDC isolated Supply type is factory configured
Outputs:	2 x Setpoint relays, form A, rated 5A at 240VAC
Power Consumption:	AC supply 4 VA max, DC supply, consult supplier (depends on display type & options)

8.2 Physical characteristics

Model LD4-RS-X-574	Display 57mm 4 digit LED Case size (mm) = 255 x 145 x 125 Weight: = 1.3 kgs Mounting hole locations (mm) = 180(w) x 55(h)
--------------------	--

9 Guarantee and Service

The product supplied with this manual is guaranteed against faulty workmanship for a period of 2 years from the date of dispatch.

Our obligation assumed under this guarantee is limited to the replacement of parts which, by our examination, are proved to be defective and have not been misused, carelessly handled, defaced or damaged due to incorrect installation. This guarantee is VOID where the unit has been opened, tampered with or if repairs have been made or attempted by anyone except an authorised representative of the manufacturing company.

Products for attention under guarantee (unless otherwise agreed) **must be returned to the manufacturer freight paid** and, if accepted for free repair, will be returned to the customers address in Australia free of charge.

When returning the product for service or repair a full description of the fault and the mode of operation used when the product failed must be given.

In any event the manufacturer has no other obligation or liability beyond replacement or repair of this product.

Modifications may be made to any existing or future models of the unit as it may deem necessary without incurring any obligation to incorporate such modifications in units previously sold or to which this guarantee may relate.

**This document is the property of
the instrument manufacturer
and may not be reproduced in whole or part without the
written consent of the manufacturer.**

This product is designed and manufactured in Australia.