

TH3-OR calibration procedure

Redox (ORP) electrodes

View of transmitter and terminals
(with screw-on cover removed)

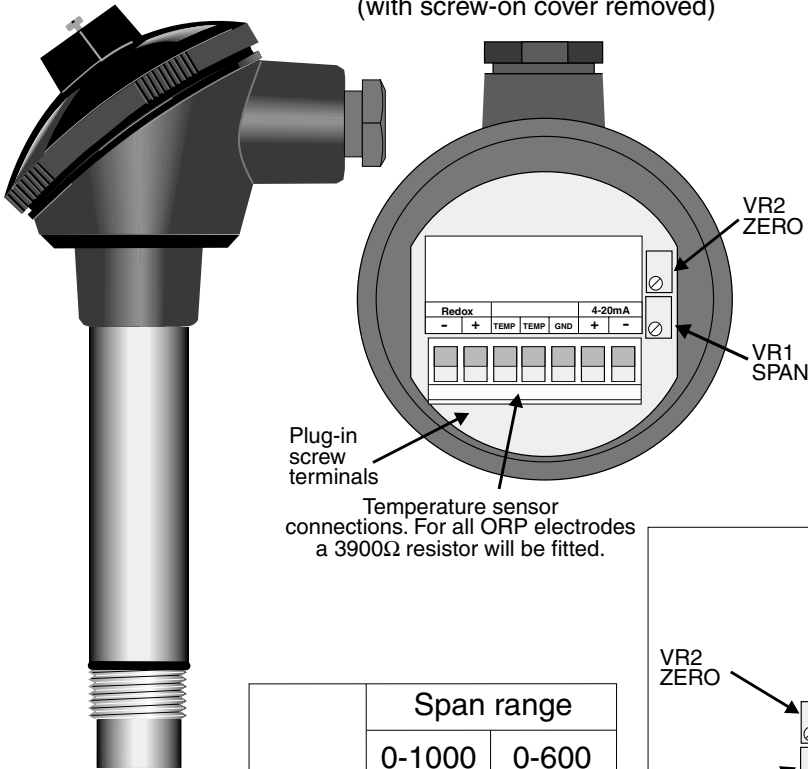

Temperature sensor connections. For all ORP electrodes a 3900Ω resistor will be fitted.

mV	Span range	
	0-1000	0-600
	mA	mA
0	4.00	4.00
100	5.60	6.67
200	7.20	9.33
300	8.80	12.00
400	10.40	14.67
500	12.00	17.34
600	13.60	20.00
700	15.20	20.00
800	16.80	20.00
900	18.40	20.00
1000	20.00	20.00

Transmitter specifications

Inputs: ORP (Redox) electrode
3900Ω resistor

Output: 2 wire 4-20mA loop powered
0mV not zero adjustable
Span adjustable 600-1000mV

Accuracy: Better than 0.25% of full scale when calibrated

Loop isolation: 100V DC or RMS

Protection: Reverse polarity protected

Loop supply: 15 to 36VDC

Ambient temperature: 0 to 60°C

Humidity: 5-95% non-condensing

Calibration procedure

The procedure for trimming the 4-20mA output is:

1. Place a mA meter in series with the 4-20mA loop.
2. Place a short circuit input (0mV) across the electrode input terminals.
3. Adjust the ZERO potentiometer VR2 until the reading on the mA meter is 4 mA.
4. Place the electrode in a know ORP standard solution..
5. Adjust the SPAN potentiometer VR1 until the reading on the mA meter is the mA output required (see table for OPR zero and span outputs).
6. Repeat steps 2 to 5 until no further adjustment is needed i.e. until the mA outputs settle on the correct high and low values without any need for adjustment.

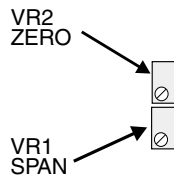

Wiring examples

