

Large Digit Display – 100mm digit height LD-SS Synchronous Serial Interface (SSI)

The 100mm digit height LD-SSI displays are ideal for applications where value from SSI input needs to be visible from a distance (rated for up to 50 metres). Inputs from SSI binary or SSI gray code at up to 31 bits can be accepted with the LD-SS providing the SSI clock signals. The display can be scaled to display in engineering units such as Litres, mm etc.

Display examples



4 digit 100mm Red LED



4 digit 100mm Yellow Flip Digit (Stainless Steel case)



5 digit 100mm Yellow Flip Digit



6 digit 100mm Red LED

Features

- Visible from 50 metres
- 4 digit 100mm Red LED
- 6 digit 100mm Red LED
- 4 digit 100mm Yellow Electromagnetic
- 5 digit 100mm Yellow Electromagnetic
- 6 digit 100mm Yellow Electromagnetic
- Gray code or binary SSI input (up to 31 bits)
- Versatile scaling methods
- 90kHz or 600kHz clock frequency selectable
- IP65 rated wall mount enclosure, powder coated steel standard, stainless steel optional
- 2 configurable setpoint relays standard rated at 240VAC, 5A into a resistive load, form C
- Pushbutton setup and scaling
- Two sets of scaling can be entered and these can be selected for the display via one of remote inputs e.g. display could be scaled in both % and litres.
- Remote inputs can be configured to one of a wide range of functions including zero, display hold, scaling switching, peak hold, etc.
- Programmable digital filter
- The auto-brightness feature for LED displays varies the display brightness to suit the ambient light
- 2 year guarantee
- See separate brochures for 38, 45, 57mm and 200mm display models

Quality
Endorsed
Company



LDSS100-3.3-0

AMALGAMATED INSTRUMENT CO PTY LTD

ACN: 001 589 439

Unit 5, 28 Leighton Place Hornsby
NSW 2077 Australia

Telephone: +61 2 9476 2244
Facsimile: +61 2 9476 2902

e-mail: sales@aicpl.com.au
Internet: www.aicpl.com.au

Specifications

Input:	SSI - Synchronous Serial Interface (binary or Gray Code coded SSI input, programmable) up to 31 bits
Clock rate	90kHz or 600kHz selectable
Sensor supply	24VDC (50mA max.)
Microprocessor	MC68HC11 CMOS
Ambient temp	-10°C to 60°C
Humidity	5% to 95%
Display types:	100mm 4 digit red LED 100mm 6 digit red LED 100mm 4 digit yellow electromagnetic (flip digit) 100mm 5 digit yellow electromagnetic (flip digit) 100mm 6 digit yellow electromagnetic (flip digit) See separate brochures for other display sizes
Power supply:	See order code table (type is factory configured)
Power usage:	AC supply 15VA max, DC supply typically 300mA at 24VDC for LED displays (1A peak), typically 1A for electromagnetic displays (4A peak) (plus current for sensor if on board supply is used)
Outputs (standard):	2 x relays, form C, rated at 240VAC, 5A resistive
Outputs (optional):	See order code table
Relay action:	Programmable N.O. or N.C.
Environmental rating:	IP65
Weight:	4 digit displays 10.5kg, 5 digit displays 12kg, 6 digit displays 13.5kg
Dimensions:	4 digit displays 450 x 250 x 155mm 5 digit displays 520 x 250 x 155mm 6 digit displays 650 x 250 x 155mm

Optional shrouds

Shroud kits for 100mm displays consist of 2 side panels, a top plate (length is model dependant) and fixing hardware. The overhang of the shroud is 90mm for all models. The shrouds are of powder coated zinc coated steel to match the metal enclosures.

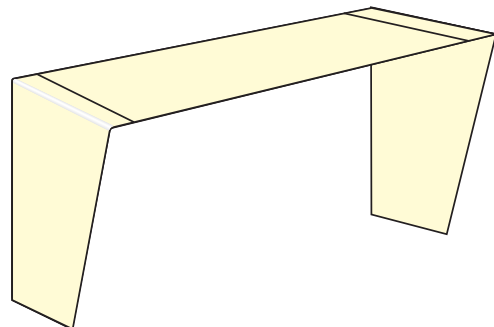
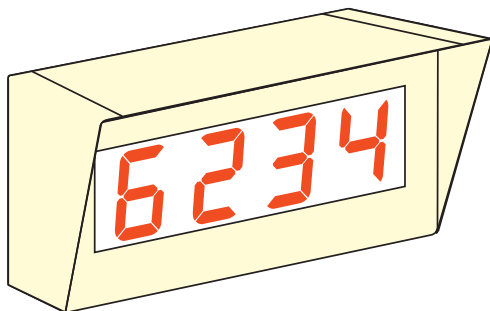

LDSS100-3.3-0

AMALGAMATED INSTRUMENT CO PTY LTD

ACN: 001 589 439

Unit 5, 28 Leighton Place Hornsby
NSW 2077 Australia

Telephone: +61 2 9476 2244
Facsimile: +61 2 9476 2902

e-mail: sales@aicpl.com.au
Internet: www.aicpl.com.au

LD-SS order codes for 100mm displays

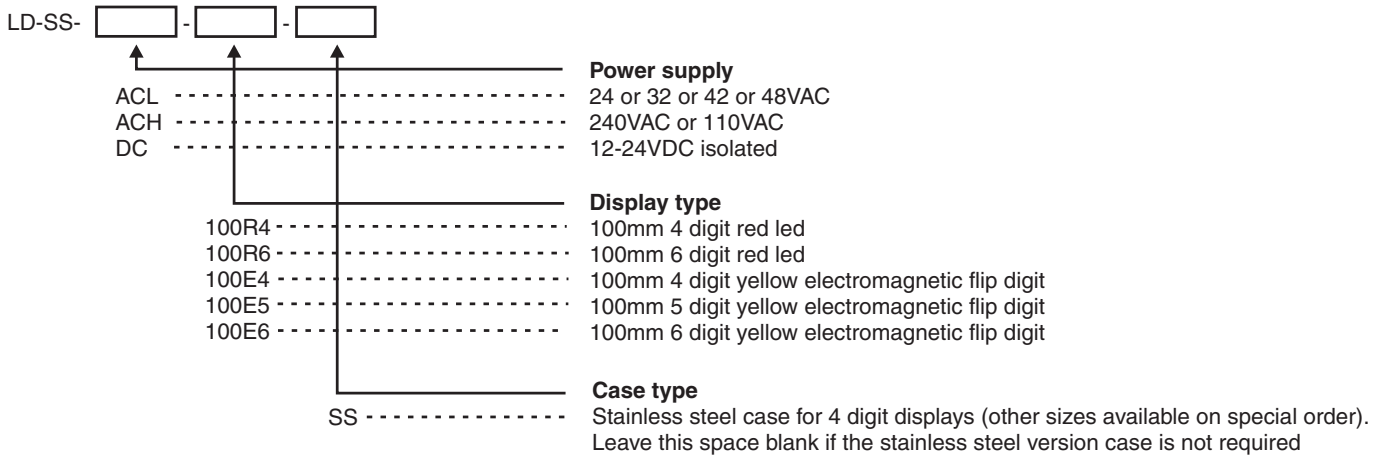

Mounting brackets

The 100mm models are shipped with 4 metal brackets and mounting hardware.

The diagrams illustrate vertical and horizontal installation of these brackets. If mounting without the brackets, then the 9mm diameter case holes provided for the brackets can be used as alternative mounting holes. If the brackets are not used in mounting, then these holes should be sealed against dust and water.

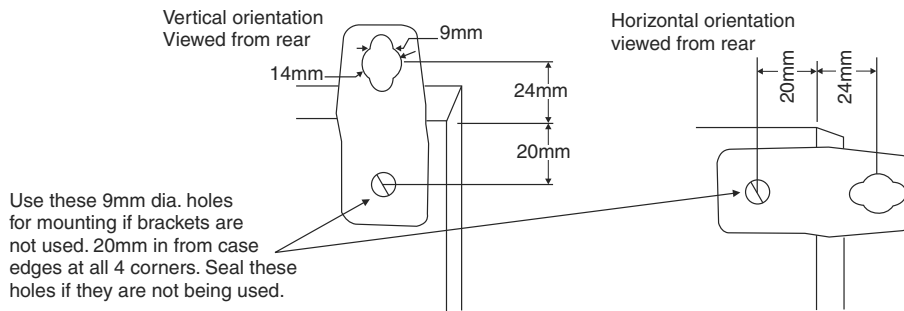

Applications/input types available with large digit display models

- Analog input, process transmitters etc. $\pm 20\text{mA}$, 4-20mA or $\pm 2.5\text{VDC}$, $\pm 25\text{VDC}$, slidewire
- Pulse input, rate, total, count, grand total (encoders, switches, proximity sensors etc.)
- Temperature - RTD, thermocouple, 4-20mA
- Weighing - 4 or 6 wire mV/V output loadcells
- Pressure measurement - 4 or 6 wire mV/V pressure sensors or 4-20mA analog transducers
- Liquid level measurement - 4 or 6 wire mV/V pressure sensors or 4-20mA analog transducers
- Serial input - RS232, RS485, Serial current loop for slave displays etc.
- Synchronous Serial Interface (SSI) for high accuracy position etc. measurement
- Binary, BCD or Gray Code input
- Real Time clock with alarms
- Multifunction timer - elapsed time, stopwatch, run time etc.

LDSS100-3.3-0

AMALGAMATED INSTRUMENT CO PTY LTD

ACN: 001 589 439

Unit 5, 28 Leighton Place Hornsby
NSW 2077 Australia

Telephone: +61 2 9476 2244
Facsimile: +61 2 9476 2902

e-mail: sales@aicpl.com.au
Internet: www.aicpl.com.au