

TP427 IP65 Enclosure - Wall or Panel Mount

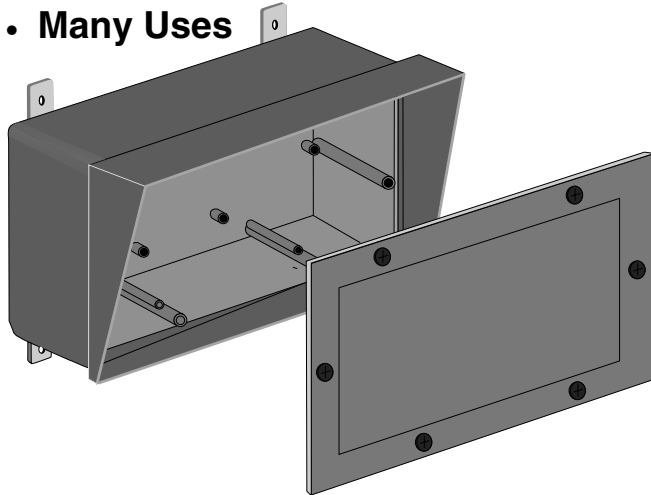

- IP65 Rated
- UV Stabilised
- Wall or Panel Mount
- Fast Delivery (Usually Ex-Stock)
- Many Uses

AIC manufactures a weatherproof enclosure suitable for wall or panel mounting. It has mounting pillars incorporated in the moulding in the base and immediately under the front panel for securing boards, plates etc. This makes the enclosure very suitable for housing digital displays, lamps, pushbutton switches etc.



It comes complete with wall mounting brackets and screws, a front plate sealing gasket, the front plate and its sealing screws. The 4 mounting holes are located 180mm(w) x 155mm(h).

The case material is Black ASA. Front panels are available in Black ASA, Clear Polycarbonate, Red translucent Lexan or Green translucent Lexan. Case components are available separately.

An optional kit is available for panel mounting the enclosure.

The enclosure is also available without the hood. This allows panel mounting with a projection of only 12 mm.

Order Codes:

- | | |
|-----------------|---|
| TP427-BOX-B-KIT | TP427 enclosure base - black ASA, tabs & screws |
| TP427-BOX-B-LF | TP427 enclosure base without hood |
| TP427-FRONT-B | Front panel - black ASA with screws |
| TP427-FRONT-C | Front panel - clear polycarbonate with screws |
| TP427-FRONT-G | Front panel - translucent green Lexan with screws |
| TP427-FRONT-R | Front panel - translucent red Lexan with screws |
| TP427-SEAL-B | Seal - black |
| TP427-SEAL-W | Seal - white |

LD-MTG-PM -KIT Panel mounting kit

